

INVERTEK[®]

U Series

Pure Sine Wave Inverter with UPS Mode



USER MANUAL



Content

SAFETY INSTRUCTIONS	1
A. GENERAL SAFETY PRECAUTIONS	1
B. EXPLOSIVE GAS PRECAUTIONS	1
C. PRECAUTIONS WHEN WORKING WITH BATTERIES.....	1
FEATURES	2
D. INTRODUCTION.....	3
E. NAME AND MAIN FUNCTION	4
F. REAR VIEW.....	5
G. CONNECTION AND TESTING.	6
H. INSTALLATION.....	7
GROUND FAULT CIRCUIT INTERRUPTERS (GFCI'S)	9
I. OPERATION:	10
J. OPERATING LIMITS	12
K. TROUBLE SHOOTING	13
L. MAINTENANCE	15
APPENDIX A	16
A-1. DIP SWITCH	16
A-2. CIRCUIT CONFIGURATION AND CODE EXPLANATION	17
SPECIFICATION	19

Safety Instructions



WARNING!

Before installing and using your Inverter, read the safety instructions.

A. General Safety Precautions

- A-1. Do not expose the Inverter to rain, snow, spray, bilge or dust. To Reduce risk of hazard, do not cover or obstruct the ventilation openings. Do not install the Inverter in a zero-clearance compartment. Overheating may result.
- A-2. To avoids a risk of fire and electronic shock. Make sure that existing wiring is in good electrical condition; and that wire size is not undersized. Do not operate the Inverter with damaged or substandard wiring.

B. Explosive Gas Precautions

This equipment contains components, which can produce arcs or sparks. To Prevent fire or explosion do not install in compartments containing batteries or Flammable materials or in locations which require ignition protected equipment. This includes any space containing gasoline-powered machinery, fuel tanks, or joints, fittings, or other connection between components of the fuel system.

C. Precautions When Working With Batteries

If battery acid contacts skin or clothing, wash immediately with soap and water. If acid enters eye, immediately flood eye with running cold water for at least 20 minutes and get medical attention immediately.

- C-1. NEVER smokes or allow a spark or flame in vicinity of battery or engine.

C-2. Do not drop a metal tool on the battery. The resulting spark or short-circuit on the battery or other electrical part may cause an explosion.

C-3. Remove personal metal items such as rings, bracelets, necklaces, and watches when working with a lead-acid battery. A lead-acid battery produces a short-circuit current high enough to weld a ring or the like to metal, Causing a severe burn.

FEATURES

- Microprocessor based design with absolutely accurate and stable frequency.
- Switch selectable 50 or 60 Hz output for all models.
- Very low harmonic distortion, THD<3%.
- Standard inputs 12V & 24V
- Output 230V
- Remote control unit (optional extra)
- Power Saving
- Panel indicators for battery voltage & load level (%)
- Compact and light weight, yet rugged and vehicle rated, 83-90% efficient
- Capable of driving highly reactive loads such as electric tools and appliances
- Built-in fast acting AC synchronized transfer switch (<10msec)

D. Introduction:

The power inverter series are the member of the most advanced line of mobile AC power systems available. To get the most out of the power inverter, it must be installed and used properly. Please read the instructions in this manual before installing and using this model.

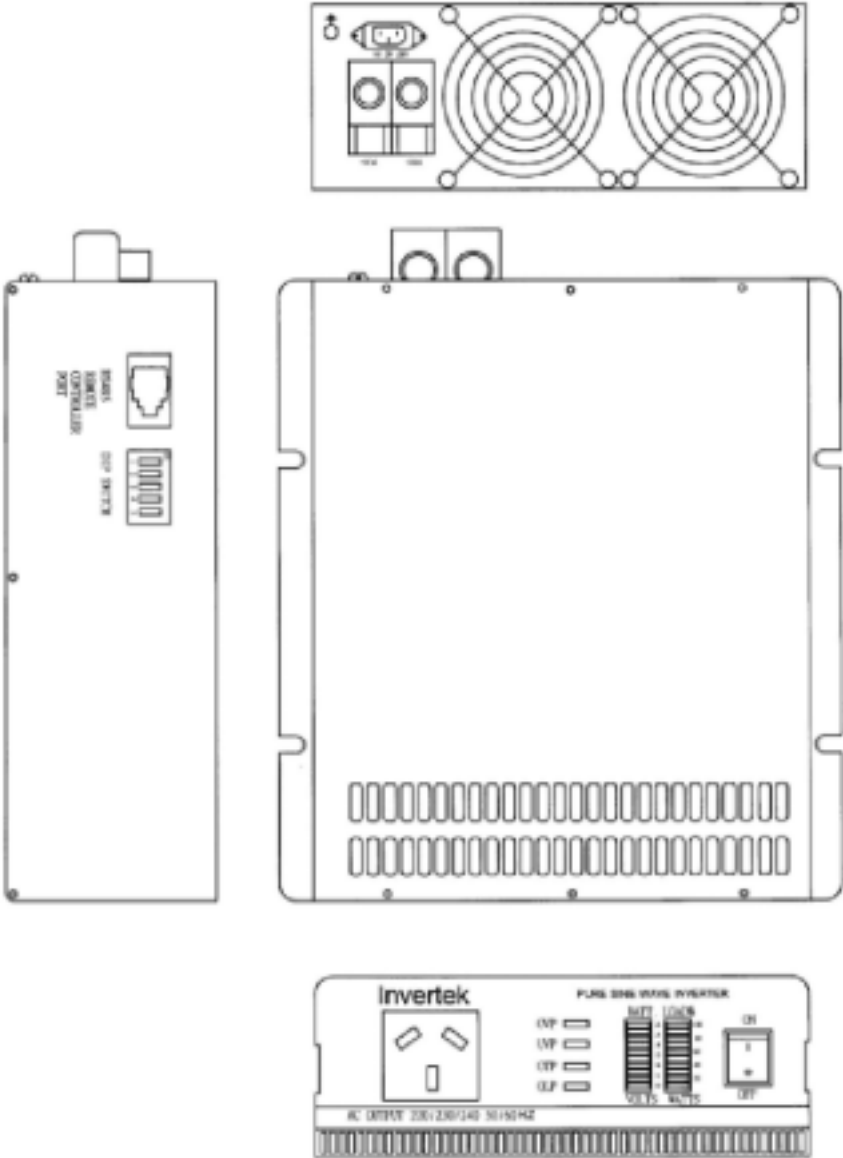

E. Name and main function :

E-1. Front view :

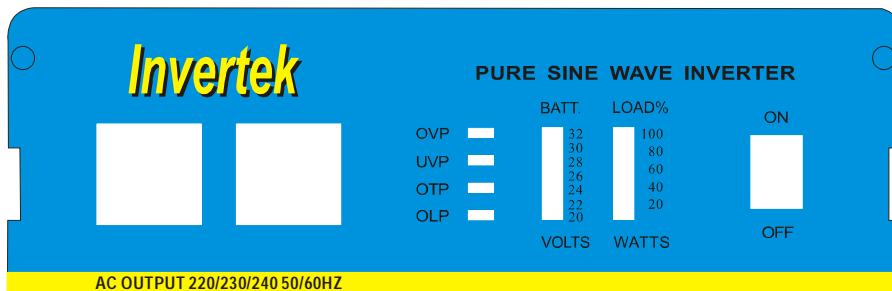
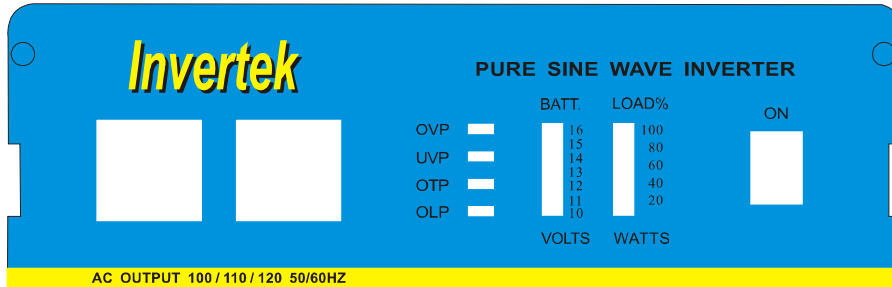

E-1-1. ON/OFF switch :

Power ON/OFF switch, leave in the OFF position during installation.

E-1-2. POWER SAVING: Power energy saving enable.

OVP : Over voltage protection.

UVP : Under voltage protection.

OVER TEMP : Over Temperature Protection.

OVER LOAD : Over Load Protection.

BATT VOLTS : Display DC Battery Input Voltage.

LOAD WATTS : Display AC Load Watts.

F. Rear View:

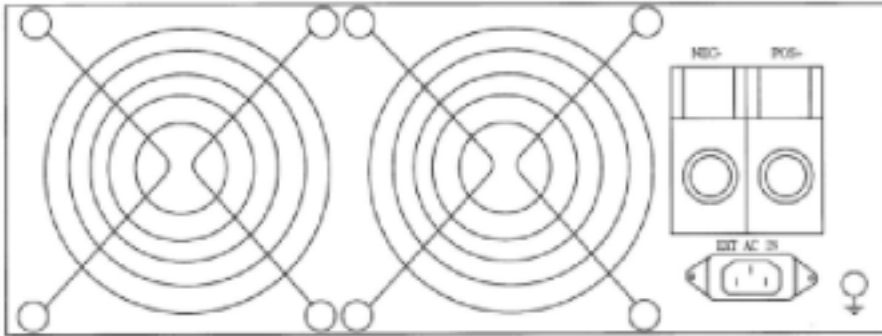

F-1. Ventilation window:

Do not obstruct, allow at least 2 inch for air flow.

F-2. Battery terminals:

Connect to 12V/ 24V/ 48V battery or other 12V/ 24V / 48V power source.

【 + 】 is positive, 【 - 】 is negative. Reverse polarity connection will blow internal fuse and may damage inverter permanently.

F-3. RS-485

Connect to remote control unit (option accessory) or taken remote controlled working status by computer.

F-4. Chassis ground or to vehicle chassis using # 8 AWG wire.



WARNING!

Operation of the inverter without a proper ground connection may result in an electrical safety hazard.



WARNING!

Shock Hazard. Before proceeding Further, ensure that the Inverter is NOT connected to any Batteries, and that all wiring is Disconnected from any electrical Sources. Do not connect the output Terminals of the Inverter to an incoming AC sources.

G. Connection And Testing:

For a quick connection and performance check, please follow these guidelines.

- G-1. Unpack and inspect the power inverter, check to see that the power switch in the OFF position.
- G-2. Connect the DC NEGATIVE cable to the Negative (NEG-) terminal on the battery. Next, connect the BLACK cable to the negative terminal on the inverter. The connection to the negative terminal of the inverter should be the last connection made. A spark when making this final connection is normal.



WARNING!

Make sure all the DC connections are tight (torque to 9-10 ft-lbs, 11.7-13 Nm). Loose connections will overheat and could result in potential hazard.

- G-3. Before proceeding further, carefully check that cable you have just connected from the negative terminal of inverter to the Negative output terminal of power source.



WARNING!

Reverse polarity connection will blow a fuse in Inverter and may permanently damage the inverter. Damage caused by reverse polarity connection is not covered by our warranty.

- G-4. Connect the RED cable from the positive terminal of inverter to the positive terminal of the power source. Make secure connection.

	<p>WARNING!</p> <p>Reverse polarity connection will blow a fuse in Inverter and may permanently damage the inverter. Damage caused by reverse polarity connection is not covered by our warranty.</p>
---	--

- G-5. Set the power switch to the ON position, the indicator lights may blink and the internal alarm may sound momentarily. This is normal.
- G-6. Check the meters and indicators on the front panel of the inverter. The voltage bar graph indicate depending on the voltage of the power source. If it does not, check your power source and the connections to the inverter. The other indicators should be off. Plug the test load into the AC receptacle on the front panel of the inverter. Leave the test load switch off.
- G-7. Set power inverter switch to the ON position and turn the test load on, the inverter should supply power to the load. If you plan to measure the true output r.m.s. Voltage of inverter, the meter such as FLUKE 45 BACKMAN 4410 or TRIPLETT 4200 or other digital meters must be used.

H. Installation:

H-1. Where to install

The power inverter should be installed in location that meets the following requirements:

H-1-1. Dry

Do not allow water to drip or splash on the inverter.

H-1-2. Cold

Ambient air temperature should be between 0 and 40 °C, the cooler the better.

H-1-3. Safe

Do not install in battery compartment or other areas where flammable fumes may exist, such as fuel storage areas or engine compartments.

H-1-4. Ventilated

Allow at least one inch of clearance around the inverter for air flow. Ensure the ventilation openings on the rear and bottom of the unit are not obstructed.

H-1-5. Dust-free

Do not install the Inverter in a dusty environment where either dust, wood particles or other filings/ shavings are present. These can be pulled into the unit when the cooling fan is operating.

H-1-6. Close to battery/ batteries

Avoid excessive cable lengths but do not install the Inverter in the same compartment as batteries. Also do not mount the Inverter where it will be exposed to the gases produced by the battery. These gases are very corrosive and prolonged exposure will damage the Inverter.

H-2. AC safety Grounding:

During the AC wiring installation, AC input and output ground wires are connected to the inverter. The AC input ground wire must connect to the incoming ground from your AC utility source.

The AC output ground wire should go to the grounding point for your loads (for example, a distribution panel ground bus.)

H-2-1. Neutral Grounding:

H-2-1-1. **120V model :**

The neutral conductor of the AC output circuit of the Inverter is automatically connected to the safety ground during inverter operation. This conforms to National Electrical Code requirements that separately derived AC sources (such as inverter and generators) have their neutral conductors tied to ground in the same way that the neutral conductor from the utility is tied to ground at AC breaker panel. For models configured with a transfer relay, when AC utility power is present and the Inverter is in bypass mode, this connection (neutral of the Inverter's AC output to input safety ground) is not present so that the utility neutral is only connected to ground at your breaker panel, as required.

H-2-1-2. **230V models:**

There is no connection made inside the Inverter from either of the line conductors (line or neutral) to the safety ground.



WARNING!

Do not operate the power inverter without connecting it to ground.

Electrical shock hazard may result.

Ground Fault Circuit Interrupters (GFCI'S)

Installations in Recreational Vehicles (for North American approvals) will require GFCI protection of all branch circuit connected to the AC output of the hardwire terminal equipped Inverter. In addition, electrical codes require GFCI protection of

certain receptacles in residential installations. While the true sine wave output of the Inverter is equivalent to the waveform provided by utilities, compliance with UL standards requires us to test and recommend specific GFCI's. State power has tested the following GFCI-protected 15A receptacles and found that they functioned properly when connected to the output of the Inverter.

H-3. Making DC Wiring Connections:

Follow this procedure to connect the battery cables to the DC input terminals on the Inverter. Your cables should be as short as possible (ideally, less than 10 feet/ 3 meters) and large enough to handle the required current, in accordance with the electrical codes or regulations applicable to your installation. Cables that are not an adequate gauge (too narrow) or are too long will cause decreased inverter performance such as poor surge capability and frequent low input voltage warnings and shutdowns.

These low input voltage warning is due to DC voltage drop across the cables from the inverter to the batteries. The longer and narrower these cables, the greater the voltage drop.

I. Operation:

To operate the power inverter, turn it on using the ON/ OFF switch on the front panel. The power inverter is now ready to deliver AC power to your loads. If you are operating several loads from the power inverter, turn them on separately after the inverter has been turned on. This will ensure that the power inverter does not have to deliver the starting currents for all the loads at once.

I-1. Controls and indicators:

The ON/ OFF switch turns the control circuit in the power inverter on and off. It does not disconnect power from the power inverter. The inverter operates from an input voltage ranging from:

10 to 16 VDC for 12V models.

20 to 32 VDC for 24V models.

42 to 62 VDC for 48V models.

Peak performance for these inverter occurs when DC input voltage is in the Range of 10 volts to 16 volts for 12V models and 20 volts to 32 volts for 24V models, and 42 volts to 62 volts for 48V models. From 600Watts up to 3000Watts.

I-2. Battery voltage indicator:

The battery voltage bar graph indicates the voltage at the input terminals of the power inverter at low input current, this voltage is very close to the battery voltage. At high input current, this voltage will be lower than the battery voltage because of the voltage drop across the cable and connections. Ideally, the voltage should remain in the green areas of the bar graph. If the voltage goes into the red area at top and bottom of the graph, inverter may shut down.

I-3. Load watt indicator:

The AC load watt bar graph indicates the power drawn from the power inverter. It will indicate watt by loads. For long term operation, the watt should in the green & orange area of the bar graph. Short-term operation is possible with watt in the red area. If the watt rises to the flash all bar, the inverter will protect it-self.

I-4. Over voltage indicator:

The over voltage indicator indicates that the power inverter has shut itself down because its input voltage has exceeded over detected voltage 12/ 24V version.

I-5. Under voltage indicator:

The under voltage indicator indicates that the power inverter has shut itself down because its input voltage has been lower than detect voltage 12/ 24V version.

I-6. Over temp indicator:

The over temp indicator indicates that the power inverter has shut itself down because it has become overheated. The power inverter may overheat because it has been operated at power levels above its rating, or because it has been installed in a location which does not allow it to dissipate heat properly. The power inverter will restart automatically once it has cooled off.

I-7. Overload indicator:

The overload indicator indicates that the power inverter has shut itself down because its output circuit has been short circuited or drastically overloaded.

Switch the ON/ OFF switch to OFF, correct the fault condition, and then switch the ON/OFF switch back to ON.

J. Operating Limits:

J-1. Power output:

The inverter will operate most AC loads within its power rating. When deeming whether a microwave oven can be operated by the inverter, remember that the power commonly advertised for microwave ovens is the cooking power (the power delivered to the food) not the power actually consumed by the microwave oven. The

microwave over will consume 40% to 100% more than its advertised cooking power. Check the rating sticker on the back of the over to determine its actual power draw.

The Power inverter may not be able to start some motors even though their rated current draw is within the power inverter. If motor refuse to start, observe the battery voltage indicator while trying to start the motor. If the battery voltage indicator drops below 11 volts while inverter is attempting to start the motor, this may be why the motor won't start. Make sure that the battery connections are good and that the battery is fully charged. If the connections are good and the battery is charged, but the voltage still drops below 11 volts, you may need to use a larger battery.

K. Trouble shooting:

K-1. Common problems Television interference:

Operation of the power inverter can interfere with television reception on some channels. If this situation occurs, the following steps may help to alleviate the problem.

Make sure that the chassis ground lug on the back of the power inverter is solidly connected to the ground system of your vehicle, boat or home.

Do not operate high power loads with the power inverter while watching television.

Make sure that the antenna feeding your television provides an adequate ("Snow free") signal and that you are using. Good quality cable between the antenna and the television.

Move the television as far away from the power

inverter as possible.

Keep the cables between the battery and the power inverter as short as possible and twist them together with about 2 to 3 twists per foot.

This minimizes radiated interference from the cables.

K-2. Troubleshooting guide:

	<p>WARNING!</p> <p>Do not open or disassemble Inverter, attempting to service the unit yourself may result in a risk of electrical shock or fire.</p>
---	--

Problem and Symptoms	Possible Cause	Solution
Low output voltage 230V- see engineer	Using average reading Voltmeter	Use true RMS and cable. See page 7 Point 6-7.of the manual.
Load LED bar flash.	Overload	Reduce load
No output voltage. And voltage indicator in lower red zone.	Low input voltage	Recharge battery. Check connections and cable.
No output voltage. Over Temp indicator on load less than: 1500W	Thermal shutdown	Improve ventilation make sure ventilation openings in inverter is not obstructed, reduce ambient temperature.
No output voltage, Over Load indicator on.	Short circuit or Wiring Error.	Check AC wiring. For short circuit or Improper polarity (hot and neutral reversed)
	Very high power load.	Remove load.

L. Maintenance:

Very little maintenance is required to keep your inverter operating properly. You should clean the exterior of the unit periodically with a damp cloth to remove accumulation of dust and dirt. At the same time, tighten the screws on the DC input terminals.

Appendix A

A-1. DIP Switch

120V Model

S1	S2	Function	S3	S4	Output Voltage	S5	Output Frequency.
OFF	OFF	DC/AC OUT MODE.	OFF	OFF	120V	OFF	60Hz
OFF	ON	DC/AC + POWER SAVING MODE.	ON	OFF	115V	ON	50Hz
ON	OFF	UPS MODE.	OFF	ON	110V		
ON	ON	UPS MODE +DELAY MODE +POWER SAVING.	ON	ON	100V		

220V Model

S1	S2	Function	S3	S4	Output Voltage	S5	Output Frequency.
OFF	OFF	DC/AC OUT MODE.	OFF	OFF	240V	OFF	60Hz
OFF	ON	DC/AC + POWER SAVING MODE.	ON	OFF	230V	ON	50Hz
ON	OFF	UPS MODE.	OFF	ON	220V		
ON	ON	UPS MODE +DELAY MODE +POWER AVING.	ON	ON	200V		

A-2.

1. DC-AC Structure schema:

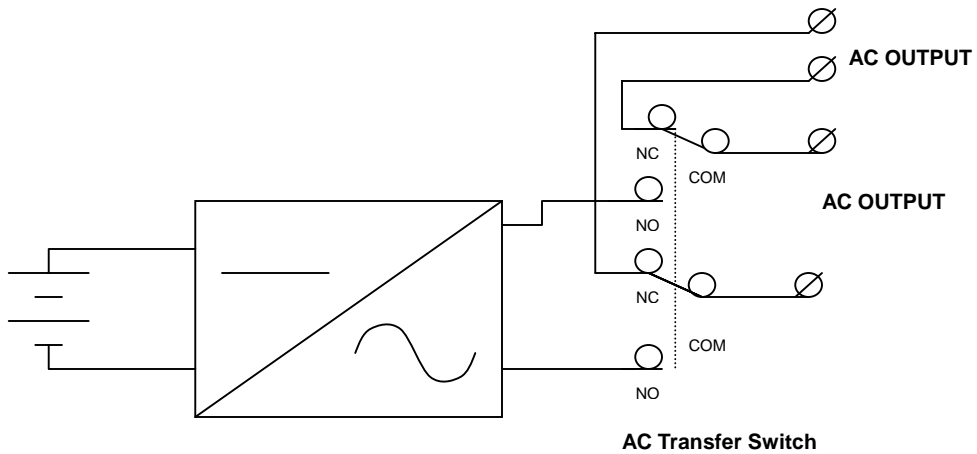

2. Code explanation

(a) DC/AC OUT MODE

No matter shore power has/ hasn't the power, the AC output is supply by DC/AC, (so the AC Transfer Switch is ON). (No Power Saving Function)

(b) DC-AC OUT MODE+POWER SAVING MODE:

AC output power supply by DC/AC (AC Transfer Switch ON) When AC output load off, DC/AC will truning to power saving mode, to reduce the consummation of the Battery.

(c) UPS MODE:

When AC input has power, the AC output power supply is by AC input, (so the AC Transfer is in Switch OFF condition), DC/AC Stand by.

When AC input cut off the power, the AC Transfer Switch will be in 10msec from OFF → ON, at this time the AC output is supply by DC/AC.

When AC input back to normal, the AC Transfer Switch from ON→ OFF, at this time the AC output power is again supply via AC input.

About AC input power at stander voltage $\pm 15\%$ change will also treat as power unusually, so it will automatically Transfer to DC/AC output, this $\pm 15\%$ Range can be setting from the Remote controller.

(d) UPS MODE + DELAY MODE + POWER SAVING:

UPS MODE + DELAY MODE:

Same as UPS mode, the only different is when AC Transfer Switch working, it won't complete in 10 msec, it will delay 5 second and than complete.

UPS MODE+DELAY MODE+POWER SAVING:

When AC input cut of the power, the AC output is via DC/AC output, and when the AC output load off, the DC/AC will turning into power saving mode, to reduce the consummation of the Battery.

High Frequency + UPS Mode

SPECIFICATION

Invertek Model No.	DAI-600U-12xx	DAI-1000U-12xx	DAI-1500U-12xx	DAI-2000U-12xx	DAI-3000U-12xx
	DAI-600U-24xx	DAI-1000U-24xx	DAI-1500U-24xx	DAI-2000U-24xx	DAI-3000U-24xx
Continuous Output power	600W	1000W	1500W	2000W	3000W
Output power surge	800W	1400W	2000W	2800W	4200W
AC Output voltage	100/110/120V \pm 2% ; 220V/ 230/ 240V \pm 2% DIP switch select				
Output voltage Regulation	-8% / + 3%				
Output frequency	50/ 60 Hz selectable \pm 0.05% Accuracy				
Output Wave form	Pure Sine Wave < 3% THD				
Efficiency (Full Load)	83% ~ 85%				
No Load power consumption	< 1.5W (In power saving mode.)				
Input voltage range	10V – 16VDC, 20V – 32VDC				
Input Voltage (UPS-mode)	126 ~ 93 Vac				
Power saving recovery time	1 second				
AC Transfer time (UPS-mode)	< 10 msec max				
LED status indicators	High/ Low battery shutdown, over temperature shutdown, overload shutdown/ input DC voltage scale meter & output watts percent scale metter				
Protection Feature	Over load, short circuit, over/ under input voltage, over temperature, reverse input polarity				
Remote controller option	(by fuse)				
RS485 Remote controller	Power output ON/OFF, power saving mode, reset, error message, ...etc.				
Opertation temperature range	0 ~ 50 (32 ~ 122)				
Storage temperature range	-30 ~ 70				
Dimensions (LxWxH) mm	350 x 285 x 120	410 x 285 x 120	450 x 285 x 120	410 x 285 x 185	490 x 285 x 185
Weight	4.5 Kgs	5.5 Kgs	7 Kgs	10 Kgs	12 Kgs

- Remote controller is optional
- DAI-2000U-xxxx coming soon

RICH
ELECTRIC