

# EI-500 Series

220V Class 1HP~7½ HP

440V Class 1HP~10 HP

**Read this manual carefully before installing, wiring, operating, servicing or inspecting the drive.  
Keep this manual within easy reach for quick reference.**

**RICH**  
ELECTRIC

**RICH ELECTRIC CO., LTD.**





---

*Thank you for purchasing ERIC-500 Variable Speed Drives!*

## SAFETY INSTRUCTIONS

- Always follow safety instructions to prevent accidents and potential hazards from occurring.
- In this manual, safety messages are classified as follows:

 **WARNING** Improper operation may result in serious personal injury or death.

 **CAUTION** Improper operation may result in slight to medium personal injury or property damage.

- Throughout this manual we use the following two illustrations to make you aware of safety considerations:



Identifies potential hazards under certain conditions.  
Read the message and follow the instructions carefully.



Identifies shock hazards under certain conditions.  
Particular attention should be directed because dangerous voltage may be present.

- Keep operating instructions handy for quick reference.
- Read this manual carefully to maximize the performance of EI-500 series inverter and ensure its safe use.

## **WARNING**

- **Do not remove the cover while power is applied or the unit is in operation.**  
Otherwise, electric shock could occur.
- **Do not run the inverter with the front cover removed.**  
Otherwise, you may get an electric shock due to high voltage terminals or charged capacitor exposure.
- **Do not remove the cover except for periodic inspections or wiring, even if the input power is not applied.**  
Otherwise, you may access the charged circuits and get an electric shock.
- **Wiring and periodic inspections should be performed at least 10 minutes after disconnecting the input power and after checking the DC link voltage is discharged with a meter (below DC 30V).**  
Otherwise, you may get an electric shock.

- 
- **Operate the switches with dry hands.**  
Otherwise, you may get an electric shock.
  - **Do not use the cable when its insulating tube is damaged.**  
Otherwise, you may get an electric shock.
  - **Do not subject the cables to scratches, excessive stress, heavy loads or pinching.**  
Otherwise, you may get an electric shock.



## CAUTION

- **Install the inverter on a non-flammable surface. Do not place flammable material nearby.**  
Otherwise, fire could occur.
- **Disconnect the input power if the inverter gets damaged.**  
Otherwise, it could result in a secondary accident and fire.
- **After the input power is applied or removed, the inverter will remain hot for a couple of minutes.**  
Otherwise, you may get bodily injuries such as skin-burn or damage.
- **Do not apply power to a damaged inverter or to an inverter with parts missing even if the installation is complete.**  
Otherwise, electric shock could occur.
- **Do not allow lint, paper, wood chips, dust, metallic chips or other foreign matter into the drive.**  
Otherwise, fire or accident could occur.

## OPERATING PRECAUTIONS

### (1) Handling and installation

- Handle according to the weight of the product.
- Do not stack the inverter boxes higher than the number recommended.
- Install according to instructions specified in this manual.
- Do not open the cover during delivery.
- Do not place heavy items on the inverter.
- Check the inverter mounting orientation is correct.

- Do not drop the inverter, or subject it to impact.
- Use the Type 3 grounding method for 220 V Class and special Type 3 for 440V class.  
(Ground impedance: Below 100 ohm).
- Take protective measures against ESD (Electrostatic Discharge) before touching the pcb for inspection or installation.
- Use the inverter under the following environmental conditions:

Environment	Ambient temperature	- 10 ~ + 50 (non-freezing)
	Relative humidity	90% RH or less (non-condensing)
	Storage temperature	- 20 ~ + 60
	Location	Protected from corrosive gas, combustible gas, oil mist or dust
	Altitude, Vibration	Max. 1,000m above sea level, Max. 5.9m/sec <sup>2</sup> (0.6G) or less
	Atmospheric pressure	70 ~ 106 kPa

## (2) Wiring

- Do not connect a power factor correction capacitor, surge suppressor, or RFI filter to the output of the inverter.
- The connection orientation of the output cables U/T1, V/T2, W/T3 to the motor will affect the direction of rotation of the motor.
- Incorrect terminal wiring could result in the equipment damage.
- Reversing the polarity (+/-) of the terminals could damage the inverter.
- Only authorized personnel familiar with ERIC inverter should perform wiring and inspections.
- Always install the inverter before wiring. Otherwise, you may get an electric shock or have bodily injury.

## (3) Trial run

- Check all parameters during operation. Changing parameter values might be required depending on the load.
- Always apply permissible range of voltage to the each terminal as indicated in this manual. Otherwise, it could lead to inverter damage.

---

#### (4) Operation precautions

- When the Auto restart function is selected, stay away from the equipment as a motor will restart suddenly after an alarm stop.
- The “STOP” key on the keypad is valid only when the appropriate function setting has been made. Prepare an emergency stop switch separately.
- If an alarm reset is made with the reference signal present, a sudden start will occur. Check that the reference signal is turned off in advance. Otherwise an accident could occur.
- Do not modify or alter anything inside the inverter.
- Motor might not be protected by electronic thermal function of inverter.
- Do not use a magnetic contactor on the inverter input for frequent starting/stopping of the inverter.
- Use a noise filter to reduce the effect of electromagnetic interference. Otherwise nearby electronic equipment may be affected.
- In case of input voltage unbalance, install AC reactor. Power Factor capacitors and generators may become overheated and damaged due to potential high frequency noise transmitted from inverter.
- Use an insulation-rectified motor or take measures to suppress the micro surge voltage when driving 440V class motor with inverter. A micro surge voltage attributable to wiring constant is generated at motor terminals, and may deteriorate insulation and damage motor.
- Before operating unit and prior to user programming, reset user parameters to default settings.
- Inverter can easily be set to high-speed operations, Verify capability of motor or machinery prior to operating unit.
- Stopping torque is not produced when using the DC-Break function. Install separate equipment when stopping torque is needed.

#### (5) Fault prevention precautions

- Provide a safety backup such as an emergency brake which will prevent the machine and equipment from hazardous conditions if the inverter fails.

#### (6) Maintenance, inspection and parts replacement

- Do not conduct a megger (insulation resistance) test on the control circuit of the inverter.
- Refer to Chapter 6 for periodic inspection (parts replacement).

---

(7) Disposal

- Handle the inverter as an industrial waste when disposing of it.

(8) General instructions





- Many of the diagrams and drawings in this instruction manual show the inverter without a circuit breaker, a cover or partially open. Never run the inverter like this. Always place the cover with circuit breakers and follow this instruction manual when operating the inverter.

---

# CONTENTS

<b>CHAPTER 1 INSTALLATION.....</b>	<b>3</b>
Inspection.....	3
Environmental Conditions.....	3
Mounting.....	3
Other Precautions.....	4
Dimensions.....	5
Standard Wiring.....	8
Terminal Description.....	9
Wiring Power Terminals.....	10
Wires and Terminal Specification.....	12
Control Terminals.....	13
Control Terminals Wiring.....	14
<b>CHAPTER 2 TEST RUN.....</b>	<b>15</b>
Digital Operator (RCU-500) Operation.....	15
Constant Setting and Change.....	16
Constant Group.....	19
Test Run.....	21
<b>CHAPTER 3 CONSTANTS LIST.....</b>	<b>22</b>
Function Group U (Drive Group).....	22
Function Group A (Standard Group).....	23
Function Group b (Application Group).....	25
Function Group C (Multi-function Terminal Constant Group).....	28
<b>CHAPTER 4 CONSTANT.....</b>	<b>31</b>
Function Group U (Drive Group).....	31
Function Group A (Standard Group).....	39
Function Group b (Application Group).....	56
Function Group C (Multi-function Terminal Constant Group).....	72
<b>CHAPTER 5 TROUBLESHOOTING AND MAINTENANCE.....</b>	<b>92</b>
Fault Display.....	92
Fault Remedy.....	95
Troubleshooting.....	97
Check Power Components (IGBT).....	98

## Standard Specification

Voltage Class		220V Class Single-phase			220V Class 3-phase					440V Class 3-phase						
Model EI-500-		S1L	S2L	S3L	01L	02L	03L	05L	07L	01H	02H	03H	05H	07H	10H	
Max. Application Motor Output (HP)		1	2	3	1	2	3	5	7.5	1	2	3	5	7.5	10	
Max. Application Motor Output (KW)		0.75	1.5	2.2	0.75	1.5	2.2	3.7	5.5	0.75	1.5	2.2	3.7	5.5	7.5	
Output Features	Rated Output Current (A)	5	8	12	5	8	12	16	25	2.5	4	6	8	15	18	
	Max. Output Voltage (V)	3-phase 200~230V (Proportional to input voltage)			3-phase 200~230V (Proportional to input voltage)					3-phase 380~460V (Proportional to input voltage)						
	Max. Output Frequency (Hz)	400Hz (Programmable)														
Power Supply	Rated Input Voltage and Frequency	Single-phase 200~230V 50/60Hz			3-phase 200~230V 50/60Hz					3-phase 380~460V 50/60Hz						
	Allowable Voltage Fluctuation	-15+10%														
	Allowable Frequency Fluctuation	±5%														
Control Features	Control Method	V/F Control (SVPWM)														
	Frequency Setting Resolution	Digital reference : 0.01Hz (less than 100Hz), 0.1 Hz (100Hz or more) Analog reference : 0.03Hz/ 50Hz														
	Frequency Accuracy	Digital reference : 0.015 of Max. Output Frequency. Analog reference : 0.1% of Max. Output Frequency.														
	V/F Ratio	Linear, Square Pattern, User V/F														
	Overload Capacity	150% rated output current for one minute. (Characteristic is inversely proportional to time)														
	Torque Boost	Manual torque boost (0~15%) ; Auto torque boost														
Dynamic Braking	Average Braking Torque	Continuous regenerative torque : Approx. : 20% (150% with optional braking resistor, braking resistor built-in)														
	Max. Continuous Braking Time	15 seconds														
Operation Features	Input Signal	Operation Method	  key of digital operation/ External terminal S1, S2/ Communication Port													
		Frequency Setting	Digital reference :   key of RCU-500/ Communication Port Analog reference : 0~10V/ 4~20mA (External terminal)/ Potentiometer of digital operator													
		Start Signal	Forward/ Reverse													
		Multi-step Speed	Up to 8 speed can be set (Use Multi-function terminal)													
		Multi-step Accel/ Decel Time	0 ~ 999.9 sec, Up to 8 types can be set and selected for each setting (Use Multi-function terminal) Accel/ Decel Pattern : Linear Pattern, U Pattern, S Pattern													
		Emergency Stop	Interrupts the output of Inverter													
		S5	Jog Operation													
	Fault Reset	Reset faults when protective function is active.														
	Output Signal	Operation Status	Frequency level detection, overload alarm, over current, over voltage, under voltage, inverter overheat, running, stop, constant speed, speed searching													
		Fault Output	Contact output (MA, MC, MB) – AC250V 1A/ DC 30V 1A													
Indicator		Output frequency, output current, output voltage, DC voltage indicator selection (Output pulse : 500Hz, Output Voltage : 0~10V)														
Operation Function		DC braking, frequency limit, frequency jump, second function, slip compensation, reverse rotation prevention, auto restart, PID control														

Protection	Inverter Trip		Over voltage, under voltage, over current, inverter overheat, motor overheat, input/ output phase loss, overload protection, communication error, speed command loss, hardware fault
	Inverter Alarm		Stall prevention, overload alarm
	Momentary Power Loss		Less than 15 msec. : Continuous operation More than 15 msec. : Auto restart
Display	RCU-500	Operation Information	Output frequency, output current, output voltage, frequency value setting, DC voltage
		Trip Information	Indicates fault when protection function is activated, up to 5 faults can be memorized.
Environment	Ambient Temperature		-10 ~50 (Atmospheric Pressure : 70-106kPa)
	Storage Temperature		-20 ~60
	Humidity		Less than 90% RH Max.
	Altitude/ Vibration		1,000M or less, 5.9m/ sec <sup>2</sup> (=0.6g) or less
	Application Site		No corrosive gas, combustible gas, oil mist, or dust
Cooling Method			Forced Air Cooling



## Other Precautions

- Do not carry the inverter by the front cover.
- Do not install the inverter in a location where excessive vibration is present. Be cautious when installing on presses or moving equipment.
- The life span of the inverter is greatly affected by the ambient temperature. Install in a location where temperature are within permissible limits (- 10 ~ + 50 ).
- The inverter operates at high-temperatures - install on a non-combustible surface.
- Do not install the inverter in high-temperature or high-humidity locations.
- Do not install the inverter in a location where oil mist, combustible gas, or dust is present. Install the inverter in a clean location or in an enclosed panel, free of foreign substance.
- When installing the inverter inside a panel with multiple inverters or a ventilation fan, use caution.
- If installed incorrectly, the ambient temperature may exceed specified limits.

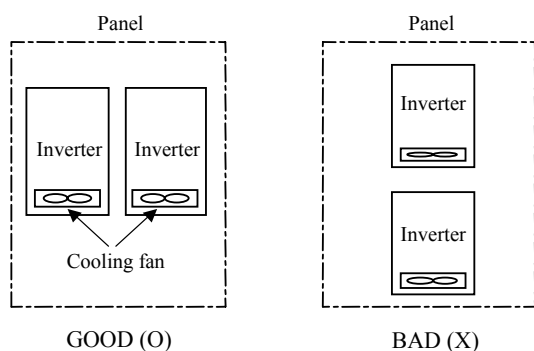

[When installing several inverters in a panel]

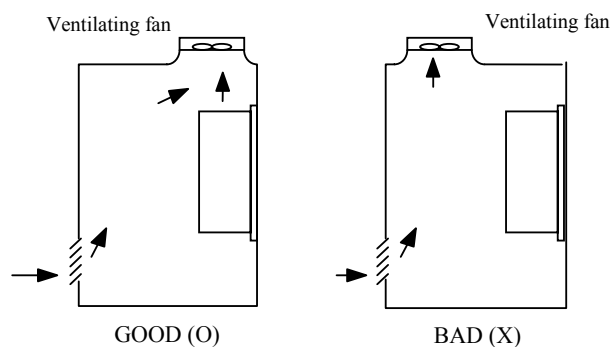

[When installing a ventilating fan in a panel]

- Install the inverter using screws or bolts to insure the inverter is firmly fastened.

# Dimensions

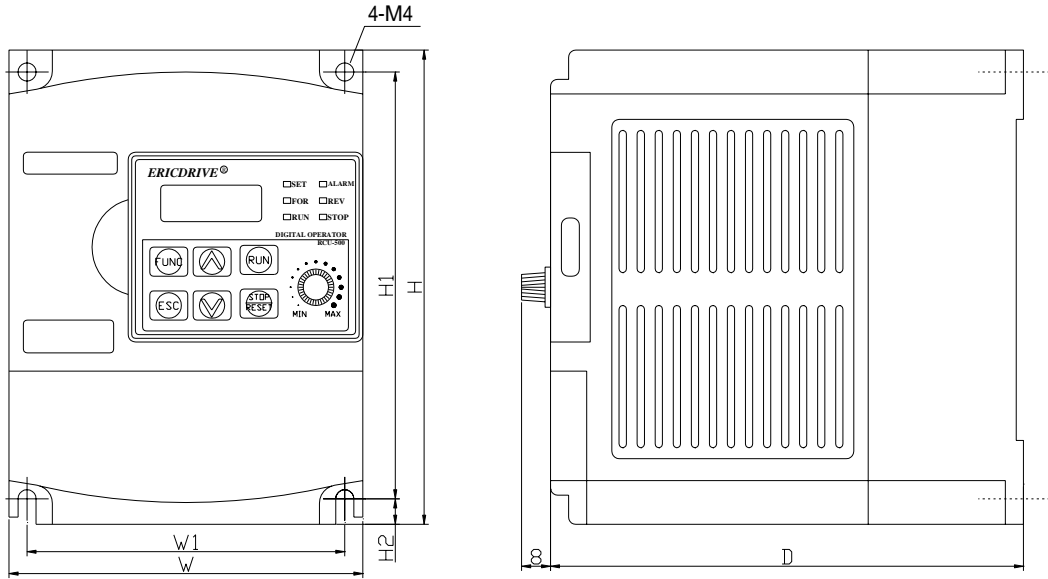

Fig.1

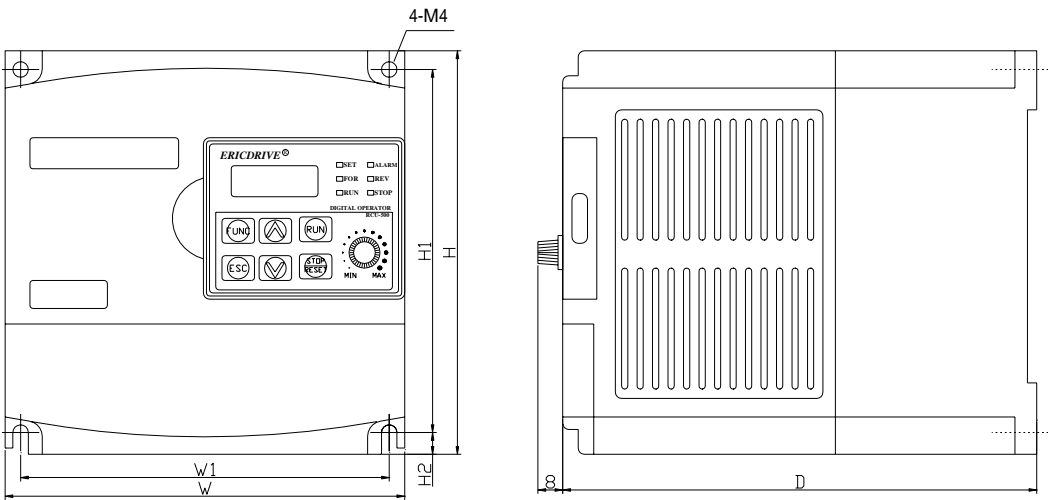

Fig.2

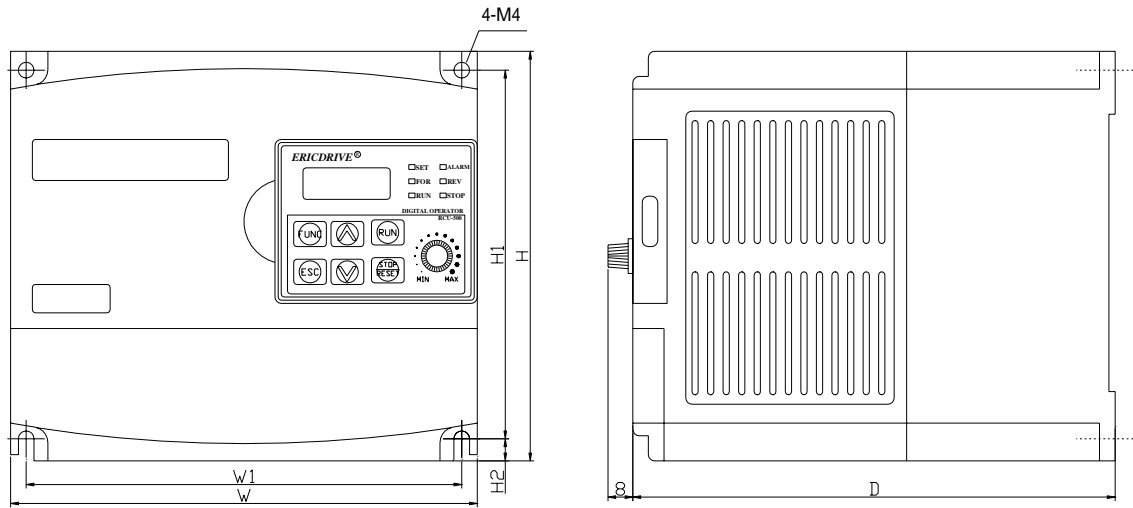

Fig.3

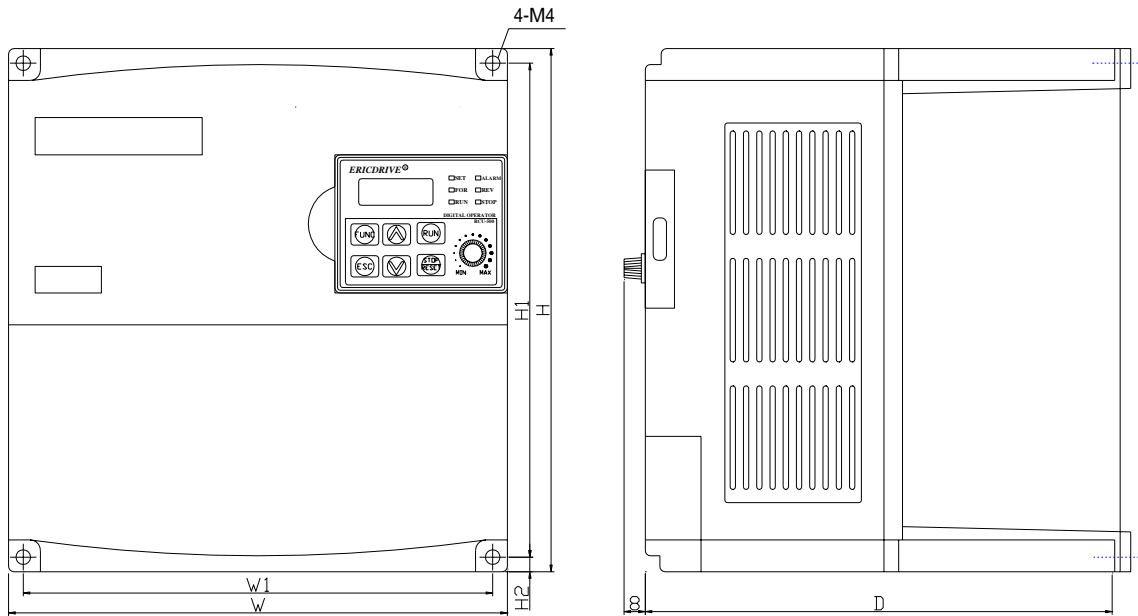

Fig.4

---

**Dimension in mm/Mass in kg**

Voltage Class	Capacity (HP)	W	H	D	W1	H1	H2	Mass	Fig.
220V Signal-Phase	1HP	98	130	131	88	117	7	0.9	1
	2HP	129	130	153	117	118	6	1.5	2
	3HP	150	130	155	137	117	7	1.8	3
220V 3-Phase	1HP	98	130	131	88	117	7	0.9	1
	2HP	129	130	153	117	118	6	1.5	2
	3HP	150	130	155	137	117	7	1.8	3
	5HP								
7.5HP	190	200	186	176	185.5	5	3.8	4	
440V 3-Phase	1HP	98	130	131	88	117	7	0.9	1
	2HP	129	130	153	117	118	6	1.5	2
	3HP	150	130	155	137	117	7	1.8	3
	5HP								
	7.5HP	190	200	186	176	185.5	5	3.8	4
	10HP								

# Standard Wiring

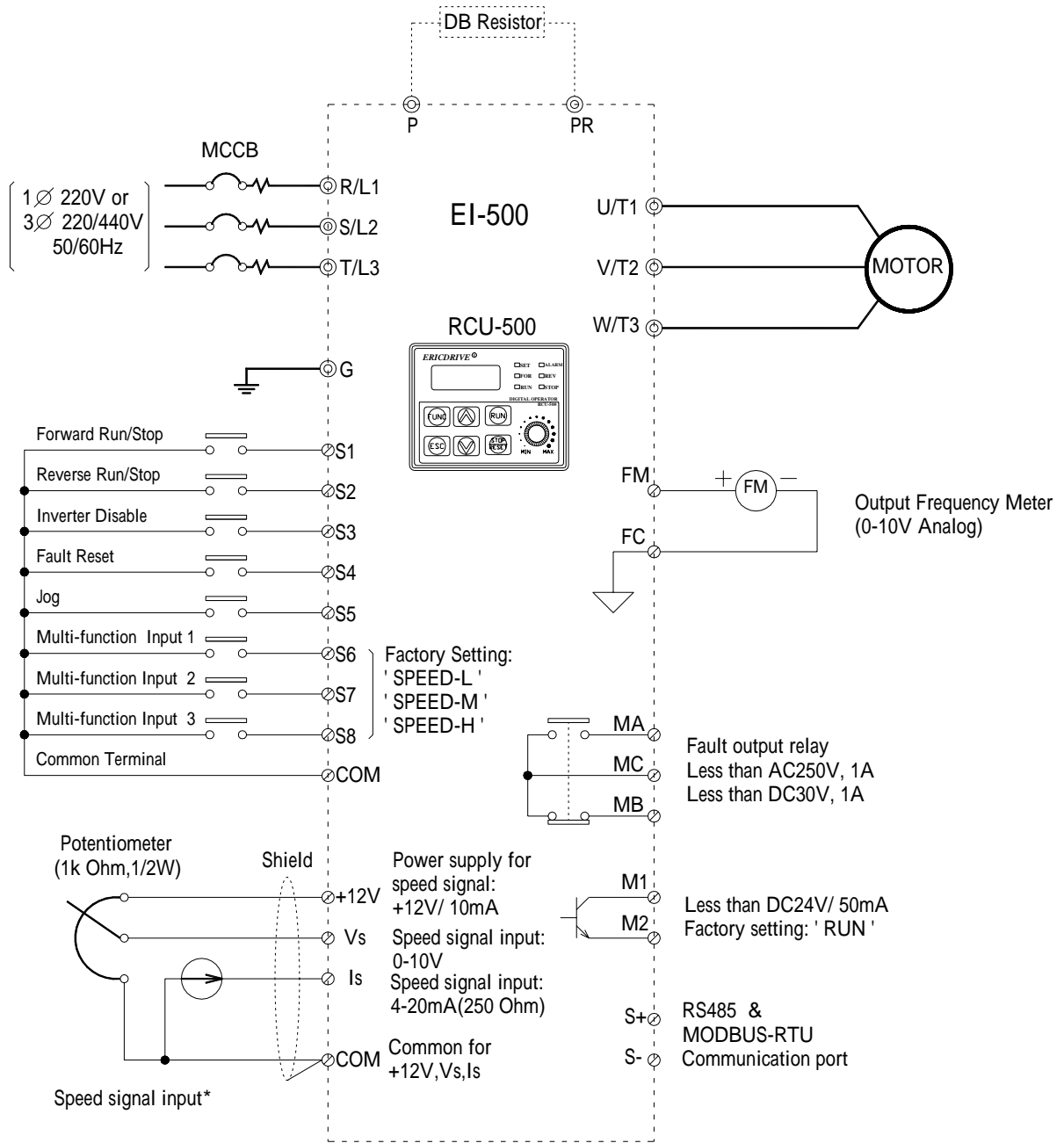

\* Analog speed command can be set by Voltage, Current and both them.

## Terminal Description

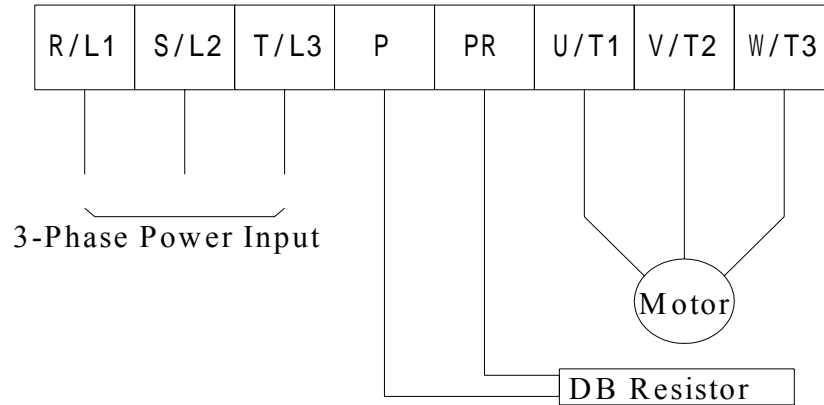

Symbols	Functions
R/ L1	AC Line Input Terminals 3(1) phase, 200 ~ 230V AC for 220V Class Units and 380 ~ 460V AC for 440V Class Units.
S/ L2	
T/ L3	
U/ T1	3 Phase Output Terminals to Motor
V/ T2	
W/ T3	
P	Dynamic Braking Resistor Connection Terminals
PR	



## WARNING

Normal stray capacitance between the inverter chassis and the power devices inside the inverter and AC line can provide a high impedance shock hazard. Do not apply power to the inverter if the inverter frame is not grounded.

---

## **Wiring Power Terminals**

### **Precautions on Wiring**

- ❑ The internal circuits of the inverter will be damaged if the incoming power is connected and applied to output terminals (U/ T1, V/ T2, W/ T3).
- ❑ Use ring terminals with insulated caps when wiring the input power and motor wiring.
- ❑ Do not leave wire fragments inside the inverter. Wire fragments can cause faults, breakdowns, and malfunctions.
- ❑ For input and output, use wires with sufficient size to ensure voltage drop of less than 2%.
- ❑ When more than one motor is connected to one inverter, total wiring length should be less than 100m (1,640ft). Do not use a 3-wire cable for long distances. Due to increased leakage capacitance between wires, over-current protective feature may operate or equipment connected to the output side may malfunction.
- ❑ Connect only recommended braking resistor between the P and PR terminals. Never short P and PR terminals. Shorting terminals may cause internal damage to inverter.
- ❑ The main circuit of the inverter contains high frequency noise, and can hinder communication equipment near the inverter. To reduce noise, install RFI filters or line noise filters on the input side of the inverter.
- ❑ Do not use power factor capacitor, surge suppressors, or RFI filters on the output side of the inverter. Doing so may damage these components.
- ❑ Always insure the LED and charge lamp for the power terminal are OFF before wiring terminals. The charge capacitor may hold high-voltage even after the power is disconnected. Use caution to prevent the possibility of personal injury.

---

## Grounding

- ❑ The inverter is a high switching device, and leakage current may flow. Ground the inverter to avoid electrical shock. Use caution to prevent the possibility of personal injury.
- ❑ Connect only to the dedicated ground terminal on the inverter. Do not use the enclosure or a chassis screw for grounding.
- ❑ As a minimum, grounding wire should meet the specifications listed below. Grounding wire should be as short as possible and should be connected to the ground point as near as possible to the inverter.

Motor Capacity	Grounding Wire Sizes, AWG (mm <sup>2</sup> )	
	220V class	440V class
1.0 ~ 5.0 HP	12 (3.5)	14 (2)
7.5 ~ 10 HP	12 (3.5)	12 (3.5)

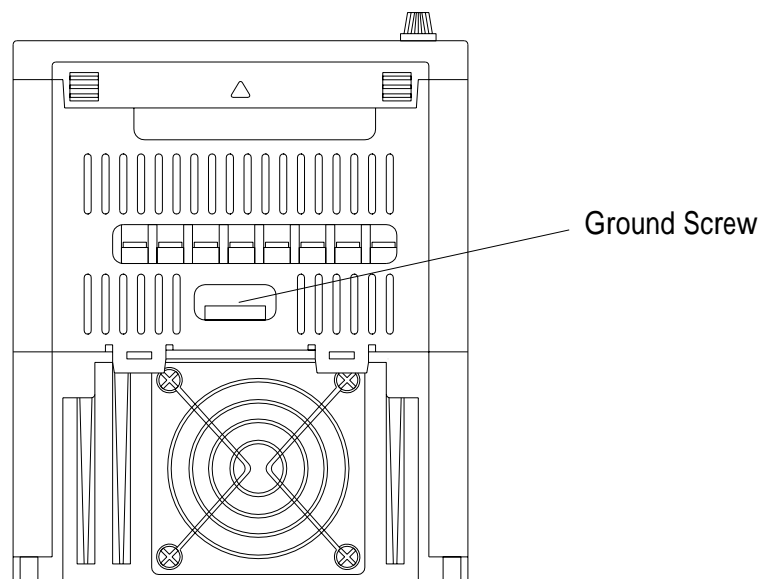

## Wires and Terminal Specification

Refer to the following table for wires and terminal specification of the inverter power input (R/L1, S/L2, T/L3) and output (U/T1, V/T2, W/T3).

Inverter Capacity		Terminal Screw Size	Screw Torque <sup>1</sup> (Kgf·cm)/ lb-in	Terminals		Wire <sup>2</sup>			
						mm <sup>2</sup>		AWG	
				R/L1, S/L2, T/L3	U/T1, V/T2, W/T3	R/L1, S/L2, T/L3	U/T1, V/T2, W/T3	R/L1, S/L2, T/L3	U/T1, V/T2, W/T3
220V Class (Single-Phase)	1 ~ 3 HP	M 4.0	15/10	2 - 4	2 - 4	2	2	14	14
220V Class (3 - Phase)	1 HP	M 3.5	10/ 7	2 - 3.5	2 - 3.5	2	2	14	14
	2 ~ 3 HP	M 4.0	15/10	2 - 4	2 - 4	2	2	14	14
	5.0 HP	M 4.0	15/10	5.5 - 4	5.5 - 4	3.5	3.5	12	12
	7½ HP	M 4.0	25/16	5.5 - 4	5.5 - 4	5.5	5.5	10	10
440V Class (3 - Phase)	1.0 ~ 5.0 HP	M 4.0	15/10	2 - 4	2 - 4	2	2	14	14
	7½ HP ~ 10HP	M 4.0	25/16	5.5 - 4	5.5 - 4	5.5	5.5	10	10

## Power and Motor Connection

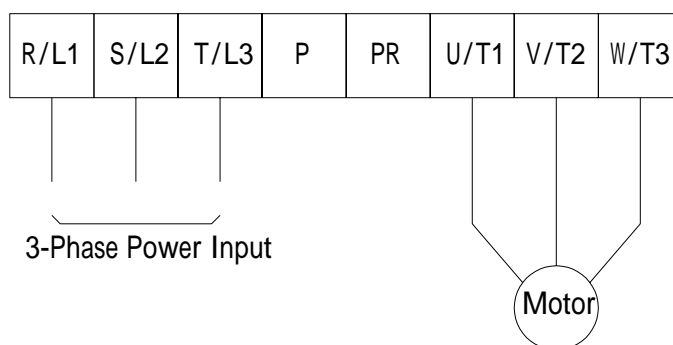

### Power supply must be connected to the R/L1, S/L2, and T/L3 Terminals.

Connecting it to the R/L1, S/L2, T/L3 terminals causes internal damages to the inverter.

Arranging the phase sequence is not necessary.

### Motor should be connected to the U/T1, V/T2, and W/T3 Terminals.

If the forward command (S1) is on, the motor should rotate clockwise when viewed from the load side of the motor. If the motor rotates in the reverse, switch the U/T1 and V/T2 Terminals.

<sup>1</sup> Apply the rated torque to terminal screws. Loosen screws can cause short circuit and malfunction. Tightening the screws too much can damage the terminals and cause short circuit and malfunction.

<sup>2</sup> Use copper wires with 600V, 75 ratings for wiring only.

## Control Terminals

1 MA	2 MC	3 MB
---------	---------	---------

1	2	3	4	5	6	7	8	9	10	11	12	13	14	15	16	17	18	19	20
COM	S1	S2	S3	S4	S5	S6	S7	S8	COM	+12	Vs	COM	Is	FM	FC	M1	M2	S+	S-

Type	Symbol	Name	Description	
Input Signal	Starting Contact Function Selection	S1	Forward Run Command	Forward run when closed and stop when open.
		S2	Reverse Run Command	Reverse run when closed and stop when open.
		S3	Emergency Stop	When the S3 signal is ON, output of Inverter is turned Off. When motor uses an electrical brake to stop, S3 is used to turn Off the output signal. When S3 signal is OFF (Not turned off by latching) and S1 Signal (or S2 Signal) is ON, motor continues to run.
		S4	Fault Reset	Used for fault reset.
		S5	Jog Frequency Reference	When Jog frequency is ON, operating at low frequency. The direction is set by the S1 (or S2) Signal.
		S6, S7, S8	Multi-function input 1, 2, 3	Used for multi-function input. Default is set to “Step Frequency 1, 2, 3”.
	Analog frequency setting	COM	Sequence Common	Common terminal for contact inputs.
		+12V	Frequency Reference Power (+12)	Used as power for analog frequency setting. Maximum output is +12V/ 100mA
		Vs	Frequency Reference Input Signal (Voltage)	Used for DC 0 ~ +10V input frequency reference. Input resistance is 20 K $\Omega$
		Is	Frequency Reference Input Signal (Current)	Used for DC 4-20mA input frequency reference. Input resistance is 250 $\Omega$
		COM	Frequency Reference Common Terminal	Common Terminal for Analog Frequency Reference Signal
	Output Signal	Analog Output	FM-FC	Analog/ Digital Output (for External Monitoring)
Relay Contact		MA MC MB	Fault Contact Output	Activates when Protective Function is Operating. AC250V/ 1A, DC30V/ 1A for Contact capacity Fault : MA-MC close (MB-MC open), Normal : MB-MC close (MA-MC open)
Transistor		M1-M2	Multi-function Output (Open Collector Output)	Use After Defining Multi-function Output Terminal. DC24V, 50mA or less.
RS-485	S+, S-	MODBUS Communication Port	RS485 Communication Port for protocol MODBUS-RTU Communication	

---

## Control Terminals Wiring

### Precautions on Wiring

- COM and M2 Terminal are mutually separated. Do not connect these two terminals to each other. Meanwhile, do not connect COM and M2 Terminal to power source.
- Use shielded wires or twisted wires for control circuit wiring, and separate these wires from the main power circuits and other high voltage circuits. (Example : 220V Relay sequence circuit.)
- Use 1.25 mm<sup>2</sup> (22AWG) standard cable for control terminal wire.

### Control Circuit Terminal

SW1 could adjust the digital input signal (S1~S8) level, when S1 to S8 common terminal is 0 V, SW1 is located at NPN and use 24 V power source Inside Inverter.

When S1 to S8 Common Terminal is added with 24 V power source, SW1 is located at PNP. (Factory default of SW1 is located at NPN side.)

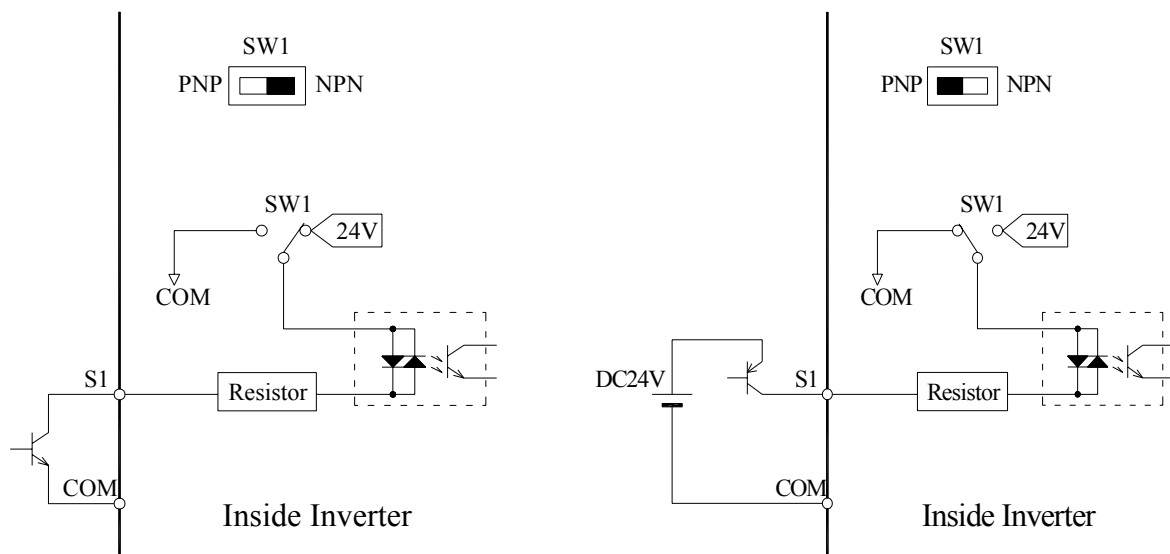

## CHAPTER 2 TEST RUN

### Digital Operator (RCU-500) Operation

EI-500 offers 4 types of function groups. It can be adjusted by Digital Operator (RCU-500) and input by constant settings directly. The following is an illustration and functions of the RCU-500.

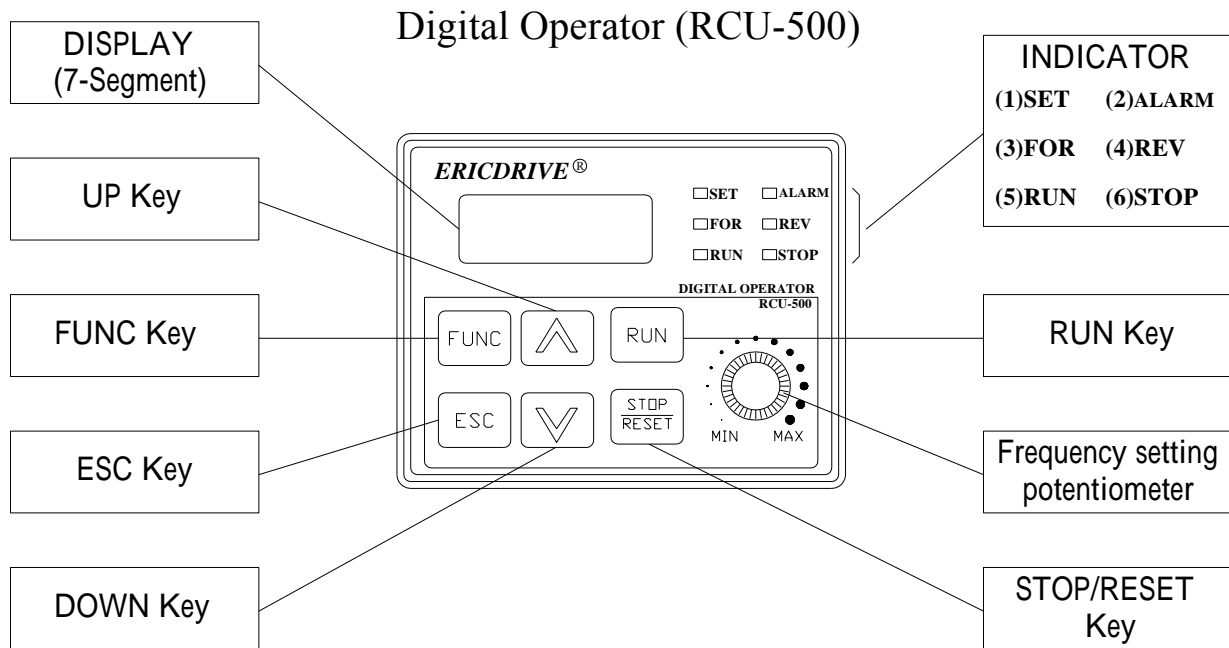

Class	Display	Description
Key	FUNC	Press to Change/ Adjust constant setting.
	ESC	Exit key of function group U, A, b, C
	▲ (Up)	Press to move through constants or to increase/ adjust constant values.
	▼ (Down)	Press to move through constants or to decrease/ adjust constant values.
	RUN	Use to operate inverter.
	STOP/RESET	Press to stop inverter during operation. Press to reset when a fault has occurred.
LED	SET	Lit when user is setting constants by using FUNC key
	ALARM	Lit when the inverter has fault trip.
	FWD	Lit during forward run.
	REV	Lit during reverse run.
	RUN	Lit when at constant speed and blinks when accelerating or decelerating.
	STOP	Lit during the inverter has STOP the output status.

---









## Constant Setting and Change

Numerous parameters are built into the inverter (EI-500). Basically, it can be divided into 4 groups, there are :











- (1) U Function Group (Drive Group)
- (2) A Function Group (Basic Group)
- (3) b Function Group (Application Group)
- (4) C Function Group (Multi-function Terminal Group)

The digital operator RCU-500 allows to operate the inverter by setting the required parameters, and adjusting, monitoring their value according to the load and operating conditions.

### ■ Function Group U ( U-01 ~ U-13) Operation Procedures

1. Move to the group code that needs changing by using   key.
2. Press  key. The keypad LED (**SET**) will turn ON.
3. Use   keys to set the parameter value.
4. Press   again upon the parameter value has been settled. The 7-segment display will blink for 3 times. (i.e. the parameter values have been settled completely.) At the same time, the keypad LED (**SET**) will turn OFF.
5. If the parameter value needs to get back to original value before pressing  , please press  key (The keypad LED (**SET**) will turn OFF).

### ■ A Function Group, b Function Group, C Function Group Operation Procedures

1. Use   keys to move to desired Function Group.
2. Press  key to enter the desired Function Group.
3. Use the   keys to set the parameter value to the desired code.
4. Press  key (The keypad LED **SET** will turn ON.), and enter to the value of constant code.
5. Use   keys to set and adjust the parameter value.
6. Press  key again once the parameter value has been settled when the 7-segment display will blink for 3 times, the renewed values have been stored in the inverter. Meanwhile, the keypad LED (**SET**) will turn OFF.
7. To exit the Function Group, please press  key, then return to the Step 1.

If the parameter value can not be changed/ adjusted, determine if :

The value of constant attribute can't be adjusted while inverter is running. (Refer to the function table in Chapter 3.)

The Function might be locked in b-94 [Constants Write Protection]. (Refer to the constant description in Chapter 4.)

- [Example] Change the deceleration time in U-02 from 60 sec to 40 sec.

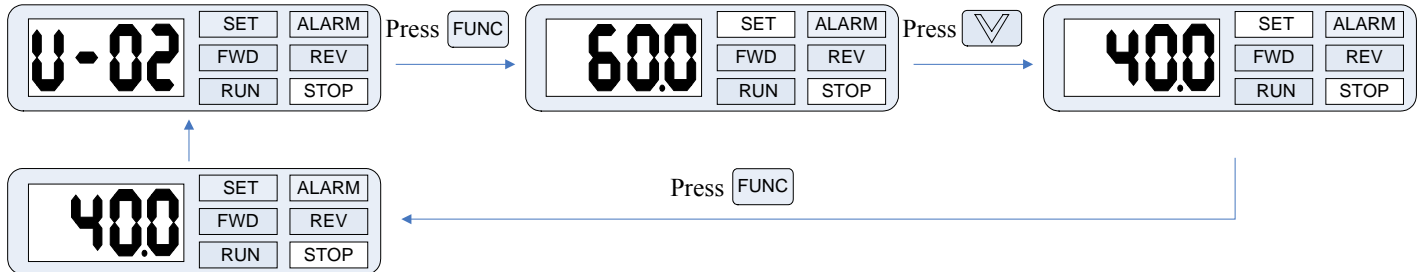

“ The 7-segment display will blink for 3 times ”

After the data setting is finished, press **FUNC** key. The new data will blinks for 3 times when the data setting is finished. It indicates data programming is completed.

- [Example] To Monitor Current Output in U-08 from the inverter while the inverter is running (U-08 cannot be set)

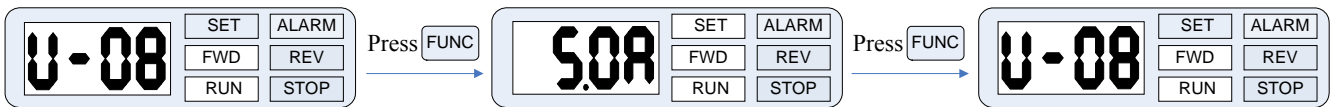

- [Example] To Monitor Fault Type when a Fault Occurs in U-12

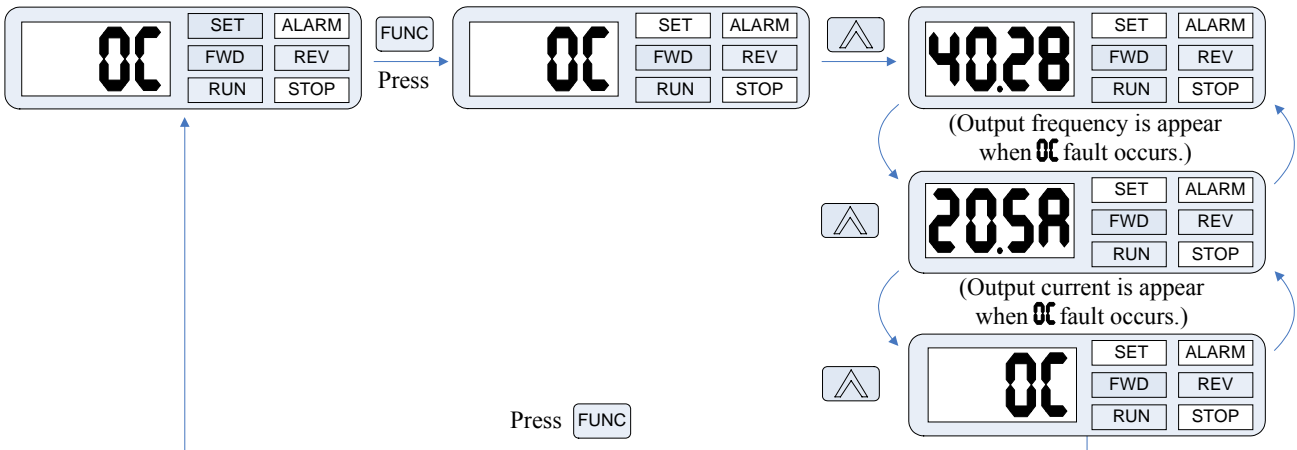

The fault type is auto-displayed in U-12 on operator when a fault occurs. Frequency, current and operating status (accelerating, decelerating, in constant speeds) may be monitored by using the UP/DOWN key. Example : Fault occurs when the inverter was accelerating at 40.28Hz, 20.5A, the keypad LED (**ALARM**) will blink. (The inverter must be turned OFF and turned ON again to remove the OC fault.)

■ [Example] Adjusting Procedure for the parameter value of A Function Group when the inverter stops. (A-05=1)

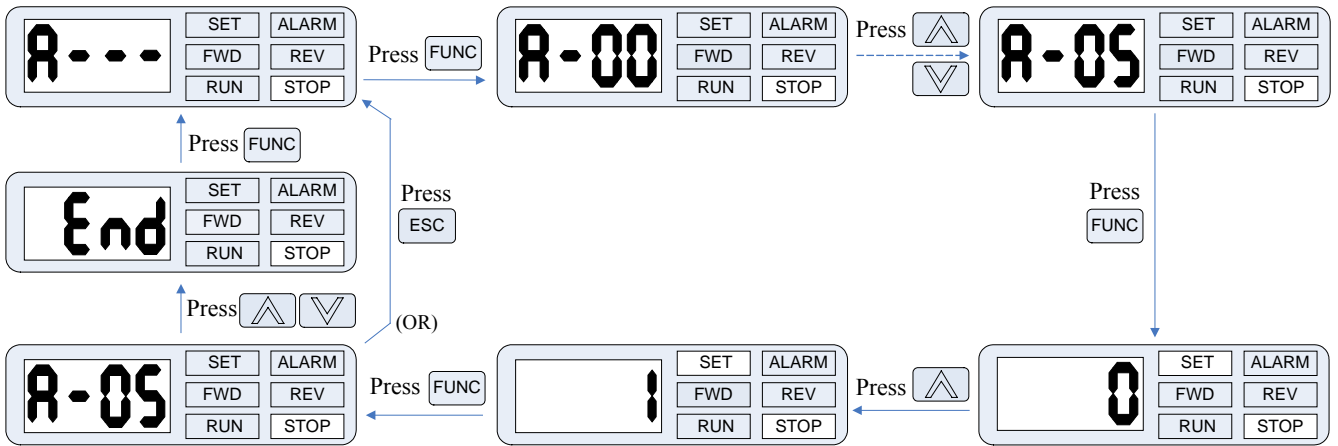

■ [Example] Setting Jump Code Procedure in A Function Code. Jump to code A-12 from A-00.

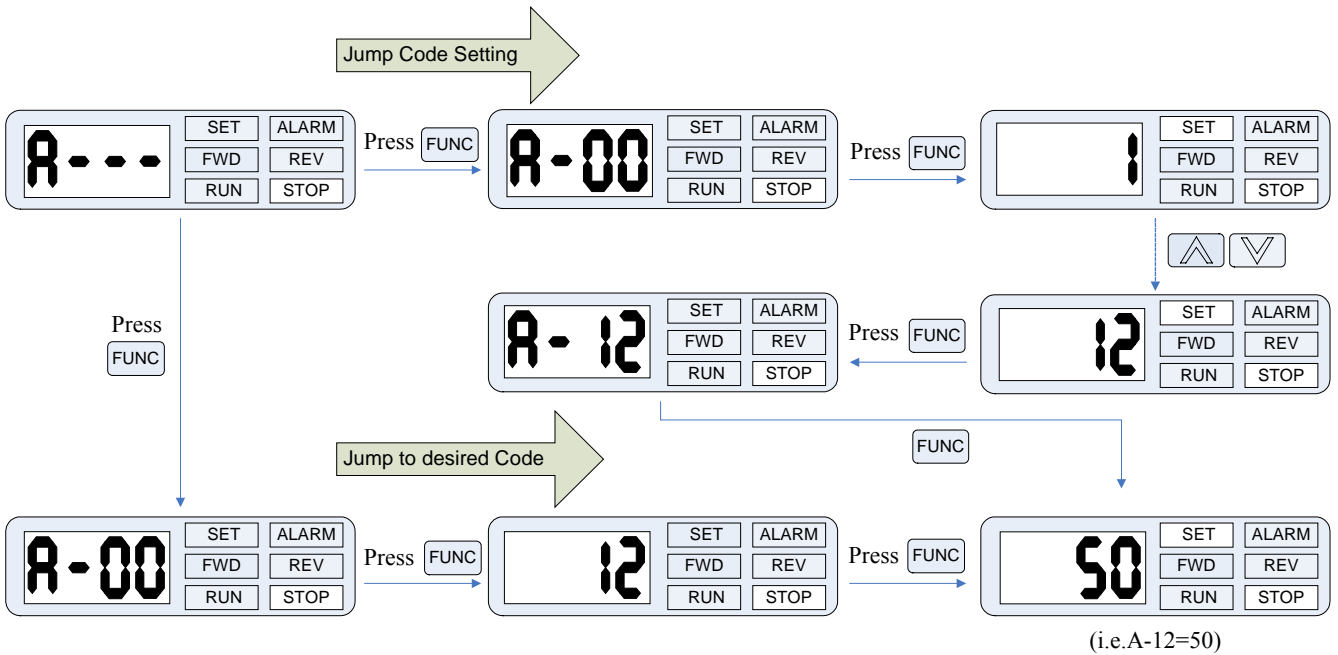

---

## Constant Group

The EI-500 series offers 4 Function Groups. The group's names and the description are as bellow :

	<b>Group Name</b>	<b>Description</b>
Function Group U	(Drive Group)	Frequency Command, Accel/ Decel Time, etc.
Function Group A	(Standard Group)	Max. Frequency, Torque Boost, etc.
Function Group b	(Application Group)	Frequency Jump, Frequency Limit, etc.
Function Group C	(Multi-function Terminal Group)	Multi-function terminal setting and sequence operation constants



Refer to the parameter description in Chapter 4 for detailed description of each group.

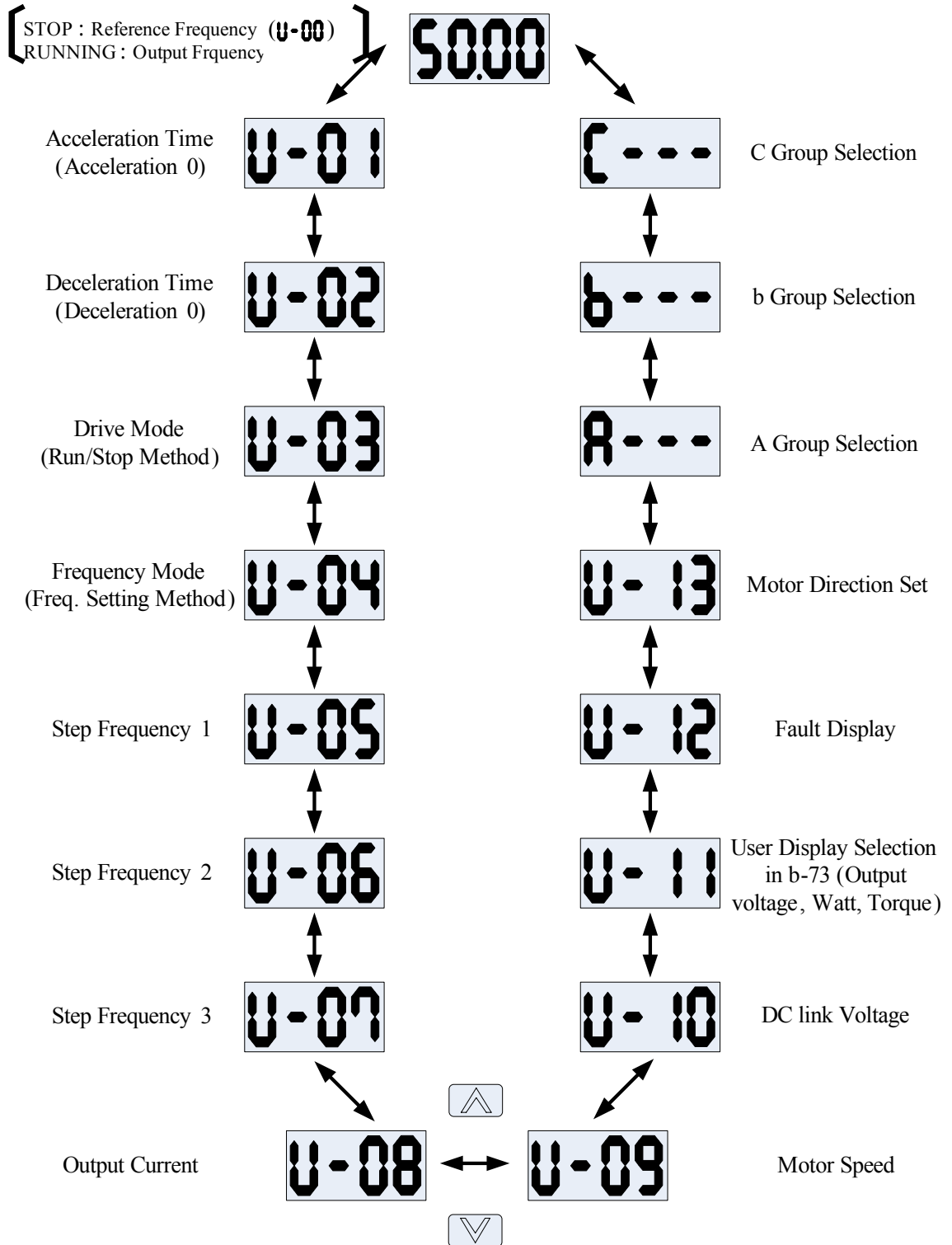

■ Moving through U Group Codes











---

## Test Run

〔 Operation Reference :  key,  key of Digital Operator 〕 ( Factory Default )  
Frequency Reference : Potentiometer of Digital Operator

1. Turn the power ON and set U-03=0, U-04=1. (Factory Default)
2. Press  key. LED **RUN** and **FOR (REV)** will lit, **STOP** will lit.
3. Adjust potentiometer of digital operator to change motor speed.
4. Press  key for the motor to coast to stop. The LED of **RUN** and **FOR (REV)** will turn OFF and **STOP** will turn ON.

〔 Operation Reference :  key,  key of Digital Operator 〕  
Frequency Reference :  key,  key of Digital Operator



1. Turn the power ON and set U-03=0, U-04=0.
2. (Return 7-segment display to U-00.) Use  key,  key,  key to set the operation frequency value. (It displays the set frequency value at stop.)
3. Press RUN key, the motor will start running. The output frequency is show on the digital operator at the same time.
4. Press  key, the motor will decrease to stop. In the meantime, the frequency value appears on the digital operator.

〔 Operation Reference : External Terminal (Terminal S1, S2) 〕  
Frequency Reference : External Terminal (Terminal Vs or Is)

1. Turn the power of motor ON and set U-03=1, U-04=2.
2. Have the external potentiometer connect to terminal +12V, Vs, COM to adjust the value of potentiometer. The digital operator displays the frequency value.
3. To make the motor forward run, the terminal S1 and COM need to be closed.
4. Have the terminal S1 to be opened and terminal S2 and COM to be closed so that the motor does reverse run.
5. The motor decreases to stop when terminal S2 is opened. The digital operator displays the frequency value set by external potentiometer.

## CHAPTER 3 CONSTANTS LIST

### Function Group U (Drive Group)

Code	Description	Setting Range	Units	Factory Default	Adj. During Run	Ref. Page
U-00	Reference Frequency during stop Output Frequency during running	0.00 to Max. output frequency (A-20)	0.01	00.00 [Hz]	Yes	31
U-01	Acceleration Time	0.0 to 999.9 [sec]	0.1	10.0 [sec]	Yes	31
U-02	Deceleration Time	0.0 to 999.9 [sec]	0.1	20.0 [sec]	Yes	31
U-03	Drive Mode (Run/Stop Method)	0 (Digital Operator)	-	0	No	32
		1 External Terminal Pattern 1 (S1/S2-1)				
		2 External Terminal Pattern 2 (S1/S2-2)				
		3 (RS485)				
U-04	Frequency Mode (Freq. Setting Method)	0   key of RCU-500 (U-00)	-	1	No	33
		1 Potentiometer of RCU-500				
		2 External Terminal (Vs)				
		3 External Terminal (Is)				
		4 External Terminal (Vs+Is)				
5 (RS485) Communication Port						
U-05	Step Frequency 1	0.00 to Max. Frequency(A-20)	0.01	10.00 [Hz]	Yes	35
U-06	Step Frequency 2			20.00 [Hz]		
U-07	Step Frequency 3			30.00 [Hz]		
U-08	Output Current	-	[A]	-	-	36
U-09	Motor Speed	-	[rpm]	-	-	36
U-10	DC link Voltage	-	[V]	-	-	36
U-11	b-73 Selection Display	0 : Inverter Output Voltage	-	-	-	37
		1 : Inverter Output Watt				
		2 : Inverter Output Torque				
U-12	Fault Display	-	-	0	-	37
U-13	Motor Direction Set	F (Forward)	-	F (Forward)	Yes	38
		r (Reverse)				
A- - -	A Group Selection					38
b- - -	b Group Selection					38
C- - -	C Group Selection					38

## Function Group A (Standard Group)

Code	Description	Setting Range	Units	Factory Default	Adj. During Run	Ref. Page
A-00	Jump to Desired Code #	1 to 99	1	3	Yes	39
A-03	Run Prevention	0 (None)	-	0	No	39
		1 (Forward Prev)				
		2 (Reverse Prev)				
A-05	Acceleration Pattern	0 (Linear)	-	0	No	39
		1 (S-Curve)				
		2 (U-Curve)				
		3 (Minimum)				
		4 (Optimum)				
A-06	Deceleration Pattern	0 (Linear)	-	0	No	39
		1 (S-Curve)				
		2 (U-Curve)				
		3 (Minimum)				
		4 (Optimum)				
A-07	Stop Mode	0 (Decel)	-	0	No	41
		1 (DC-brake)				
		2 (Free-run)				
A-08	DC Injection Braking Frequency	A-22 to 50/60 [Hz]	0.01	5.00 [Hz]	No	43
A-09	DC Injection Braking ON-DELAY Time	0 to 60 [sec]	0.01	0.10 [sec]	No	
A-10	DC Injection Braking Voltage	0 to 200 [%]	1	50 [%]	No	
A-11	DC Injection Braking Time	0 to 60 [sec]	0.1	1.0 [sec]	No	
A-12	Starting DC Injection Braking Voltage	0 to 200 [%]	1	50 [%]	No	44
A-13	Starting DC Injection Braking Time	0 to 60 [sec]	0.1	0.0 [sec]	No	
A-20	Maximum Output Frequency	40 to 400 [Hz]	0.01	50 / 60 [Hz]	No	45
A-21	Maximum Voltage Output Frequency	30 to (A-20)	0.01	50 / 60 [Hz]	No	
A-22	Minimum Output Frequency	0.1 to 10 [Hz]	0.01	0.10 [Hz]	No	
A-23	Frequency Limit Selection	0 (No)	-	0	No	45
		1 (Yes)				
A-24	Low Limit Frequency	A-22 to A-25	0.01	0.00 [Hz]	No	
A-25	High Limit Frequency	A-24 to A-20	0.01	50 / 60 [Hz]	No	
A-26	Manual/Auto Torque Boost Selection	0 (Manual)	-	Manual 0	No	46
		1 (Auto)				
A-27	Manual - Torque Boost in Forward Direction	0.0 to 15.0 [%]	0.1	2.0 [%]	No	
A-28	Manual - Torque Boost in Reverse Direction		0.1	2.0 [%]	No	

Code A-08, A-09, A-11 appears only when A-07=1.

Code A-24, A-25 appears only when A-23=1.

Code	Description	Setting Range	Units	Factory Default	Adj. During Run	Ref. Page	
A-29	Volts/Hz Pattern	0 (Linear)	-	0	No	47	
		1 (Square)					
		2 (User V/F)					
A-30	User V/F – Frequency 1	0.00 ~ A-32	0.01	15.00 [Hz]	No	48	
A-31	User V/F – Voltage 1	0 to 100 [%]	1	25 [%]	No		
A-32	User V/F – Frequency 2	A-30 to A-34	0.01	30.00 [Hz]	No		
A-33	User V/F – Voltage 2	0 to 100 [%]	1	50 [%]	No		
A-34	User V/F – Frequency 3	A-32 to A-36	0.01	45.00 [Hz]	No		
A-35	User V/F – Voltage 3	0 to 100 [%]	1	75 [%]	No		
A-36	User V/F – Frequency 4	A-34 to A-20	0.01	50 / 60 [Hz]	No		
A-37	User V/F – Voltage 4	0 to 100 [%]	1	100 [%]	No		
A-38	Maximum Output Voltage	40 to 110 [%]	0.1	100.0 [%]	No	48	
A-39	Energy Save Level	0 to 30 [%]	1	0 [%]	Yes	49	
A-50	Electronic Thermal Selection	0 (No)	-	0	Yes	50	
		1 (Yes)					
A-51	Electronic Thermal Level for 1 Minute	A-52 to 250 [%]	1	180 [%]	Yes		
A-52	Electronic Thermal Level for Continuous	50 to A-51	1	120 [%]	Yes		
A-53	Electronic Thermal Characteristic Selection (Motor type)	0 (Self-cooling)	-	0	Yes		
		1 (Forced-cooling)					
A-54	Overload Warning Level	30 to 250 [%]	1	150 [%]	Yes		51
A-55	Overload Warning Hold Time	0 to 30 [sec]	0.1	10.0 [sec]	Yes		
A-56	Overload Trip Selection	0 (No)	-	1	Yes	52	
		1 (Yes)					
A-57	Overload Trip Level	30 to 250 [%]	1	200 [%]	Yes		
A-58	Overload Trip Delay Time	0 to 60 [sec]	1	60.0 [sec]	Yes		
A-59	Stall Prevention Mode Selection	000 – 111 (bit set) Bit 0 : during Accel. Bit 1 : during Steady speed Bit 2 : during Decel.	bit	000	No	53	
A-60	Stall Prevention Level	30 to 250 [%]	1	200 [%]	No		
A-99	Return to A Group		-	-	-	55	

Code A-30 ~ A-37 appears only when A-29 = 2.

Code A-51 ~ A-53 appears only when A-50 = 1.

Code A-57 ~ A-58 appears only when A-56 = 1.

## Function Group b (Application Group)

Code	Description	Setting Range	Units	Factory Default	Adj. During Run	Ref. Page
b-00	Jump to Desired Code #	1 to 99	1	1	Yes	56
b-01	Previous Fault History 1		-	0	-	56
b-02	Previous Fault History 2					
b-03	Previous Fault History 3					
b-04	Previous Fault History 4					
b-05	Previous Fault History 5					
b-06	Erase Fault History	0 (No) 1 (Yes)	-	No 0	Yes	
b-07	Dwell Frequency	0 to A-20	0.01	5.00 [Hz]	No	57
b-08	Dwell Time	0 to 10 [sec]	0.1	0.0 [sec]	No	
b-10	Frequency Jump Selection	0 (No) 1 (Yes)	-	No 0	No	58
b-11	Jump Frequency 1 Low	0.00 to b-12	0.01	0.00 [Hz]	No	
b-12	Jump Frequency 1 High	b-11 to A-20	0.01	0.00 [Hz]	No	
b-13	Jump Frequency 2 Low	0.00 to b-14	0.01	0.00 [Hz]	No	
b-14	Jump Frequency 2 High	b-13 to A-20	0.01	0.00 [Hz]	No	
b-15	Jump Frequency 3 Low	0.00 to b-16	0.01	0.00 [Hz]	No	
b-16	Jump Frequency 3 High	b-15 to A-20	0.01	0.00 [Hz]	No	
b-19	Input/Output Phase Loss Protection	00 – 11 (bit set) Bit 0 : Output Phase Loss Protection Bit 1 : Input Phase Loss Protection	-	00	Yes	58
b-20	Power ON Start Selection	0 (No) 1 (Yes)	-	No 0	Yes	59
b-21	Restart after Fault Reset	0 (No) 1 (Yes)	-	No 0	Yes	59
b-22	Speed Search Selection	0000 – 1111 (bit set) Bit 0 : During Accel. Bit 1 : After Fault reset Bit 2 : After Instant Power Failure restart Bit 3 : When b-20 is set to 1 (Yes).	-	0000	No	60
b-23	Current Limit Level During Speed Search	80 to 250 [%]	1	180 [%]	Yes	60
b-24	P Gain During Speed Search	0 to 9999	1	100	Yes	60
b-25	I Gain During speed search	0 to 9999	1	5000	Yes	60
b-26	Number of Auto Restart Attempt	0 to 10	1	0	Yes	62
b-27	Delay Time before Auto Restart	0 to 60 [sec]	0.1	1.0 [sec]	Yes	

Code b-11~b-6 appears only when b-10=1.

Code	Description	Setting Range	Units	Factory Default	Adj. During Run	Ref. Page
b-30	Rated Motor Selection	0.8 (0.75kW)	-		No	62
		1.5 (1.5kW)				
		2.2 (2.2kW)				
		3.7 (3.7kW)				
b-31	Motor Pole	2 to 12	1	4	No	63
b-32	Rated Motor Slip	0 to 10 [Hz]	0.01		No	
b-33	Rated Motor Current in RMS	0.1 to 99.9 [A]	1		No	
b-34	No Load Motor Current in RMS	0.1 to 99.9 [A]	1		No	
b-36	Motor Efficiency	5 0 to 100 [%]	1		No	
b-37	Load Inertia	0 to 2	1	0	No	
b-39	Carrier Frequency	1 to 10 [kHz]	1	3 [kHz]	Yes	63
b-40	Control Mode Selection	0 (V/F)	-	V/F 0	No	64
		1 (Slip Compensation)				
		2 (PID)				
b-50	PID Feedback Signal Selection	0 (Is)	-	Is 0	No	65
		1 (Vs)				
b-51	P Gain for PID Control	0 to 9999	1	3000	Yes	
b-52	I Gain for PID Control	0 to 9999	1	300	Yes	
b-53	D Gain for PID Control	0 to 9999	1	0	Yes	
b-54	Limit Frequency for PID Control	0 to A-20	0.01	50 / 60 [Hz]	Yes	
b-70	Reference Frequency for Accel and Decel	0 (Max. Freq.)	-	Max frq 0	No	66
		1 (Delta Freq.)				
b-71	Accel/Decel Time Scale	0 (0.01 sec)	-	0.1 sec 1	Yes	66
		1 (0.1 sec)				
		2 (1 sec)				
b-72	Power On Display for parameter code from U-00 ~ U-13.	0 (Reference Frequency)	1	0	Yes	67
		1 (Acceleration Time)				
		2 (Deceleration Time)				
		3 (Drive Command)				
		4 (Freq. Command)				
		5 (Step Freq 1)				
		6 (Step Freq 2)				
		7 (Step Freq 3)				
		8 (Output Current)				
		9 (Motor Speed)				
		10 (DC Link Voltage)				
		11 (b-73 Selection Display)				
		12 (Fault Display)				
13 (Motor Direction Setting)						
b-73	U-11 Selection Display	0 (Inverter Output Voltage)	-	Voltage 0	Yes	67
		1 (Inverter Output Watt)				
		2 (Inverter Output Torque)				
b-74	Gain for Motor Speed Display	1 to 1000 [%]	1	100 [%]	Yes	68

Code b-34 appears only when b-40=1

Code b-50 to b-54 appears only when b-40=2.

Code	Description	Setting Range	Units	Factory Default	Adj. During Run	Ref. Page
b-75	DB (Dynamic Braking) Resistor Mode Selection	0 (None)	-	2	Yes	68
		1 (None)				
		2 (Ext. DB-R)				
b-76	Duty of Dynamic Braking Resistor	0 to 30 [%]	1	10 [%]	Yes	68
b-79	Software Version	x.xx	-	-	-	69
b-81	2 <sup>nd</sup> Acceleration Time	0.0 to 999.9 [sec]	0.1	5.0 [sec]	Yes	69
b-82	2 <sup>nd</sup> Deceleration Time	0.0 to 999.9 [sec]	0.1	10.0 [sec]	Yes	
b-83	2 <sup>nd</sup> Base Frequency	30 to A-20	0.01	50 / 60 [Hz]	No	
b-84	2 <sup>nd</sup> V/F Pattern	0 (Linear)	-	Linear 0	No	
		1 (Square)				
		2 (User V/F)				
b-85	2 <sup>nd</sup> Forward Torque Boost	0 to 15 [%]	0.1	2.0 [%]	No	
b-86	2 <sup>nd</sup> Reverse Torque Boost	0 to 15 [%]	0.1	2.0 [%]	No	
b-87	2 <sup>nd</sup> Stall Prevention Level	30 to 250 [%]	1	200[%]	No	
b-88	2 <sup>nd</sup> Electronic Thermal Level for 1 Minute	b-89 to 250 [%]	1	180 [%]	Yes	
b-89	2 <sup>nd</sup> Electronic Thermal Level for Continuous	50 to (b-88)	1	120 [%]	Yes	
b-90	2 <sup>nd</sup> Rated Motor Current	0.1 to 99.9 [A]	0.1	-[A]	No	
b-91	Read Parameters into potentiometer of digital operator (RCU-500) from Inverter	0 (No)	-	No 0	No	70
		1 (Yes)				
b-92	Write Parameters to Inverter from potentiometer of digital operator (RCU-500)	0 (No)	-	No 0	No	70
		1 (Yes)				
b-93	Initialize Parameters	0 (No)	-	No 0	No	70
		1 (All Groups)				
		2 (U Groups)				
		3 (A Groups)				
		4 (b Groups)				
5 (C Groups)						
b-94	Parameter Write Protection	0 to 255	1	0	Yes	71
b-99	Return Code		-	-	Yes	71

Code b-81 to b-90 appears only when C-12=7 or C-13=7 or C-14=7.

Code b-94 : To avoid any accident happening when other user change the constant value, this function is used to lock the constant value from being changed or entering the constant value. RCU-500 shows “L - - O” after the constant is settled in b-94=6 which means the code cannot be adjusted. If the b-94=6 have been reset, then RCU-500 shows “U - - O” to be adjustable, then the constant value can be set.

## Function Group C (Multi-function Terminal Group)

Code	Description	Setting Range	Units	Factory Default	Adj. During Run	Ref. Page
C-00	Jump to Desired Code #	1 to 99	1	1	Yes	72
C-01	Filtering Time Constant for Vs Signal Input	0 to 9999 [ms]	1	100 [ms]	Yes	72
C-02	Vs Input Minimum Voltage	0 to C-04 [V]	0.01	0.00 [V]	Yes	
C-03	Frequency corresponding to Vs Input Minimum Voltage	0 to A-20	0.01	0.00 [Hz]	Yes	
C-04	Vs Input Maximum Voltage	C-02 to 12.00 [V]	0.01	10.00 [V]	Yes	
C-05	Frequency corresponding to Vs Input Maximum Voltage	0.00 to A-20	0.01	50 / 60 [Hz]	Yes	
C-06	Filtering Time Constant for Is Signal Input	0 to 9,999 [ms]	1	100 [ms]	Yes	72
C-07	Is Input Minimum Current	0.00 to C-09	0.01	4.00 [mA]	Yes	
C-08	Frequency corresponding to Is Input Minimum Current	0.00 to A-20	0.01	0.00 [Hz]	Yes	
C-09	Is Input Maximum Current	C-07 to 24.00[mA]	0.01	20.00 [mA]	Yes	
C-10	Frequency corresponding to Is Input Maximum Current	0.00 to (A-20)	0.01	50 /60 [Hz]	Yes	
C-11	Criteria for Analog Input Signal Loss	0 (None) 1 (Half of x1) 2 (Below x1)	-	No 0	Yes	73
C-12	Multi-function Input Terminal "S6" Define 8, 15, 17, 20, 21, 22, 23, 24, 25, 26 (-Reserved-)	0 (Speed-L) 1 (Speed-M) 2 (Speed-H) 3 (XCEL-L) 4 (XCEL-M) 5 (XCEL-H) 6 (Dc-brake) 7 (2nd Function) 9 (Vs-Ext) 10 (Up) 11 (Down) 12 (3-Wire) 13 (Ext Trip-A) 14 (Ext Trip-B) 16 (Open-Loop) 18 (Analog Hold) 19 (XCEL Stop)	-	Speed-L 0	No	74
C-13	Multi-function Input Terminal "S7" Define	Same as above C-12	-	Speed-M 1	No	75
C-14	Multi-function Input Terminal "S8" Define	Same as above C-12	-	Speed-H 2	No	
C-15	Terminal Input Status	00000000 – 11111111 (bit set)	-	-	-	81
C-16	Terminal Output Status of M1-M2 Multi-function	0 – 1 (bit set)	-	0	-	
C-17	Filtering Time Constant for Multi-function Input Terminals	2 to 50	1	2	Yes	81

Code	Description	Setting Range	Units	Factory Default	Adj. During Run	Ref. Page
C-20	Jog Frequency Setting	0.00 to A-20	0.01	10.00 [Hz]	Yes	81
C-21	Step Frequency 4	0.00 to A-20		40.00 [Hz]	Yes	82
C-22	Step Frequency 5	0.00 to A-20		50.00 [Hz]	Yes	
C-23	Step Frequency 6	0.00 to A-20		40.00 [Hz]	Yes	
C-24	Step Frequency 7	0.00 to A-20		30.00 [Hz]	Yes	
C-25	Acceleration Time 1 for Step Frequency	0.0 to 999.9 [sec]	0.1	20.0 [sec]	Yes	82
C-26	Deceleration Time 1 for Step Frequency	0.0 to 999.9 [sec]	0.1	20.0 [sec]	Yes	
C-27	Acceleration Time 2	0.0 to 999.9 [sec]	0.1	30.0 [sec]	Yes	
C-28	Deceleration Time 2	0.0 to 999.9 [sec]	0.1	30.0 [sec]	Yes	
C-29	Acceleration Time 3	0.0 to 999.9 [sec]	0.1	40.0 [sec]	Yes	
C-30	Deceleration Time 3	0.0 to 999.9 [sec]	0.1	40.0 [sec]	Yes	
C-31	Acceleration Time 4	0.0 to 999.9 [sec]	0.1	50.0 [sec]	Yes	
C-32	Deceleration Time 4	0.0 to 999.9 [sec]	0.1	50.0 [sec]	Yes	
C-33	Acceleration Time 5	0.0 to 999.9 [sec]	0.1	40.0 [sec]	Yes	
C-34	Deceleration Time 5	0.0 to 999.9 [sec]	0.1	40.0 [sec]	Yes	
C-35	Acceleration Time 6	0.0 to 999.9 [sec]	0.1	30.0 [sec]	Yes	
C-36	Deceleration Time 6	0.0 to 999.9 [sec]	0.1	30.0 [sec]	Yes	
C-37	Acceleration Time 7	0.0 to 999.9 [sec]	0.1	20.0 [sec]	Yes	
C-38	Deceleration Time 7	0.0 to 999.9 [sec]	0.1	20.0 [sec]	Yes	
C-40	FM-FC (Frequency Meter) Output Selection	0 (Frequency)	-	Frequency 0	Yes	82
		1 (Current)				
		2 (Voltage)				
		3 (DC Link Voltage)				
C-41	FM-FC Output Adjustment	10 to 200 [%]	1	100 [%]	Yes	
C-42	Frequency Detection Level	0 to A-20	0.01	30.00 [Hz]	Yes	83
C-43	Frequency Detection Bandwidth	0 to A-20	0.01	10.00 [Hz]	Yes	
C-44	Multi-function Output Define M1 - M2 Selection 15, 16, 18, 19 (-Reserved-)	0 (FDT-1)	-	12 (Run)	Yes	83
		1 (FDT-2)				
		2 (FDT-3)				
		3 (FDT-4)				
		4 (FDT-5)				
		5 (OL1)				
		6 (OL2)				
		7 (Stall)				
		8 (OV)				
		9 (UV)				
		10 (OH)				
		11 (Lost Command)				
		12 (Run)				
		13 (Stop)				
		14 (Steady)				
		17 (Search)				
20 (Ready)						

Code	Description	Setting Range	Units	Factory Default	Adj. During Run	Ref. Page
C-45	Fault Output Relay Terminal Selection (MA, MB, MC)	000 – 111 (bit set) Bit 0 : LV Bit 1 : All Trip Bit 2 : Auto Retry	-	010	Yes	90
C-46	Communication Code Setting	1 to 32	1	1	Yes	90
C-47	Baud Rate	0 (1200 bps)	-	9600 bps 3	Yes	
		1 (2400 bps)				
		2 (4800 bps)				
		3 (9600 bps)				
4 (19200 bps)						
C-48	Operating selection at Loss of Freq. Reference	0 (None)	-	None 0	Yes	
		1 (Free Run)				
		2 (Stop)				
C-49	Waiting Time after Loss of Freq. Reference	0.1 to 120.0 [sec]	0.1	1.0 [sec]	Yes	90
C-99	Return Code		-	1	Yes	91

Note : Parameters that are set displayed in bit (A-59, b-19, b-22, C-15, C-16, C-45 are the parameters that displayed in bit.)

Example) when the digital operator displays “00000011”

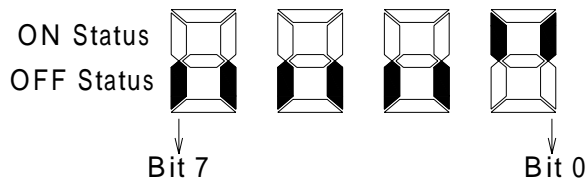



---

## CHAPTER 4 CONSTANT

### Function Group U (Drive Group)

#### U-00 : Output Frequency

U-00 is used to display the message of reference frequency during stop or to displays the output frequency during running. It also can be set by U-13 to determine the desired direction of the motor. (Forward Run or Reverse Run).

User can use potentiometer of digital operator to set the frequency reference (U-04=1). It also can be done by pressing   keys.

#### Related Constants :

U-04 [Frequency Mode] : Select the frequency setting methods (Digital operator-1, digital operator-2, terminal Vs, terminal Is, terminal Vs+Is, RS485 communication port.)

A-20 [Max. Output Frequency]

C-01 to C-10 [Analog Reference Inputs] : Scaling the analog input signals (Vs and Is) for frequency reference and potentiometer of digital operator.

#### U-01 : Acceleration Time

#### U-02 : Deceleration Time

The reference frequency for accel/ decel is determined by b-70 when accelerating or decelerating.

If b-70 is set to “Maximum Frequency”, the acceleration time is the time taken by the motor to reach A-20 [Maximum Output Frequency] from 0 Hz. The deceleration time is the time taken by the motor to reach 0 Hz to A-20 [Maximum Output Frequency].

When b-70 is set to “Delta Frequency”, the acceleration and deceleration time is the time taken to reach targeted frequency (instead of the maximum frequency) from current frequency.

The acceleration and deceleration time can be selected to preset step acceleration/ deceleration time via multi-function input terminal. Set the multi-function inputs (S6, S7, S8) to “XCEL-L”, “XCEL-M”, “XCEL-H” respectively. The step acceleration/ deceleration time can be set in C-25 to C-38 according to the binary inputs of the S6, S7, S8.

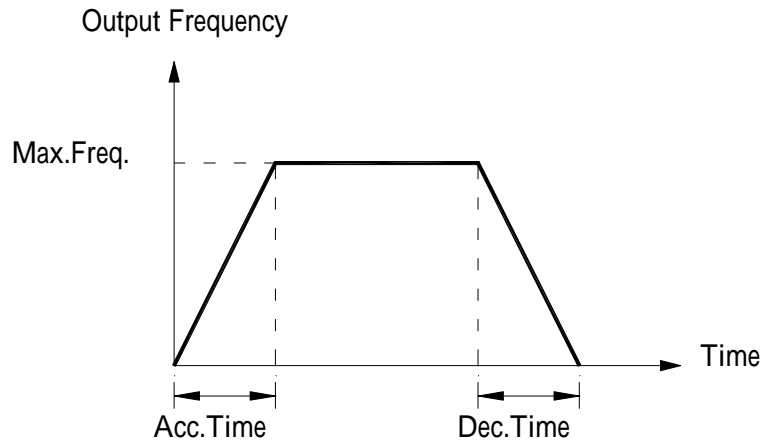

**Related Constants :**

A-20 [Max. Output Freq]

b-70 [Reference Freq. for Accel/Decel]

b-71 [Accel/Decel Time Scale]

C-12 to C-14 : [Multi-function Input Terminal S6, S7, S8]

C-25 to C-38 : Select the Step accel/ decel time in C-25 to C-38 by terminal S6, S7, S8.

**U-03 : Drive Mode (Run/stop Method)**

Setting Range		Description
Select	Display	
<b>U-03</b>	0 (Factory Default)	Run/ stop is controlled by <input type="button" value="RUN"/> , <input type="button" value="STOP&lt;br/&gt;RESET"/> keys of digital operator.
	1	Run/ stop is controlled by control terminals S1, S2 and terminal COM for S1/S2-1 pattern.
	2	Run/ stop is controlled by control terminals S1, S2 and terminal COM for S1/ S2-2 pattern.
	3	Run/ stop is controlled by RS485communication port, MODBUS-RTU communication format.

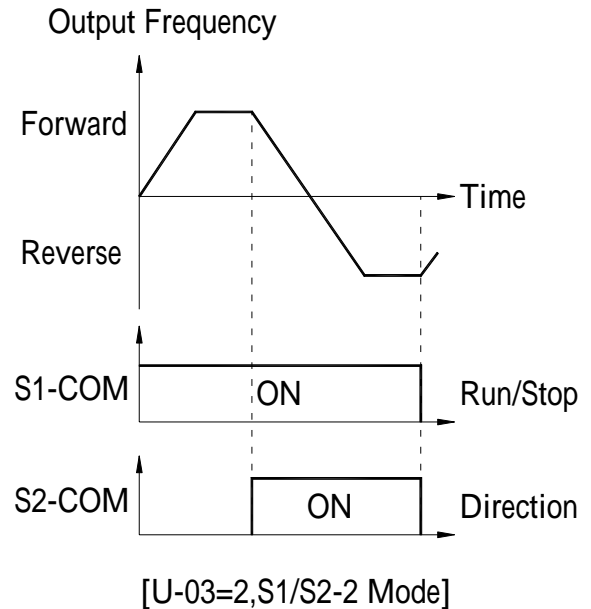
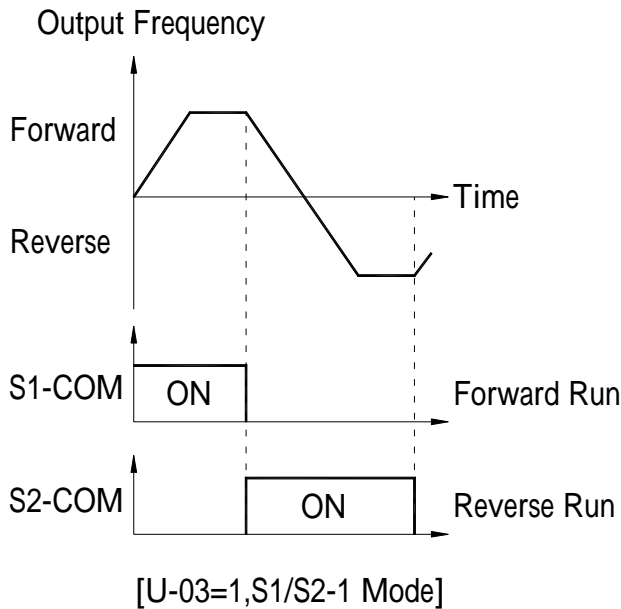

**U-04 : Frequency Mode (Frequency Setting Method)**

Select the source of frequency setting.

Setting Range		Description
Select	Display	
<b>U-04</b>	0 (Digital Operator-1)	Frequency reference is set by pressing   keys of digital operator. Press  key to store the setting value in U-00. The inverter does not change the output frequency value before pressing  key.
	1 (Digital Operator-2) (Factory Default)	Frequency reference is set by potentiometer of digital operator. Refer to C-01 to C-05 for scaling the potentiometer single.
	2 (Vs)	Input the frequency reference 0~+10V by external terminal Vs. Refer to C-01 to C-05 for scaling the terminal Vs signal.
	3 (Is)	Input the frequency reference (4~20mA) by external terminal Is. Refer to C-06 to C-10 for scaling the terminal Is signal.
	4 (Vs+Is)	Input the frequency reference (0~10V, 4~20mA) to the terminal Vs, Is at the same time. The signal Vs overwrites the signal Is. (Signal Vs plus signal Is)
	5 (RS-485)	Run/ stop is controlled by RS485 communication port, MODBUS-RTU communication format.

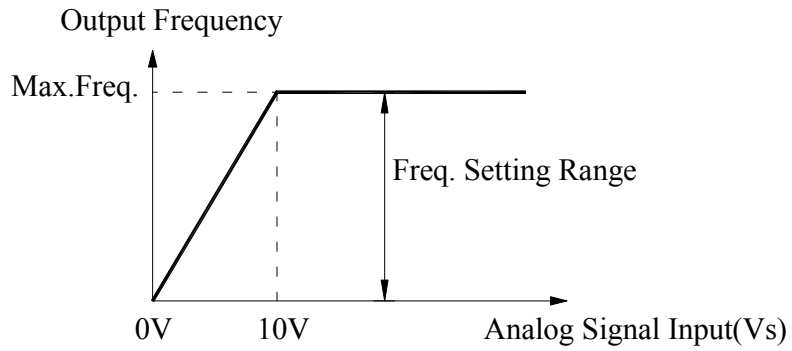

[U-04=2  $V_s$  Mode]

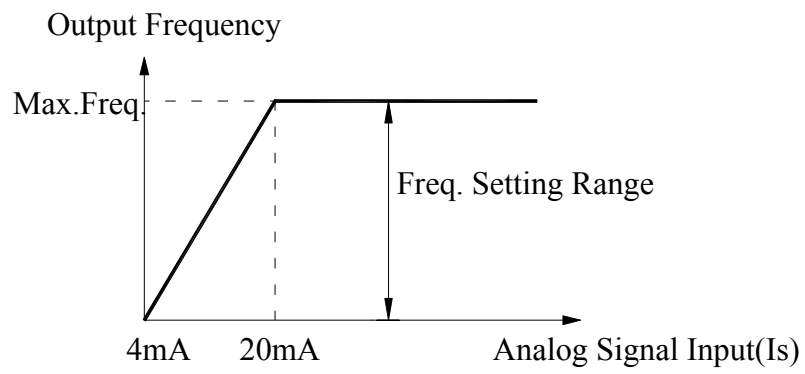

[U-04=3  $I_s$  Mode]

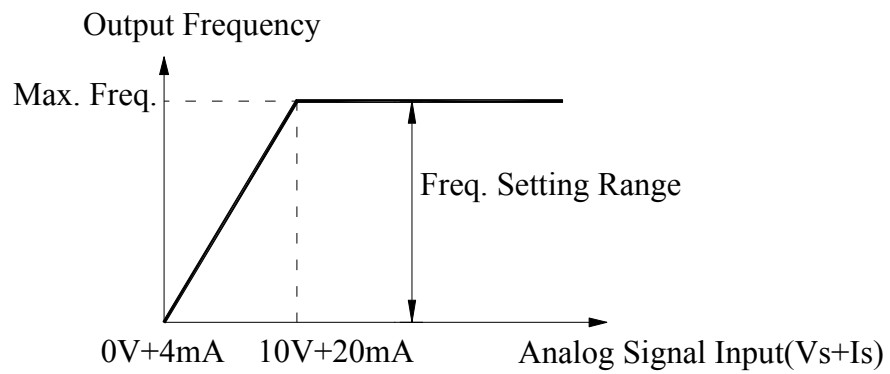

[U-04=4  $V_s+I_s$  Mode]

U-05 : Step Frequency 1  
 U-06 : Step Frequency 2  
 U-07 : Step Frequency 3

Binary Combination of multi-function terminal S6, S7, S8			The signal source from frequency reference.	Description
Terminal S6-COM	Terminal S7-COM	Terminal S8-COM		
Speed-L	Speed-M	Speed-H		
C-12=0	C-13=1	C-14=2		
0 (off)	0 (off)	0 (off)	<b>U-04</b>	Select frequency reference. (Speed 0)
1 (on)	0 (off)	0 (off)	<b>U-05</b>	Frequency reference 1
0 (off)	1 (on)	0 (off)	<b>U-06</b>	Frequency reference 2
1 (on)	1 (on)	0 (off)	<b>U-07</b>	Frequency reference 3
0 (off)	0 (off)	1 (on)	<b>C-21</b>	Frequency reference 4
1 (on)	0 (off)	1 (on)	<b>C-22</b>	Frequency reference 5
0 (off)	1 (on)	1 (on)	<b>C-23</b>	Frequency reference 6
1 (on)	1 (on)	1 (on)	<b>C-24</b>	Frequency reference 7

**Related Constants :**

C-12 to C-14 [Select the multi-function input terminal S6, S7, S8]

C-17 [Filtering Time Constant for multi-function input terminal] : Adjust the filtering time of input terminal to eliminate contact noise.

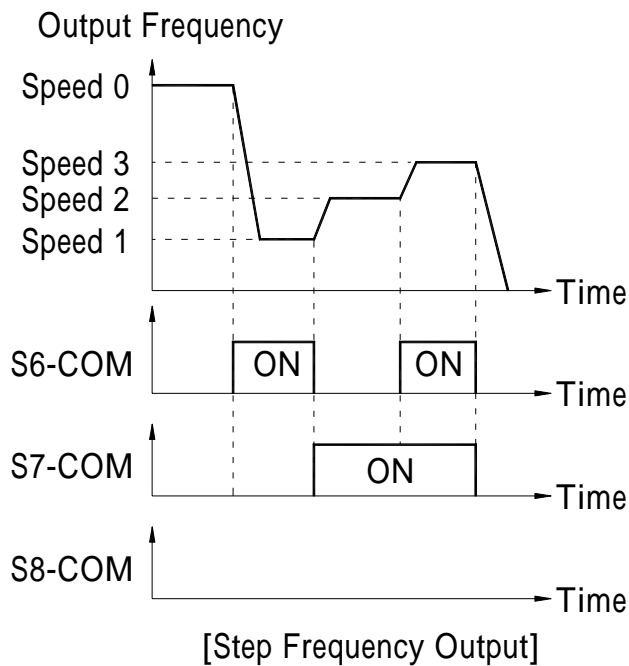

**U-08 : Output Current**

U-08 displays the output current of the inverter in RMS.

**U-09 : Motor Speed**

U-09 displays the motor speed in RPM when the motor is running. Adjust the setting value of b-74[Gain for motor speed display]. The meaning of display value can be changed. (Example : r/min or m/min)

$$\text{Motor constant rotation} = \frac{120 \times F}{P} \times \text{Constant b-74}$$

F : Output frequency

P : The number of motor poles (Constant b-31)

b-74 : Adjust the gain of motor speed display.

**U-10 : DC Link Voltage**

U-10 displays the DC link voltage inside the inverter.

## U-11 : b-73 Selection Display



There are 3 types of constant in b-73 as bellow :

b-73=0 displays the inverter output voltage (Factory Default)

b-73=1 displays the inverter output watt.

b-73=2 displays the inverter output torque.

## U-12 : Fault Display

U-12 displays the current fault (trip) status of the inverter. Use the  key,  key and  key to check the fault contents(s), output frequency fault, output current trip, or whether the inverter is accelerating, decelerating, or in constant speed at the time the fault occurs.

The fault content(s) will be auto-stored in b-01 to b-05 when the  key is pressed. Refer to Chapter 5 – Troubleshooting & Maintenance for detail content(s).

Display of digital operator	Fault Status (Trip)	
<b>OC</b>	Over current	
<b>OV</b>	Over voltage	
<b>UV</b>	Under voltage	
<b>OH</b>	Heat sink overheat	
<b>ETH</b>	Electronic thermal trip	
<b>OL1</b>	Motor overload	
<b>OL2</b>	Inverter overload	
<b>PF</b>	Inverter input phase loss	
<b>LF</b>	Inverter output phase loss	
<b>EF1</b>	Emergency stop (Terminal S3 closed.)	
<b>CPFS</b> Inverter hardware fault	<b>CPF3</b>	CPU EEPROM error
	<b>FAn</b>	Inverter cooling fan fault
	<b>CPF4</b>	CPU error
	<b>GF</b>	Ground Fault
	<b>ntC</b>	NTC damage

The inverter will not reset when CPF5 fault (Inverter hardware fault) occurs. Repair the fault before turning on the power.

### Related Constants :

b-01 to b-05 [Fault History up to 5]

b-06 [Erase Fault History]

---

U-13 : Motor Direction Set

7-segment Display	Description
F	Forward Run Direction
r	Reverse Run Direction

A--- : A Group selection

b--- : b Group selection

C--- : C Group selection

## Function Group A (Standard Group)

### A-00 : Jump to Desired Code #

Jumping directly to any constant(s) code can be accomplished by entering the desired function group A.

### A-03 : Run Prevention

This function prevents reverse run of the motor. This function may be used for loads that rotate only in one direction such as mills and pumps.

Constant Code		Description
<b>A-03</b>	0 None	Forward and reverse run is available.
	1 Forward Prohibition	Forward run is prohibited.
	2 Reverse Prohibition	Reverse run is prohibited.

### A-05 : Acceleration Pattern

### A-06 : Deceleration Pattern

Different combinations of acceleration and deceleration patterns can be selected according to different applications.

Constant Code		Description
<b>A-05</b>  <b>A-06</b>	0 (Factory Default) Linear	This is a general pattern for fixed torque control output.
	1 S-Curve	This pattern allows the motor to accelerate and decelerate smoothly. The actual acceleration and deceleration time is longer about 40% than the time set in U-01 and U-02.
	2 U-Curve	This pattern provides more efficient control of accel/ decel in typical winding machine application.
	3 Minimum	The inverter reduces acceleration time by accelerating with its 150% rated current and reduces deceleration time by decelerating with a DC 95% voltage rate of of its over-voltage trip level. Appropriate application : To make max. output capacity of inverter and motor. Inappropriate application : The current limit function may extend the time for loads that have high inertia such as mills.
4 Optimum	The inverter accelerates with current rate of 120% of its rated current and decelerates with voltage rate of 93% of its over-voltage trip level.	

---

**NOTE :**

1. When selecting the “Minimum” or “Optimum”, the U-01 [Accel Time] and U-02 [Decel Time] is ignored.
2. “Minimum” and “Optimum” functions can be operated when the load inertia is less than 10 times the motor inertia. (b-37)
3. “Optimum” is best effective when the motor capacity is smaller than inverter capacity.
4. “Minimum” and “Optimum” cannot be used in going down of a lifting elevator.

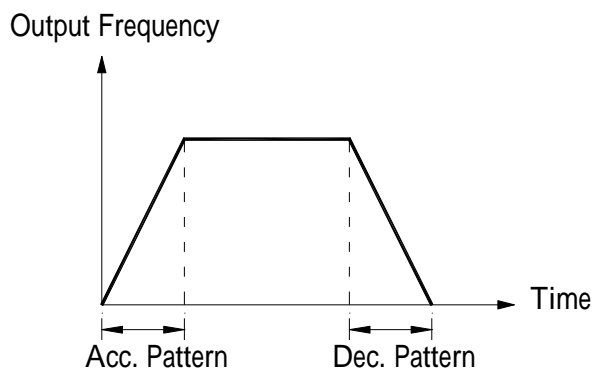

Accel/Decel Pattern:'Linear' [A-05=0 ; A-06=0]

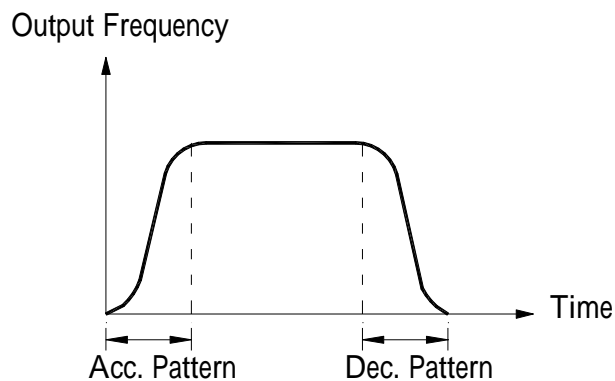

Accel/Decel Pattern:'S-Curve' [A-05=1 ; A-06=1]

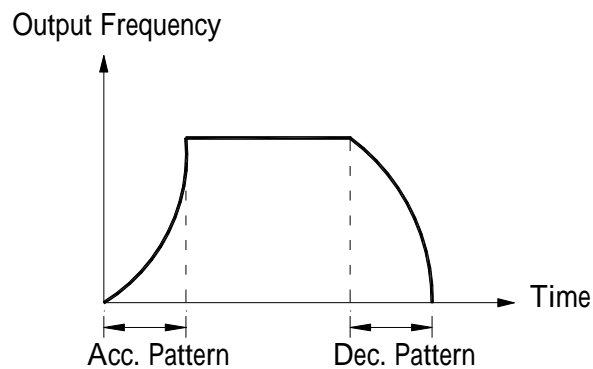

Accel/Decel Pattern:'U-Curve' [A-05=2 ; A-06=2]

**A-07 : Stop Mode**

Selects the stopping method for the inverter.

Setting Range		Description
<b>A-07</b>	0 (Factory Default) Decel	Inverter stops by the deceleration pattern. Refer to the setting of constant U-02 and A-06.
	1 DC-Brake	Inverter stops with DC injection braking. Inverter outputs DC voltage to make braking torque in motor winding when the frequency reaches the DC injection braking frequency set in A-08 during decelerating.
	2 Free-Run (Coast to stop)	Inverter cuts off its output voltage and frequency immediately when the stop signal is entered. (S1-COM OFF)

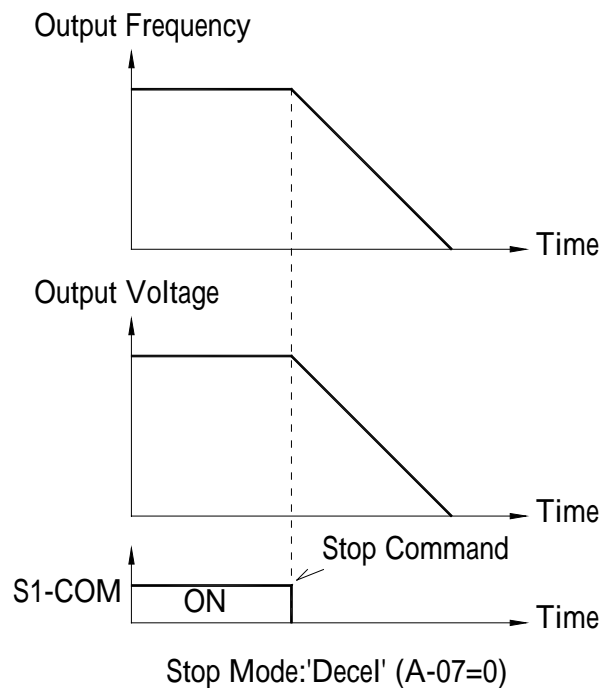

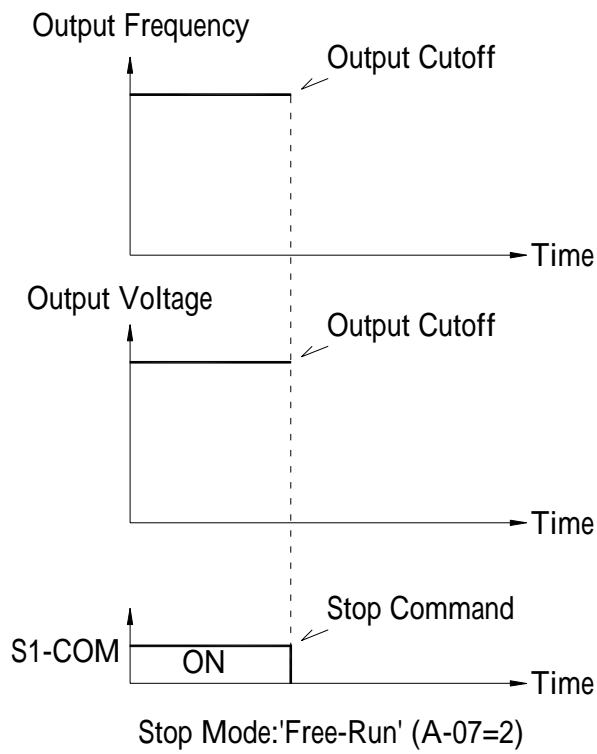
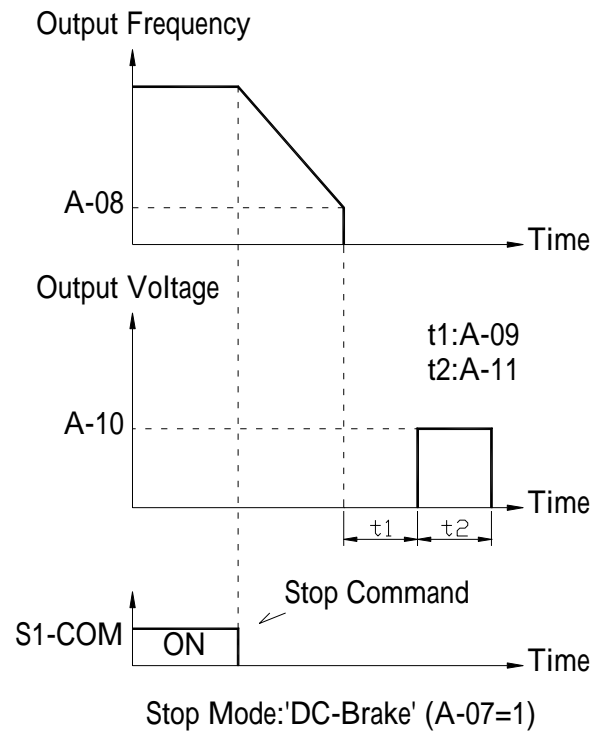

A-08 : DC Injection Braking Frequency  
 A-09 : DC Injection Braking On-delay Time  
 A-10 : DC Injection Braking Voltage  
 A-11 : DC Injection Braking Time

These functions are for adding a DC voltage into motor windings then, the motor will stop working rapidly. Selecting “DC-Brake” in A-07 (A-07=1) activates functions of constant A-08 to A-11.

A-08 [DC Injection Braking Frequency] : Inverter starts to output DC voltage to motor frequency during decelerating.

A-09 [DC Injection Braking On-delay Time] : Inverter output blocking time before DC injection braking.

A-10 [DC Injection Braking Voltage] : Adding the DC voltage to the motor windings. The setting value of A-09 is related it of b-33 [motor rated current].

A-11 [DC Injection Braking Time] : The time from DC current to the motor.

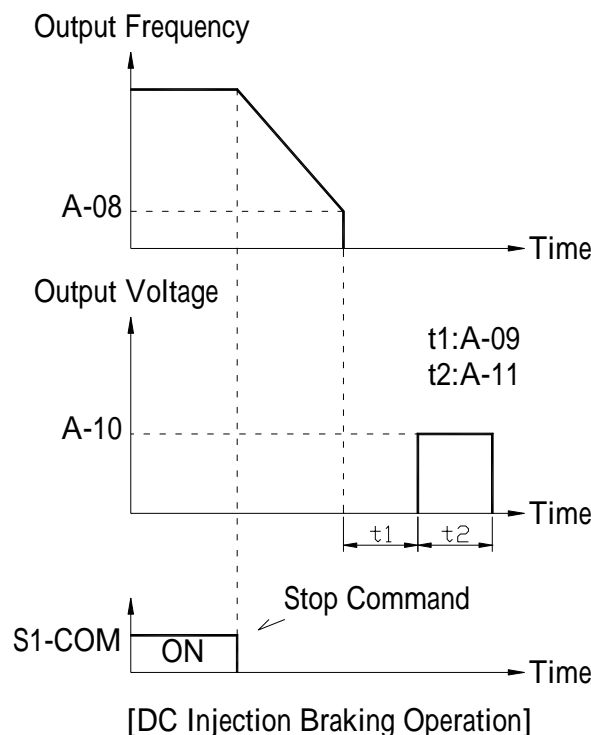

A-12 : Starting DC Injection Braking Voltage

A-13 : Starting DC Injection Braking Time

Inverter is adding A-12 [Starting DC injection braking voltage] and A-22 [Minimum output frequency] into the motor, and holding DC injection time set by in b-13.

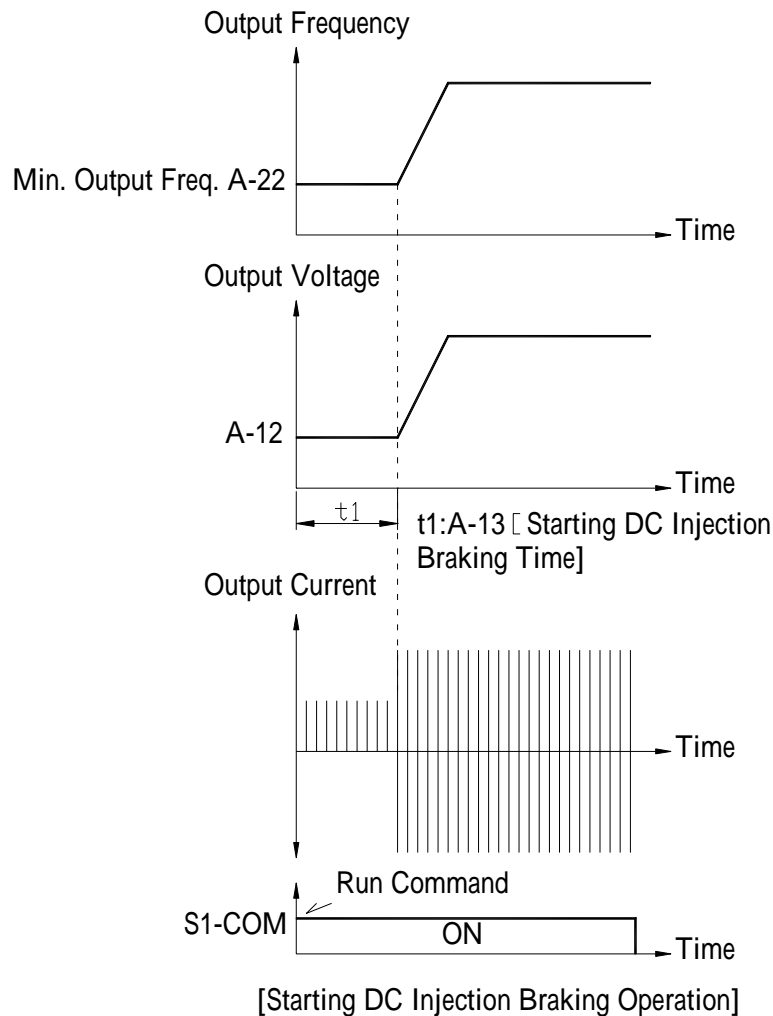

**Related Constant :**

b-33 [Motor Rated Current] {RMS}

When A-12 or A-13 is set to "0", the DC injection braking function cannot work.

When multi-function terminals (S6,S7,S8) is set as the "DC injection function during stop"(C-12=6 or C-13=6 or C-14=6), the setting value of A-12 is used as "DC injection function during stop" for output voltage level.

A-20 : Maximum Frequency  
 A-21 : Maximum Voltage Output Frequency  
 A-22 : Minimum Output Frequency

A-20 [Maximum Frequency] : The maximum output frequency of the inverter. Make sure this maximum frequency does not exceed the motor rated speed.

A-21 [Maximum Voltage Output Frequency] : The frequency of output rated voltage for inverter. When using a 50Hz motor, set it to 50Hz.

A-22 [Minimum Output Frequency] : The frequency where the inverter starts to output its voltage.

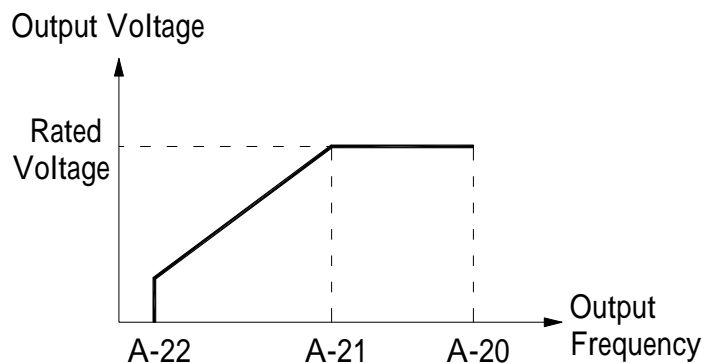

If frequency reference set point is set lower than A-22 [Minimum output frequency], the inverter will not output the voltage.

A-23 : Frequency Limit Selection  
 A-24 : Low Limit Frequency  
 A-25 : High Limit Frequency

A-23 selects the limits for the inverter operating frequency. If A-23 is set to “Yes”, the inverter operates within the upper and lower limit setting. The inverter operates at the upper or the lower limit when the frequency reference is over the frequency limit range.

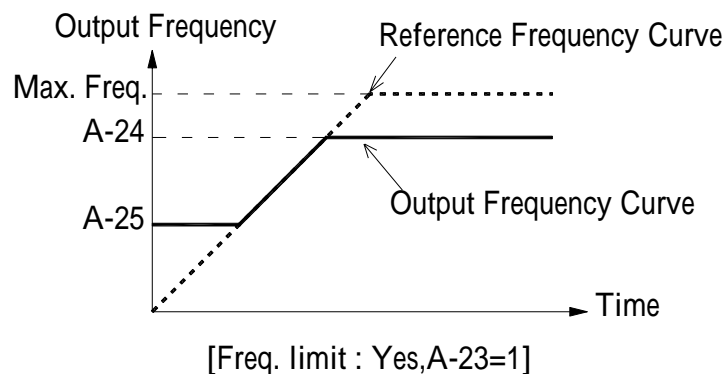

A-26 : Manual/Auto Boost Selection  
 A-27 : Torque Boost in Forward Direction  
 A-28 : Torque Boost in Reverse Direction

These functions are used to increase the starting torque at low speed by increasing the output voltage of the inverter. If the boost value is set higher than requested, it may cause the over-current trip due to over starting current. Increase the boost value when there is excessive distance between the motor and inverter.

[Manual Torque boost] : The forward and reverse torque boost is set in A-27 and A-28.

Torque boost value is the percentage of inverter rated voltage.

When A-29 [Volts/Hz Pattern] is set to "User V/F" (A-29=2), this function is disabled.

[Auto Torque Boost] : Inverter outputs higher starting torque by automatically boosting according to the load.

Auto torque boost is only available for the first group motor constants. For the second group motor constants, manual torque boost must be used.

The auto torque boost value is added to the manual torque boost value.

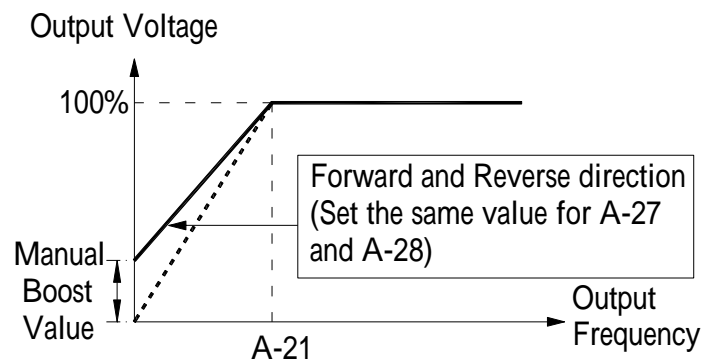

[Constant Torque Loads:Conveyor,Moving Equip.etc.]

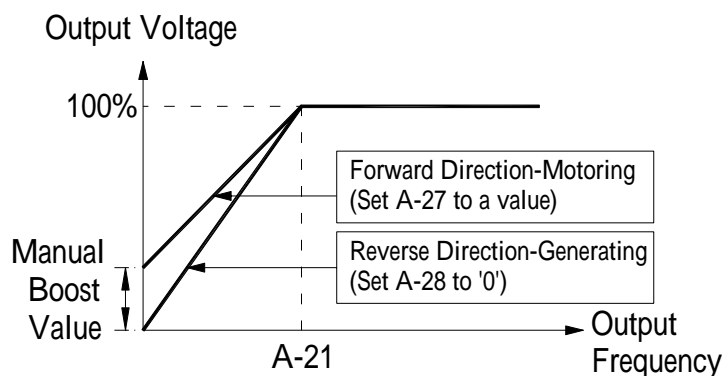

[Ascending and Descending Loads:Parking,Hoist etc.]

---

**Related Constants :**

A-29 [V/F Pattern]

b-40 [Control Mode Selection]

**A-29 : Volts/Hz Pattern**

This is the pattern of voltage/ frequency ratio. Select the proper V/F pattern according to the load. The motor torque is dependent on the V/F pattern.

[Linear] : Use [Linear Pattern] when torque control is required. This pattern maintains a linear volts/ frequency ratio from minimum output frequency to maximum voltage output frequency. Appropriate applications are convey, parking equipment etc.

[Square] : Use [Square Pattern] when the variable torque is required. This pattern maintains squared volts/ frequency ratio. Normally, this pattern is appropriate for fans, pump etc.

[User V/F] : [User V/F] pattern is used for special applications. User can adjust the V/F ratio according to different application. Set the voltage and frequency individually at 4 points between minimum output frequency and maximum voltage output frequency. The 4 points of voltage and frequency are set in A-30 to A-37 separately.

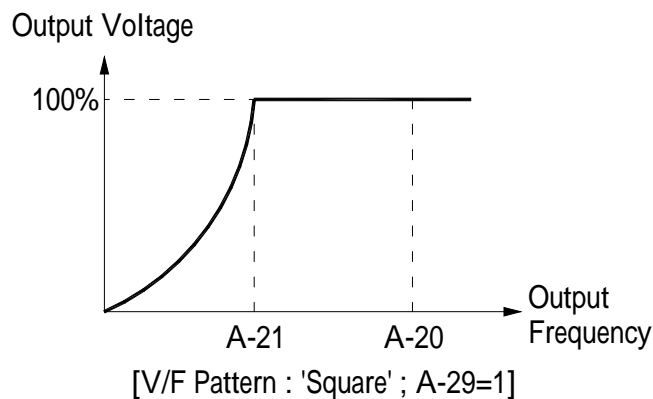
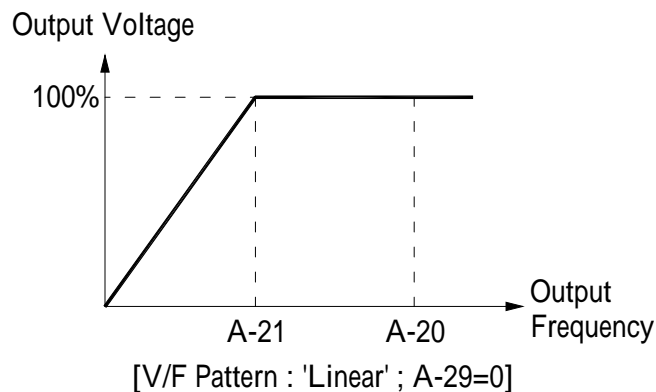

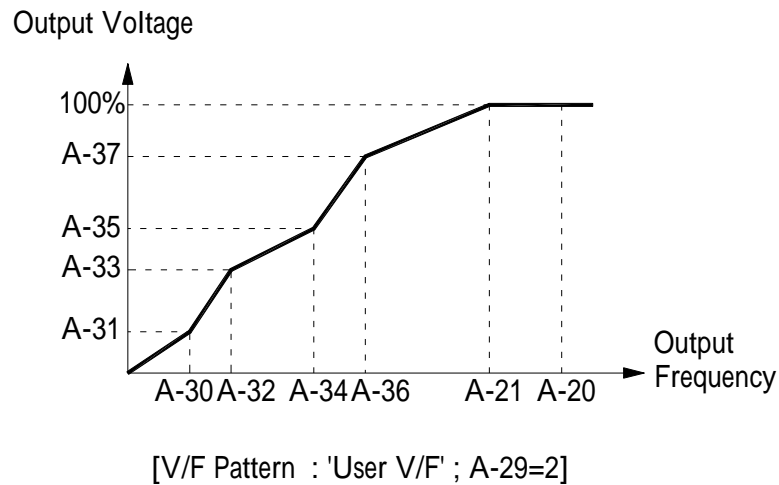

**A-30 ~ A-37 : User V/F Frequency and Voltage**

These functions are available only when “User V/F” is selected in A-29 [V/F Pattern]. User can make custom V/F pattern by setting four points between A-22 [Minimum Output Frequency] and A-21 [Maximum Voltage Output Frequency].

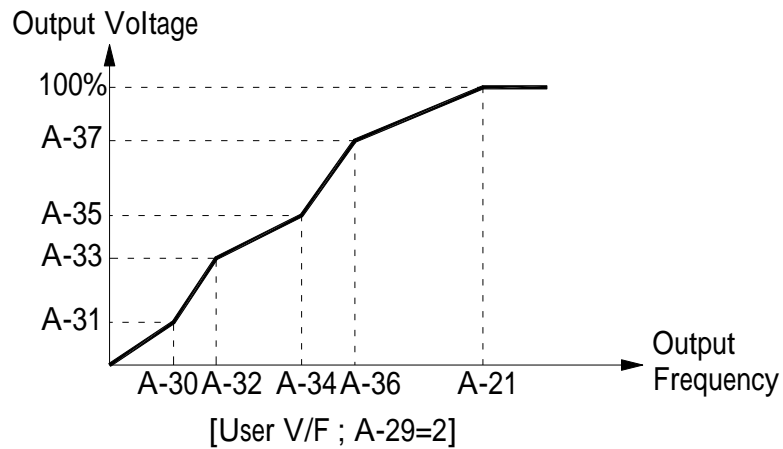

When the “User V/F” is selected, the torque boost of A-26 to A-28 is disabled.

**A-38 : Output Voltage Adjustment**

This function is used to adjust the output voltage of the inverter. When using a motor that has a lower rated voltage than the power input voltage, this function is useful. When this is set at 100%, inverter output voltage becomes the power input rated voltage.

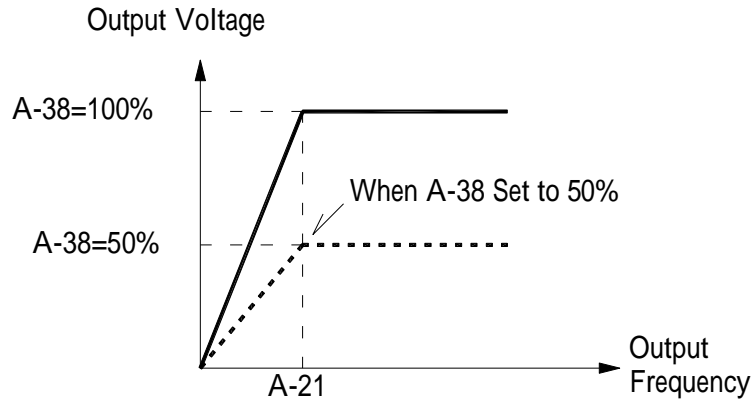

Inverter output voltage does not exceed the power input voltage when A-38 is set at 110%.

**A-39 : Energy Save Level**

This function is used to reduce the output voltage in applications that do not required high torque and current at its steady speed.

The inverter will reduce its 20% output voltage after accelerating to frequency reference (steady speed) when A-39 is set at 20%. This function may cause the over-current trip due to the reduced torque in a fluctuating load.

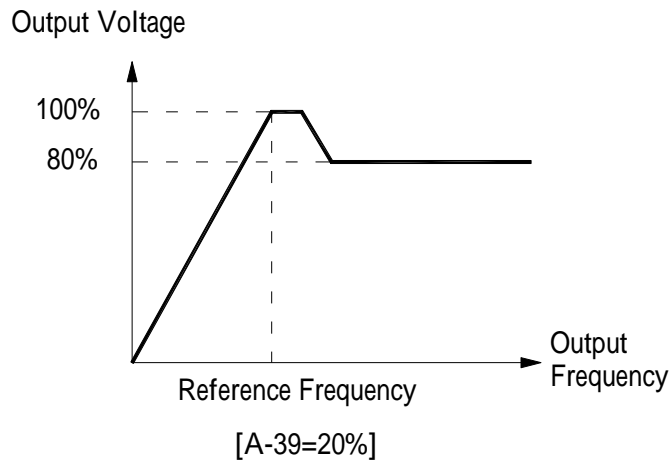

This function is not recommended for a large load or for an application that need frequent acceleration and deceleration.

---

A-50 : Electronic Thermal (Motor $i^2t$ ) Selection A-51 : Electronic Thermal Level for 1 Minute A-52 : Electronic Thermal Level for Continuous A-53 : Electronic Thermal Characteristic (Motor type) Selection
--

[A-50] : These functions are to protect the motor from overheating without using additional thermal. Inverter calculates the temperature rise of the motor by using several constants and determines whether the inverter output current may cause the motor overheating or not. Inverter cuts its output off and displays fault message when the electronic thermal is activated.

[A-51] : Inverter is dependent on motor rated current to determine whether the motor is overheated or not. When motor current is set in 150% motor rated current for over 1 minute, inverter trips immediately.

The setting value of A-51 is the percentage of b-33 [Motor Rated Current].

[A-52] : This is setting current at which the motor can run continuously. Generally, the value is set at 100% that the setting percentage is set in b-33 [Motor Rated Current]. This value must be smaller than A-51.

The setting value of A-52 is the percentage of b-33 [Motor Rated Current].

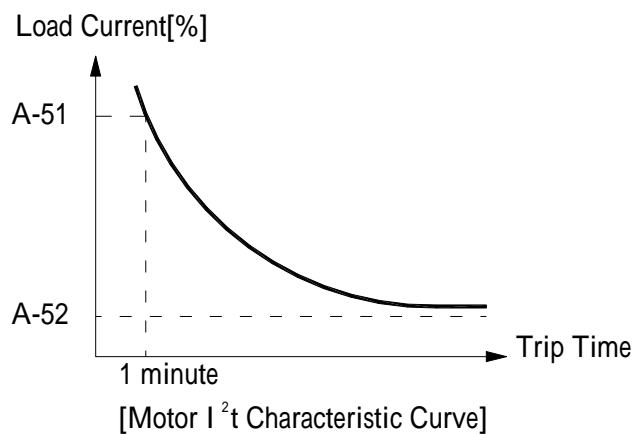

[A-53] : In order to make the electronic thermal function (Motor  $I^2t$ ) work correctly, the motor cooling method must be selected correctly according to the type of motor.

[Self-cooling] : The motor shaft is connected with a cooling fan directly. Cooling effects will reduce when the motor is running at low speeds. The motor current is decreases as the motor speed decrease.

---

[Forced-cooling] : Motor that uses a separate motor to power a cooling fan. This cooling method is not effected by variable motor speed.

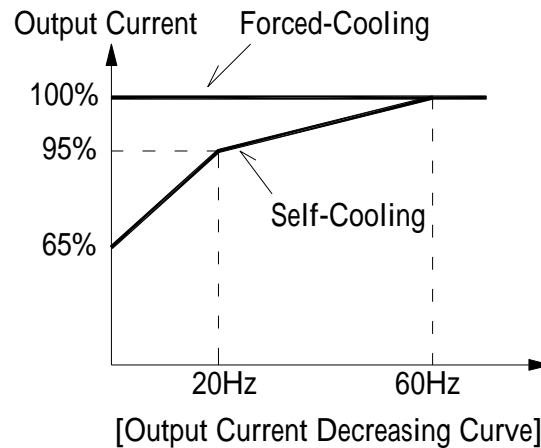

Despite the motor current changing frequently due to load fluctuation or acceleration and deceleration, the inverter calculates the  $I^2t$  and accumulates the value to protect the motor.

**Related Constant :**

b-33 [Motor Rated Current]

A-54 : Overload Warning Level

A-55 : Overload Warning Time

The inverter outputs an alarm signal A-55 [Overload Warning Time] when the output current has reached A-54 [Overload Warning Level]. The alarm signal persists for the A-55 even if the current has become the level below the A-54.

Multi-function output terminal (M1-M2) is used as alarm signal output. To output the alarm signal, set C-44 [Multi-function Output Terminal M1-M2 Selection] to "OL1" (C-44=5)

Inverter is not tripped at this function and continue its operation function. Terminal M1-M2 only outputs an alarm signal when C-44=5.

The setting value of A-54 is the percentage of b-33 [Motor Rated Current]

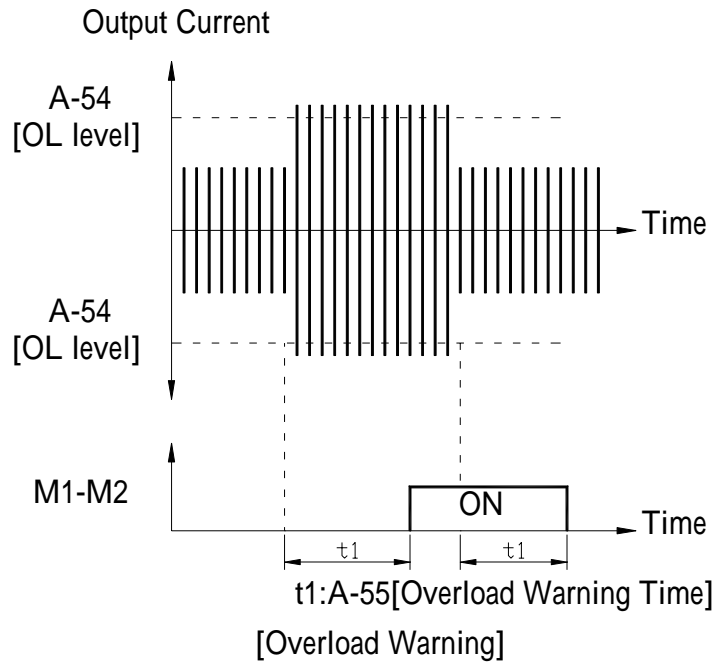

**Related Constants :**

- b-33 [Motor Rated Current]
- C-44 [Multi-function Output]

- A-56 : Overload Trip Selection
- A-57 : Overload Trip Level
- A-58 : Overload Trip Delay Time

Inverter cuts off its output and displays fault message when the output current persists over the A-57 [Overload Trip Level] for the time of A-58 [Overload Trip Time]. This function protects the inverter and motor from abnormal load conditions.

The setting value of A-57 is the percentage of b-33 [Motor Rated Current].

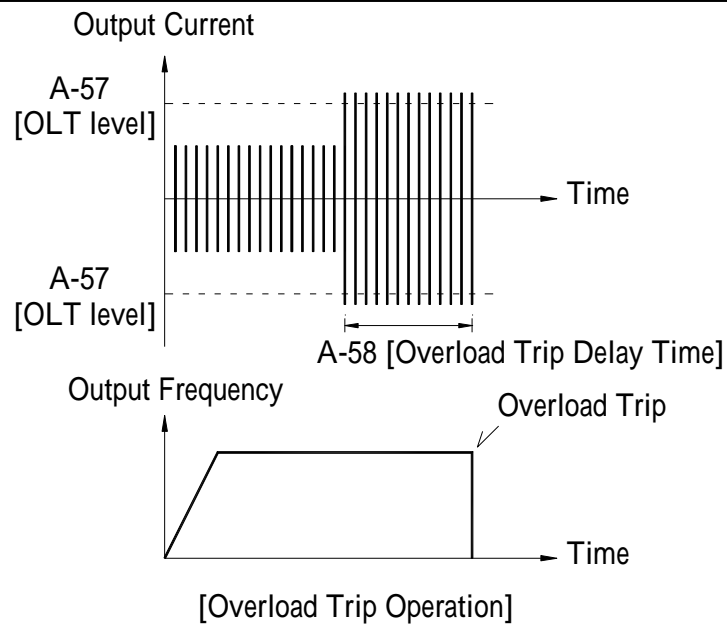

**Related Constant :** b-33 [Motor Rated Current]

A-59 : Stall Prevention Mode Selection (Bit set)  
 A-60 : Stall Prevention Level

This function is used to protect the motor by reducing the inverter output frequency until the motor current decreases below the stall prevention level. This function can be selected in any condition acceleration, steady speed, and deceleration via bit combination.

The setting value of A-60 is the percentage of b-33 [Motor Rated Current].

A-59 [Stall Prevention Mode Selection]

Setting Range			A-59	Description
3 <sup>rd</sup> bit	2 <sup>nd</sup> bit	1 <sup>st</sup> bit		
0	0	1	001	Stall Prevention during Acceleration
0	1	0	010	Stall Prevention during Steady Speed
1	0	0	100	Stall Prevention during Deceleration

When A-59 is set to “111”, stall prevention is enabled during accelerating, steady speed and decelerating.

The acceleration and deceleration time may take longer than the time set in U-01, U-02 when Stall Prevention is selected.

If stall prevention status persists, inverter may stop during acceleration.

**Related Constant :** b-33 [Motor Rated Current]

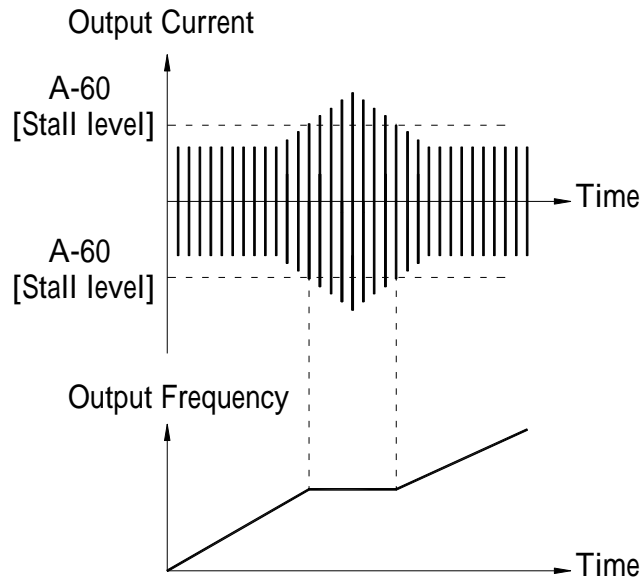

[Stall Prevention during Acceleration(A-59=001)]

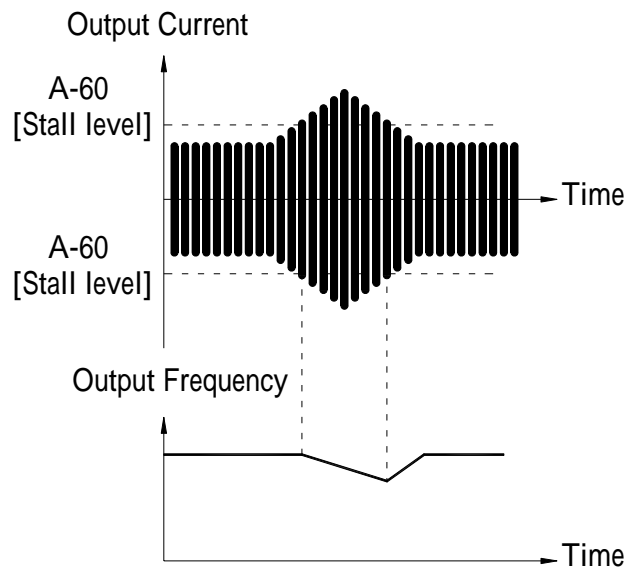

[Stall Prevention during Steady Speed(A-59=010)]

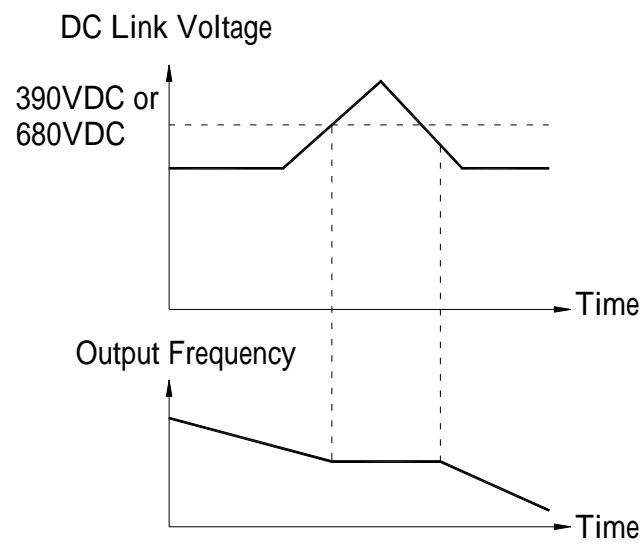

[Stall Prevention during Deceleration(A-59=100)]





A-99 : Return Code

## Function Group b (Application Group)

b-00 : Jump to Desired Constant Code #

Jumping directly to any constant(s) code can be accomplished by entering the desired function group b.

b-01 : Previous Fault History 1  
 b-02 : Previous Fault History 2  
 b-03 : Previous Fault History 3  
 b-04 : Previous Fault History 4  
 b-05 : Previous Fault History 5  
 b-06 : Erase Fault History

These constant codes display up to five previous fault message of the inverter. Use the  key,   key before pressing  key to check the fault content(s), output current. Or whether the inverter is during accelerating, decelerating, steady run before the fault occurs. The fault content will be stored in b-01 to b-05 when the  is pressed. For more detail information, please refer to Chapter 5.

Display of digital operator	Fault Status (Trip)	
OC	Over current	
OV	Over voltage	
UV	Low voltage	
OH	Overheat on heat sink	
ETH	Electronic thermal trip	
OL1	Motor overload	
OL2	Inverter overload	
PF	Inverter input phase loss	
LF	Inverter output phase loss	
EF1	Emergency stop (Terminal S3 closed.)	
CPF5 Inverter Hardware Fault	CPF3	CPU EEPROM error
	FAn	Inverter cooling fan fault
	CPF4	CPU error
	GF	Ground Fault
	ntC	NTC damage

When CPF5 (Inverter Hardware Fault) occurs, “RESET” function is disabled. Repair the fault before turning on the power.

**Related Constant :** U-12 [Fault Display] : Displays current fault status.

b-06 erases all fault histories of b-01 to b-05 from the memory.

b-07 : Dwell Frequency

b-08 : Dwell Time

This function is used to output torque in an intended direction. It is useful in hoisting mechanical device to obtain enough torque before releasing mechanical brake. If b-08 is set at “0”, this function is not available. During Dwell operation (Dwell Time), the inverter outputs an AC voltage, not a DC voltage.

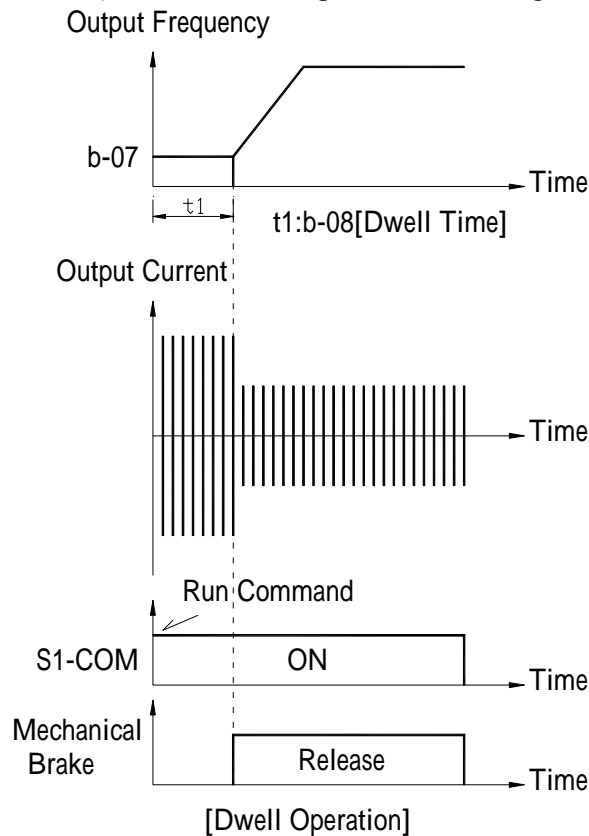

DC injection braking does not output torque to an intended direction. It is just to hold the motor.

- b-10 : Frequency Jump Selection
- b-11 : Jump Frequency 1 (Low)
- b-12 : Jump Frequency 1 (High)
- b-13 : Jump Frequency 2 (Low)
- b-14 : Jump Frequency 2 (High)
- b-15 : Jump Frequency 3 (Low)
- b-16 : Jump Frequency 3 (High)

To prevent undesirable resonance and vibration on the mechanical structure, this function avoids the potential resonance frequency from running process. Three different jump frequency ranges can be set. No jump frequency happening during accelerating and decelerating. It only occurs during continuous operation.

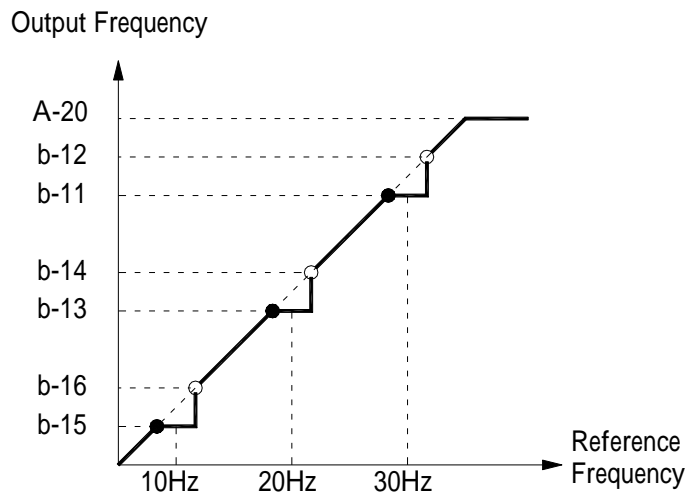

When frequency is set in jump frequency, the output frequency goes to the frequency marked by “ ” symbol, and then jump to the frequency marked by “ ” by symbol.  
 If one jump frequency is required, set all the jump frequency range to the same range.

**b-19 : Input/Output Phase Loss Protection (Bit Set)**

This function is used to cut the inverter output off in case of phase loss in either input power or inverter output.

**b-19 [Phase Loss Protection Select]**

Setting Range		b-19	Description
2 <sup>nd</sup> bit	1 <sup>st</sup> bit		
0	0	00	Phase loss protection does not work
0	1	01	Starting the output phase loss function.
1	0	10	Starting the input phase loss function.
1	1	11	Starting the input/ output phase loss.

## b-20 : Power ON Start Selection

If b-20 is set to “NO” (b-20=0), restart the inverter by cycling the terminal S1 or S2 to terminal COM after power has been restored. If b-20 is set to “YES” (b-20=1), restart the inverter immediately after the power is restored. If the motor is still rotating due to inertia at the time power is restoring, the inverter may trip if start the inverter immediately. To avoid the trip, use “Speed Search” function by setting b-22 to “1xxx”. Please refer detail information to constant description b-22.

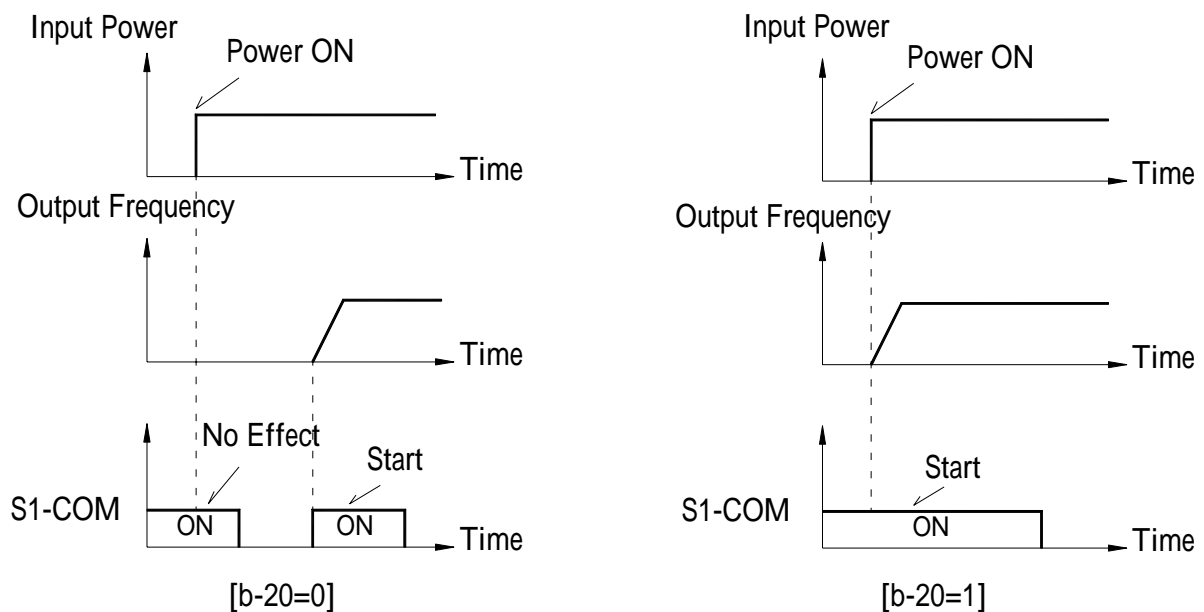

## b-21 : Restart After Fault Reset

If b-21 is set to “YES” (b-21=1), inverter will restart immediately after the reset terminal signal (S4-COM ON) is shown.

If b-21 is set to “NO” (b-21=0), inverter will restart after reset terminal (S4-COM ON) and have terminal S1 or S2 cycling the terminal COM.

The inverter may trip if the motor is rotating by inertia at the time the inverter restarts. To avoid the trip, use “Speed Search” function by setting b-22 to “xx1x”

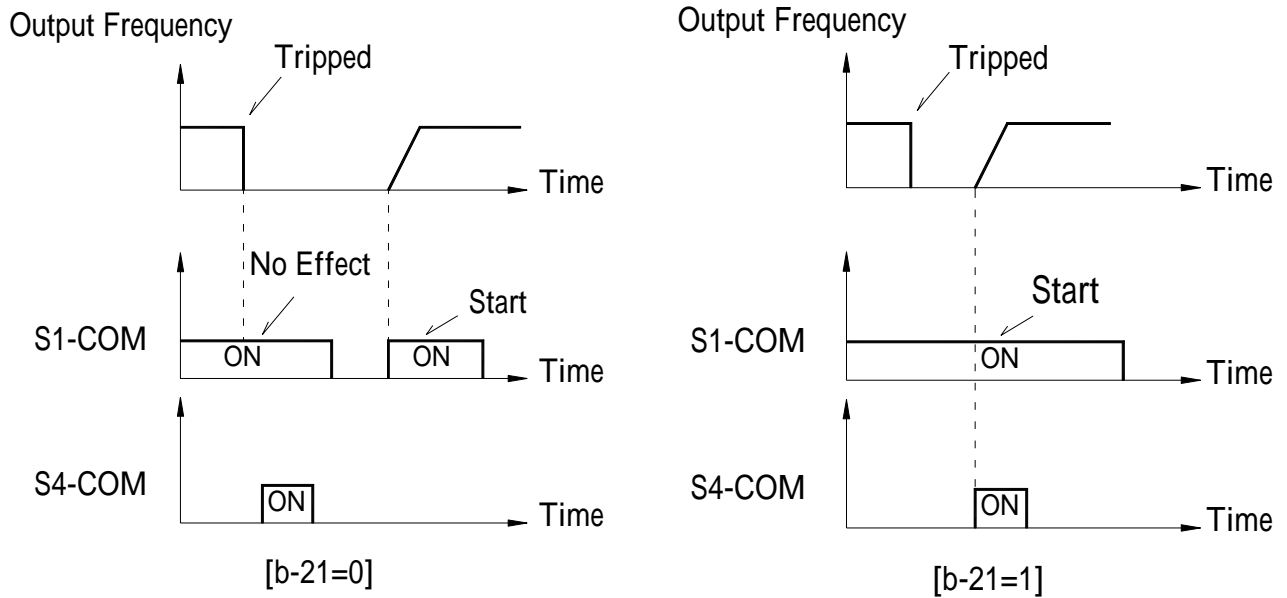

- b-22 : Speed Search Selection (Bit Set)
- b-23 : Current Limit Level During Speed Search
- b-24 : P Gain During Speed Search
- b-25 : I Gain During Speed Search

This function is used to permit automatic restarting after power ON, fault reset and instant power failure without waiting for the motor to stop.

The speed search gain can be set after considering the inertia moment ( $GD^2$ ) and magnitude of torque of the load. To make sure b-22 operate correctly, b-37 [Load Inertia] must be set at the correct value.

#### b-22 [Speed Search Select]

Setting Range				Description
4 <sup>th</sup> bit	3 <sup>rd</sup> bit	2 <sup>nd</sup> bit	1 <sup>st</sup> bit	
0	0	0	0	Speed search function does not work.
0	0	0	1	Speed search during accelerating.
0	0	1	0	Speed search during a fault reset restarting (b-21) and auto restarting (b-26).
0	1	0	0	Speed search during instant power failure restarting.
1	0	0	0	Speed search during power ON starting (b-20)

When b-22 is set to “111”, speed search performs under all the conditions.

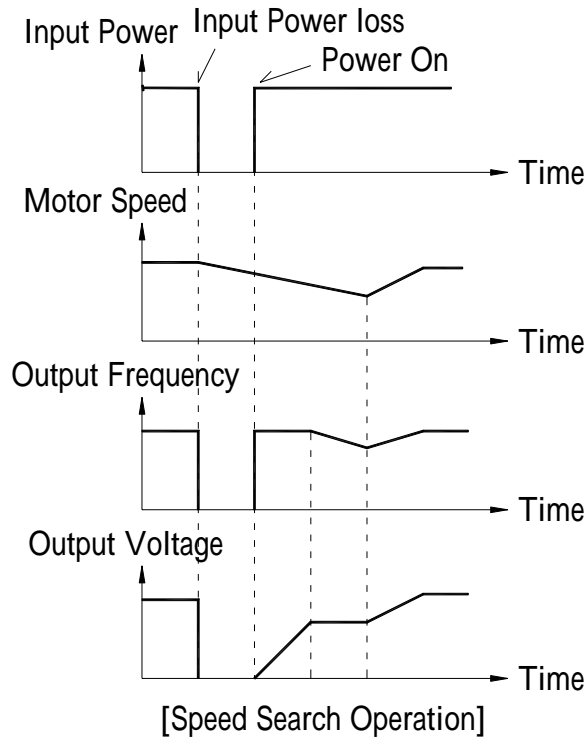

b-22 [Speed Search Selection] : Select the speed search function.

b-23 [Current Limit Level During Speed Search] : Inverter limit current goes up during the speed search. The setting value is the percentage of b-33 [Motor Current Rated].

b-24 [P Gain] : The proportional gain used for speed search. Set this value according to the load inertia set in b-37.

b-25 [I Gain] : The integral gain used for speed search. Set this value according to load inertia set in b-37.

**Related Constant :**

- b-20 [Power ON Start Selection]
- b-21 [Restart after Fault Reset]
- b-26 ~ b-27 [Number of Auto Restart Attempt]
- b-30 ~ b-37 [Motor Constants]

b-26 : Number of Auto Restart Attempt  
b-27 : Delay Time Before Auto Restart

This function is used to allow the inverter to reset itself for b-26 selected number of times after a fault is reset. Inverter automatic restart after the fault occurs. In order to use the speed search function during auto restarting, set b-22 to “xx1x”. Please refer to b-22 to b-25.

When an under voltage (Uv) fault, terminal S3 and COM ON and IGBT of inverter are shorted, the inverter will not restart automatically.

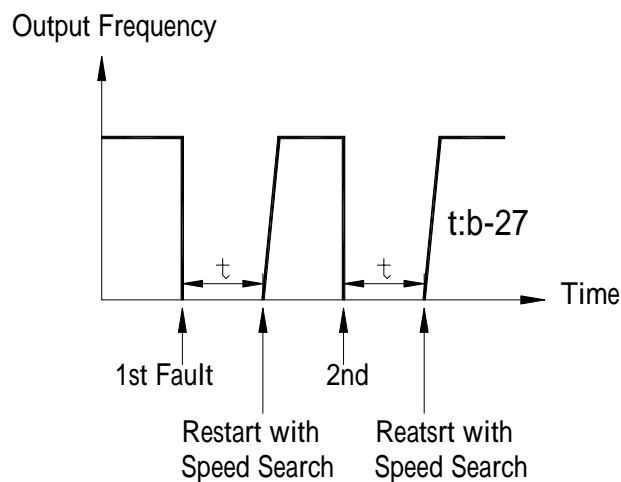

Inverter decreased its number of auto restart for once when the fault occurs. If there is no fault occurring within 30 seconds after auto restart, inverter will increase its retry number by once.

b-30 : Rated Motor Selection  
b-31 : Number of Motor Pole  
b-32 : Rated Motor Slip  
b-33 : Rated Motor Current  
b-34 : No Load Motor Current  
b-36 : Motor Efficiency  
b-37 : Load Inertia

If these values are not set, inverter will use its default values.

[b-30] : b-30 is used to set the capacity of motor. If this value is changed, other motor related constants are changed automatically. Other related constants are b-32 [Motor Rated Slip], b-33 [Motor Rated Current], b-34 [No Load Motor Current]. To have better control performance, please refer to adjustable setting value of other related constant codes if user knows the motor constants.

---

[b-31] : This constant is related to U-09, motor speed display. If user sets the value to 2, then U-09 displays 3600rpm at 60Hz output frequency, not 800rpm at 60Hz output frequency. (Refer to motor nameplate)

[b-32] : This is used in “Slip Compensation” control. If user set this value incorrectly, motor may stall during slip compensation control. (Refer to motor nameplate)

[b-33] : This constant value must be set correctly as it is very important constant. This value is referred by many other constants. (Refer to motor nameplate)

[b-34] : This constant is only displayed when “Slip Compensation” is selected in b-40 [Control Method].

This function is used to maintain constant motor speed. To keep the motor speed constant, the output frequency varies within the limit of slip frequency set in b-32 according to the load current. For example, inverter increases output frequency higher than the reference frequency to increase the motor speed when the motor speed decreases below the reference speed (frequency) due to a heavy load.

$$\text{Delta Frequency} = \frac{\text{Output current} - \text{No load current}}{\text{Rated current} - \text{No load current}} \times \text{Rated Slip}$$

Inverter output frequency = Reference frequency + Delta frequency.

[b-36] : This value is used to calculating the output wattage when b-72 is set to “Watt”.

[b-37] : This constant is used for sensorless control, minimum Accel/ Decel, optimum Accel/ Decel and speed search. For better control performance, this value must be set as exact as possible.

Set to

0 : Loads inertia less than 10 times of motor inertia.

1 : Loads inertia is 10 times of motor inertia.

2 : Loads inertia bigger than 10 times of motor inertia.

#### **b-39 : Carrier Frequency**

[b-39] : This constant affects the audible sound of the motor, noise emission from the inverter, inverter temperature, and leakage current. If the ambient temperature where the inverter is installed is high or other equipment may be affected by potential inverter noise, decrease the setting value of b-39. At the same time, adjusting carrier frequency can also avoid induced resonance in the machine and motor.

If this value must be higher than 3 kHz, decreases inverter load current by 5% per increases 1 kHz.

---

**b-40 : Control Method Selection**

Select control method of the inverter.

Setting Range		Description
<b>b-40</b>	0 V/F	V/F Control
	1 Slip compensation	Slip compensation operation
	2 PID	PID feedback control

[V/F] : It maintains the same voltage/ frequency ratio constant. It is recommended to use the torque boost function when a greater starting torque is requested.

**Related Constant : b-26 ~ b-28 [Torque Boost]**

[Slip Compensation] : This function is used to maintain constant motor speed. To keep the motor speed constant, the output frequency varies within the limit of slip frequency set in b-32 according to the load current. For example, when the motor speed decreases below the reference speed (frequency) due to a heavy load, the inverter will increase its output frequency to be higher than the reference frequency to increase the motor speed.

$$\text{Delta Frequency} = \frac{\text{Output current} - \text{No load current}}{\text{Rated current} - \text{No load current}} \times \text{Rated Slip}$$

For better control performance, the motor constants must be set correctly.

**Related Constant : b-30 ~ b-37 [Motor Parameters]**

[PID] : For HVAC or pump applications, the PID control can be used to adjust the actual output by comparing a feedback value with setting value of inverter. The “Set-point” can be in the form of speed, temperature, pressure, flow level, etc. All of the set-point and feedback signal are provide to the inverter analog input terminals Vs or Is. Inverter outputs a adjust frequency value to motor after PID controller is calculated. Please refer to b-50 to b-54 for more detail.

**Related Constant : b-50 ~ b-54 [PID Feedback]**

- b-50 : PID Feedback Signal Selection
- b-51 : P Gain for PID Control
- b-52 : I Gain for PID Control
- b-53 : D Gain for PID Control
- b-54 : Limit Frequency for PID Control

[PID] : For HVAC or pump applications, the PID control can be used to adjust the actual output by comparing a feedback value with setting value of inverter. The “Set-point” can be in the form of speed, temperature, pressure, flow level, etc. All of the set-point and feedback signal are provided to the inverter analog input terminals Vs or Is. Inverter outputs a adjust frequency value to motor after PID controller is calculated. Please refer to b-50 to b-54 for more detail.

PID control can be manual operation temporarily by setting multi-function input terminals (S6~S8) to “Open Loop”. The inverter will change to manual operation from PID control when this terminal is ON, and change back to PID control when this terminal is OFF.

[b-50] : Select the feedback signal for PID control. It can be set one of “Vs”, “Is” according to the signal (voltage or current).

[b-51] : Set the proportional gain for PID control.

[b-52] : Set the integral gain for PID control.

[b-53] : Set differential gain for PID control.

[b-54] : This is the frequency at which the output frequency is limited during PID control.

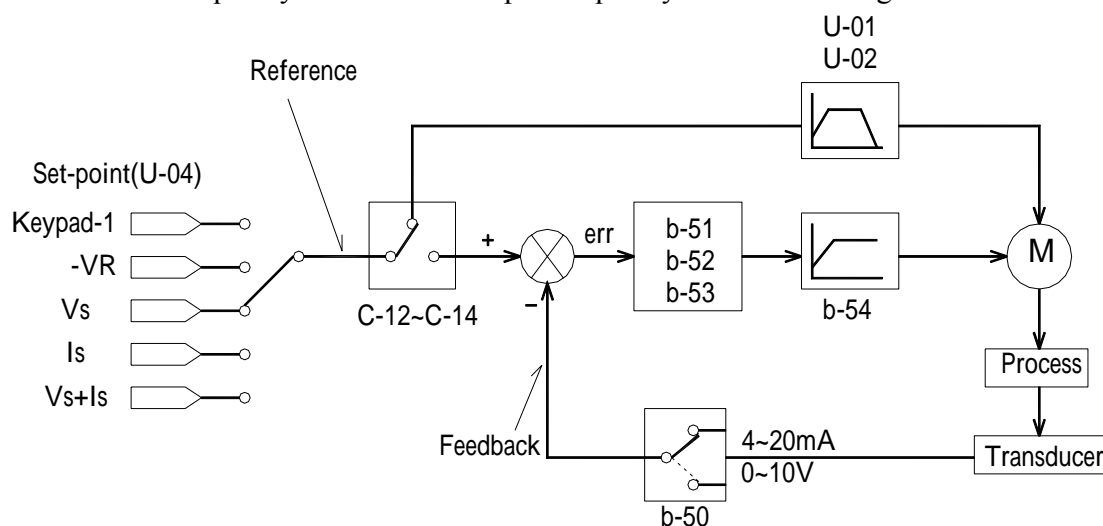

[PID Control Block Diagram]

[P Control] : This is to compensate the error of a system proportionally. This function is used to make the controller response fast for an error. When P control is used alone, the system is easily affected by an external disturbance during steady state.

[I Control] : This is to compensate the error of system by integrally. This is used to compensate the steady state error by accumulating them. Using this control alone makes the system unstable.

[PI Control] : This control method works stable in many systems. If “D Control” is added to this system, then it becomes the 3<sup>rd</sup> order system. In some systems this may lead to system instability.

[D Control] : Since the D control uses the variation ratio of error, it has the merit of controlling the error before the error is too large. The D control requires a large control quantity at start, but has the tendency of increasing the stability of the system. This control does not affect the steady state error directly, but increases the system gain because it has an attenuation effect on the system. As a result, the differential control component has an effect on decreasing the steady state error. Since the D control operates on the error signal, it cannot be used alone. Always use it with the P control or PI control.

**Related Constants :**

- U-04 [Frequency Mode]
- b-40 [Control Method]
- C-01 ~ C-10 [Analog Signal Scaling]

**b-70 : Reference Frequency for Accel/Decel**

This is the reference frequency for acceleration and deceleration. If a decided Accel/Decel time from a frequency to a target frequency is required, set this value to “Delta freq”.

Setting Range		Description
<b>b-70</b>	0 Max freq	The Accel/Decel time is the time that takes to reach the maximum frequency from 0 Hz.
	1 Delta freq	The Accel/Decel time is the time that takes to reach a target frequency from a frequency.

**Related Constants :**

- U-01, U-02 [Accel/Decel Time]
- b-71 [Accel/Decel Time Scale]
- C-25 ~ C-38 [1<sup>st</sup> ~ 7<sup>th</sup> Accel/Decel Time]

**b-71 : Accel/Decel Time Scale**

This is used to change the time scale.

Setting Range		Description
b-71	0 0.01 sec	The Accel/Decel time is changed by 0.01 second. The maximum setting range is 600 seconds.
	1 0.1 sec	The Accel/Decel time is changed by 0.1 second. The maximum setting range is 6000 seconds.
	2 1 sec	The Accel/Decel time is changed by 1 second. The maximum setting range is 60000 seconds.

**Related Constants :**

U-01, U-02 [Accel/Decel Time]  
b-70 [Reference Freq. for Accel/Decel]  
C-25 ~ C-38 [1<sup>st</sup> ~ 7<sup>th</sup> Accel/Decel Time]

**b-72 : Power On Display**

This code selects the parameter to be displayed first on keypad (U-00) when the power is turned on.

Setting Range	Description
0	U-00 [Reference Frequency during stop ; Output Frequency during running]
1	U-01 [Acceleration Time]
2	U-02 [Deceleration Time]
3	U-03 [Drive Mode]
4	U-04 [Frequency Mode]
5	U-05 [Step Frequency 1]
6	U-06 [Step Frequency 2]
7	U-07 [Step Frequency 3]
8	U-08 [Output Current]
9	U-09 [Motor Speed]
10	U-10 [DC link Voltage]
11	U-11 [b-73 Selection Display]
12	U-12 [Fault Display]
13	U-13 [Motor Direction Set]

**b-73 : U-11 Selection Display**

This constant code set the meaning of display code in U-11.

Setting range		Description
<b>b-73</b>	0 Voltage	Displays the output voltage of inverter.
	1 Watt	Displays the output power of inverter.
	2 Torque	Displays the output torque of inverter.

#### b-74 : Gain for Motor Speed Display

This code is used to change the motor speed display to rotating speed (r/min) or mechanical speed (m/min). The display is calculated by following equation.

Rotating Speed =  $120 \times F / P$ , where F = Output frequency, P = motor pole number

Mechanical Speed = Rotating speed x Motor RPM Display Gain

#### Related Constants :

U-00 [Output Frequency]

U-09 [Motor Speed]

b-31 [Motor Pole]

#### b-75 : DB (Dynamic Braking) Resistor Mode Selection

Setting Range		Description
<b>b-75</b>	0 (None)	No external DB resistor, no DB signal.
	1 (None)	
	2 (Ext. DB-R) (Factory Default)	Select external DB resistor.

#### b-76 : Duty of DB (Dynamic Braking) Resistor

$$\%ED = \frac{\text{Decel. Time}}{(\text{Accel. Time} + \text{Reference Freq. Operation Time} + \text{Decel. Time} + \text{Stop Time})} \times 100\%$$

Set the duty of DB resistor when select external DB resistor.

---

**b-79 : Software Version**

Displays the software version of EI-500.

- b-81 : 2<sup>nd</sup> Acceleration Time
- b-82 : 2<sup>nd</sup> Deceleration Time
- b-83 : 2<sup>nd</sup> Base Frequency
- b-84 : 2<sup>nd</sup> V/F Pattern
- b-85 : 2<sup>nd</sup> Forward Torque Boost
- b-86 : 2<sup>nd</sup> Reverse Torque Boost
- b-87 : 2<sup>nd</sup> Stall Prevention Level
- b-88 : 2<sup>nd</sup> Electronic Thermal Level for 1 Minute
- b-89 : 2<sup>nd</sup> Electronic Thermal Level for Continuous
- b-90 : 2<sup>nd</sup> Motor Related Current

These functions are displayed only when any of the multifunction inputs (S6, S7, S8) is set at “2<sup>nd</sup> function” in C-12 to C-14, then these functions are effective. When using two motors with an inverter by exchanging them, different values can be set for the 2<sup>nd</sup> motor by using the multifunction input terminal. Following table is the 2<sup>nd</sup> functions corresponding to the 1<sup>st</sup> functions.

2 <sup>nd</sup> Functions	1 <sup>st</sup> Functions	Description
b-81 [2nd Acc time]	U-01 [Acc. time]	Acceleration time
b-82 [2nd Dec time]	U-02 [Dec. time]	Deceleration time
b-83 [2nd Base Freq]	A-21 [Base freq]	Output frequency at maximum voltage
b-84 [2nd V/F]	A-29 [V/F Pattern]	V/F pattern
b-85 [2nd F-boost]	A-27 [Fwd Boost]	Manual forward torque boost
b-86 [2nd R-boost]	A-28 [Rev Boost]	Manual reverse torque boost
B-87 [2nd Stall]	A-60 [Stall Level]	Stall prevention level
B-88 [2nd ETH 1min]	A-51 [ETH 1min]	ETH level for 1 minute
B-88 [2nd ETH cont]	A-52 [ETH cont]	ETH level for continuous
B-90 [2nd R-Curr]	B-33 [Rated-Curr]	Motor rated current

The 1<sup>st</sup> functions are applied if the multi-function terminal is not defined to “2<sup>nd</sup> Function” or if it is not ON. The 2<sup>nd</sup> function constants are applied when the multi-function input terminal set to “2<sup>nd</sup> Function” is ON. Parameters not listed on the table above are applied to the 2<sup>nd</sup> motor as to the 1<sup>st</sup> motor.

Exchange the motor connection from the 1<sup>st</sup> motor to the 2<sup>nd</sup> motor or the opposite when the motor is stopped. Over voltage or over current fault can occur when the motor connection is exchanged during operation.

The “User V/F” function of A-29 [Volts/Hz Pattern] is used for both the 1<sup>st</sup> motor and the 2<sup>nd</sup> motor.

b-91 : Constant Read

b-92 : Constant Write

This is useful for programming multiple inverters to have same parameter settings. The keypad can read (upload) the parameter settings from the inverter memory and can write (download) them to other inverters.

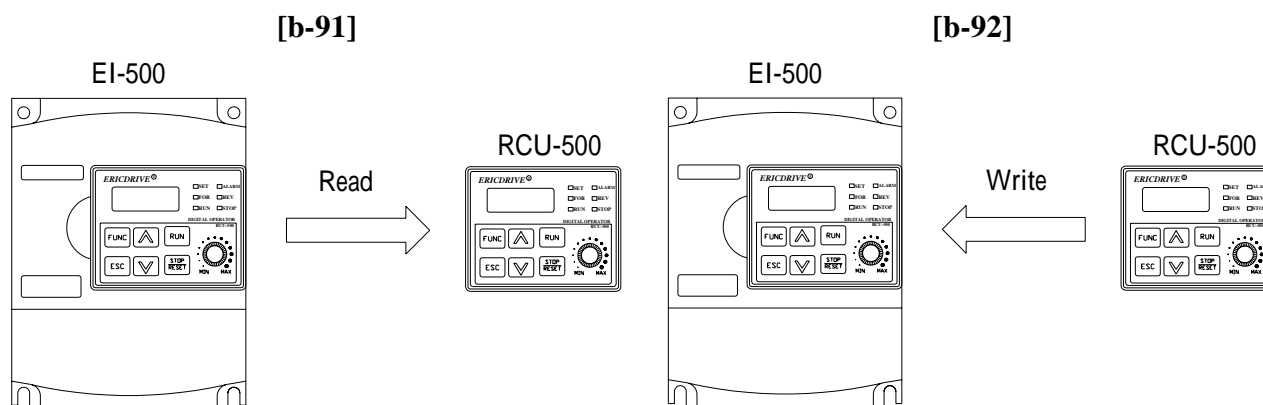

b-93 : Parameter Initialize

This is used to initialize parameters back to the factory default values. Each function group can be initialized separately.

b-93	Description
0	Displayed after initializing parameters.
1	All constant groups are initialized to factory default value.
2	Only Function group U is initialized.
3	Only Function group A is initialized.
4	Only Function group b is initialized.
5	Only Function group C is initialized.

---

**b-94: Parameter Write Protection**

This function is used to lock the constants from being changed. The lock and unlock code is “6”. Digital operator displays “U - - 0” when unlocked and “L - - 0” when locked.

**b-99: Return Code**

---

## Function Group C (Multi-function terminal constant group)

C-00 : Jump to Desired Code #

Jumping directly to any constant code can be accomplished by entering the desired code number.

C-01 : Filtering Time Constant for Vs Signal Input  
C-02 : Vs Input Minimum Voltage  
C-03 : Frequency corresponding to Vs Input Minimum Voltage  
C-04 : Vs Input Maximum Voltage  
C-05 : Frequency corresponding to Vs Input Maximum Voltage

This is used to adjust the analog voltage input signal when the frequency is referred by the digital operator potentiometer or external terminal “Vs”. This function is applied when U-04 is set to “U-04=1” or “U-04=2” or “U-04=4”. Reference frequency versus Analog voltage input curve can be made by four constants of C-02 ~ C-04.

- [C-01] : This is the filtering time constant for digital operator potentiometer or Vs signal input. Increase this value if the analog signal is affected by noise causing unstable operation of the inverter. Increasing this value makes response time slower.
- [C-02] : This is the minimum voltage of the digital operator potentiometer or terminal Vs input at which inverter outputs minimum frequency.
- [C-03] : This is the inverter output minimum frequency when there is the minimum voltage (C-02) on the digital operator potentiometer or terminal Vs.
- [C-04] : This is the maximum voltage of the digital operator potentiometer output or terminal Vs input at which inverter outputs maximum frequency.
- [C-05] : This is the inverter output maximum frequency when there is the maximum voltage (C-04) on Vs terminal or the max. voltage is output by potentiometer of digital operator.

### Reference Frequency

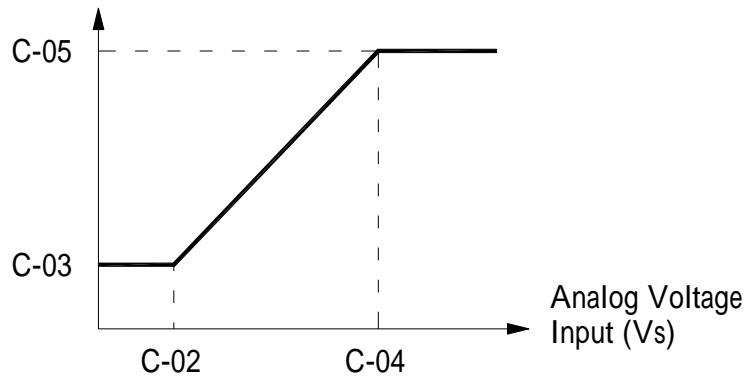

[Reference Frequency vs. Analog Voltage Input, Vs(0~+10V)]

#### Related Constants :

- U-04 [Frequency Mode]
- A-20 [Maximum Output Frequency]

- C-06 : Filtering Time Constant for Is Signal Input
- C-07 : Is Input Minimum Current
- C-08 : Frequency corresponding to Is Input Minimum Current
- C-09 : Is Input Maximum Current
- C-10 : Frequency corresponding to Is Input Maximum Current

These functions are used to adjust the analog current input signal when the external terminal Is references the frequency. This function is applied when U-04 is set to "Is" (U-04=3) or "Vs+Is" (U-04=4). Reference frequency versus Analog current input curve can be made by four parameters of C-07 ~ C-10.

[C-06] : This is the filtering time constant for "Is" signal input. If the "Is" signal is affected by noise causing unstable operation of the inverter, increase this value. Increasing this value makes response time slower.

[C-07] : This is the minimum current of the "Is" input at which inverter outputs minimum frequency.

[C-08] : This is the inverter output minimum frequency when there is minimum current (C-07) on the "Is" terminal.

[C-09] : This is the maximum current of the terminal "Is" input at which inverter outputs maximum frequency.

[C-10] : This is the inverter output maximum frequency when there is the maximum current (C-09) on the "Is" terminal.

### Reference Frequency

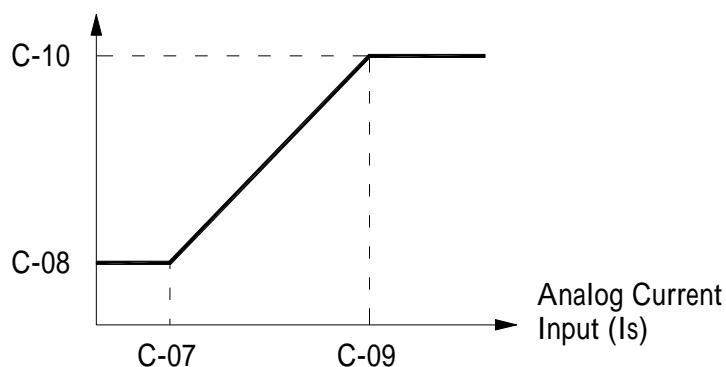

[Reference Frequency vs. Analog Current Input, Is(4~20mA)]

#### Related Constant :

- U-04 [Frequency Mode]
- A-20 [Maximum Frequency]

#### C-11 : Criteria for Analog Input Signal Loss

This is to set the criteria for analog input signal loss when U-04 [Frequency Mode] is set to “Vs”(U-04=2), “Is”(U-04=3) or “Vs+Is”(U-04=4). Following table shows the setting value.

Setting Range		Description
<b>C-11</b>	0 (Factory Default)	Does not check the analog input signal.
	1 half of x1	The inverter determines that the frequency reference is lost when the analog input signal is less than half of the minimum value (C-02 or C-07).
	2 below x1	The inverter determines that the frequency reference is lost when the analog input signal is less than the minimum value (C-02 or C-07).



When the analog input signal is lost, inverter displays the following.

**LOSt**

Related Constants : C-48 [Operating selection at Loss of Freq. Reference] selects the operation after determining the loss of frequency reference. The following table shows the selection in C-48.

Setting Range		Description
<b>C-48</b>	0 (Factory Default)	Continuous operating after loss of frequency reference.
	1 Free Run	Inverter cuts off its output after determining loss of frequency reference.
	2 Stop	Inverter stops by its Decel pattern and Decel time after determining loss of frequency reference.

C-49 [Waiting Time after Loss of Freq. Reference] sets the waiting time when determining the loss of reference signal. Inverter waits to determine the loss of a reference signal until times out.

C-48 and C-49 also apply when U-04 is set to “ ,  key of digital operator” (U-04=0) or “potentiometer of digital operator” (U-04=1) for determining the loss of command frequency.

C-12 : Multi-function Input Terminal “S6” Selection

C-13 : Multi-function Input Terminal “S7” Selection

C-14 : Multi-function Input Terminal “S8” Selection

Multi-function input terminals (S6, S7, S8) can be defined for many different applications. The following table shows the various definitions for them.

Setting Range		Description
Speed-L	0	Multi-step speed - Low
Speed-M	1	Multi-step speed - Mid
Speed-H	2	Multi-step speed - High
XCEL-L	3	Multi-accel/decel - Low
XCEL-M	4	Multi-accel/decel - Mid
XCEL-H	5	Multi-accel/decel - High
Dc-brake	6	DC injection braking during stop
2nd Func	7	Exchange to 2 <sup>nd</sup> (Motor) function
-Reserved-	8	Reserved for future use
-Reserved-	9	Reserved for future use
Up	10	Acceleration Reference
Down	11	Deceleration Reference
3-Wire	12	3-wire operation
Ext Trip-A	13	External trip A
Ext Trip-B	14	External trip B
-Reserved-	15	Reserved for future use
Open-loop	16	Exchange between PID mode and V/F mode
-Reserved-	17	Reserved for future use
Analog hold	18	Hold the analog input signal
XCEL s~p	19	Disable acceleration and deceleration
-Reserved-	20	Reserved for future use

**[Speed-L, Speed-M, Speed-H]**

By setting S6, S7, S8 terminals to “Speed-L”, “Speed-M” and “Speed-H” respectively, inverter can operate at the preset frequency set in U-05 ~ U-07 and C-20 ~ C-24.

The step frequencies are determined by the combination of S6, S7 and S8 terminals as shown in the following table.

Binary Combination of multi-function terminal S6, S7, S8			The signal source from frequency reference.	Description
Terminal S6-COM	Terminal S7-COM	Terminal S8-COM		
Speed-L	Speed-M	Speed-H		
C-12=0	C-13=1	C-14=2		
0 (off)	0 (off)	0 (off)	<b>U-04</b>	Select frequency reference. (Speed 0)
1 (on)	0 (off)	0 (off)	<b>U-05</b>	Frequency reference 1
0 (off)	1 (on)	0 (off)	<b>U-06</b>	Frequency reference 2
1 (on)	1 (on)	0 (off)	<b>U-07</b>	Frequency reference 3
0 (off)	0 (off)	1 (on)	<b>C-21</b>	Frequency reference 4
1 (on)	0 (off)	1 (on)	<b>C-22</b>	Frequency reference 5
0 (off)	1 (on)	1 (on)	<b>C-23</b>	Frequency reference 6
1 (on)	1 (on)	1 (on)	<b>C-24</b>	Frequency reference 7

C-20 [Jog Frequency] can be used as one of the step frequencies.

If the “S5” terminal is ON, inverter operates to Jog frequency regardless of other terminal inputs when the inverter has input signal on terminal S6, S7, S8.

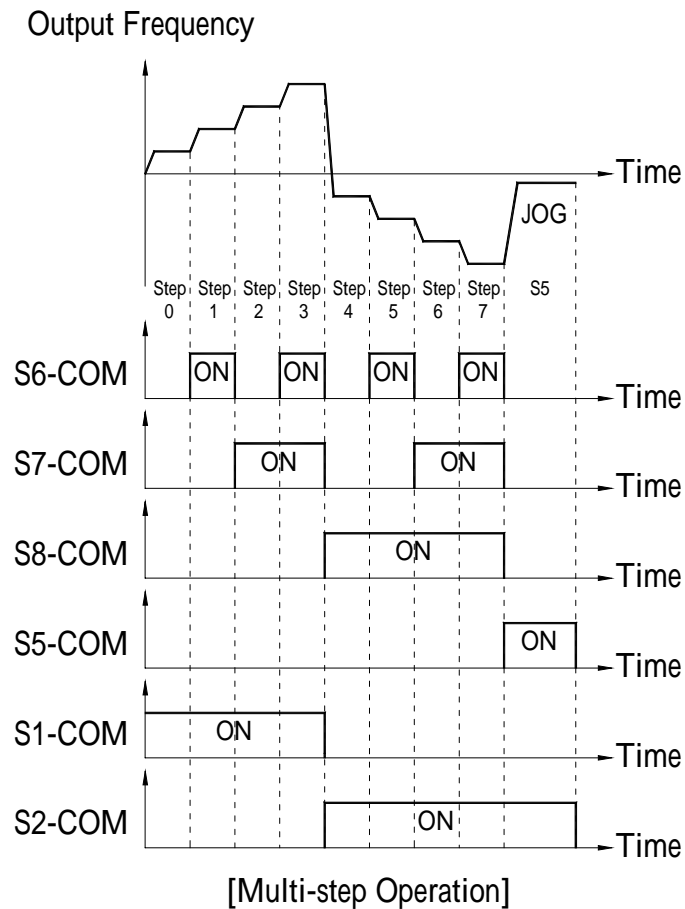

**Related Constants :**  
 U-05 ~ U-07 [Step Frequency]  
 C-20 [S5 Frequency]  
 C-21 ~ C-24 [Step Frequency]

**[XCEL-L, XCEL-M, XCEL-H]**

By setting S6, S7 and S8 terminals to “XCEL-L”, “XCEL-M” and “XCEL-H” respectively, up to 8 different Accel and Decel times can be used. The Accel/Decel time is set in U-01 ~ U-02 and C-25 ~ C-38. The Accel/Decel time is determined by the combination of S6, S7 and S8 terminals as shown in the following table.

Accel/Decel Time	Constant Code	XCEL-H (S8)	XCEL-M (S7)	XCEL-L (S6)
Accel Time-0	U-01	0	0	0
Decel Time-0	U-02	OFF	OFF	OFF
Accel Time-1	C-25	0	0	1
Decel Time-1	C-26	OFF	OFF	ON
Accel Time-2	C-27			

Accel/Decel Time	Constant Code	XCEL-H (S8)	XCEL-M (S7)	XCEL-L (S6)
Decel Time-2	C-28	0 OFF	1 ON	0 OFF
Accel Time-3	C-29	0 OFF	1 ON	1
Decel Time-3	C-30			ON
Accel Time-4	C-31	1 ON	0 OFF	0
Decel Time-4	C-32			OFF
Accel Time-5	C-33	1 ON	0 OFF	1
Decel Time-5	C-34			ON
Accel Time-6	C-35	1 ON	1 ON	0
Decel Time-6	C-36			OFF
Accel Time-7	C-37	1 ON	1 ON	1
Decel Time-7	C-38			ON

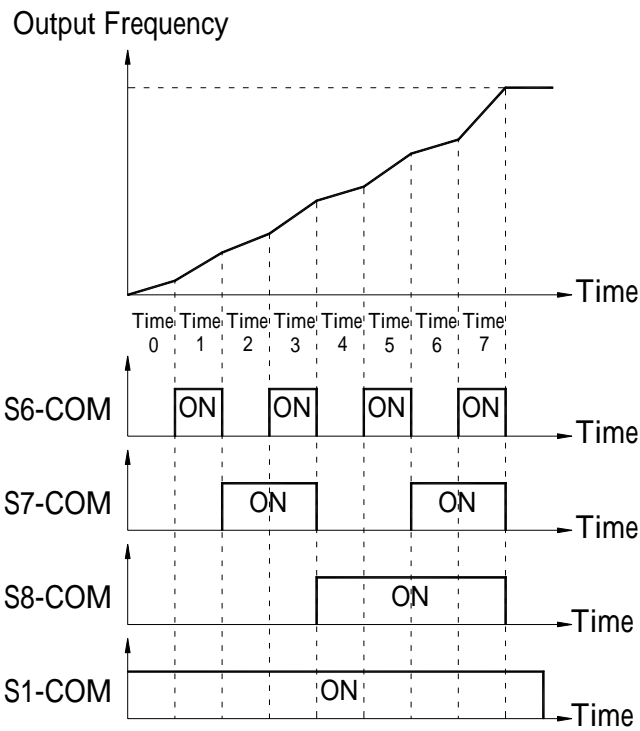

[Multi-accel/decel Time Operation]

**Related Constant :** C-25 ~ C-38 [1<sup>st</sup> ~7<sup>th</sup> Accel/Decel Time]

**[DC-Brake]**

DC Injection Braking can be activated during inverter stopped by configuring one of the multi-function input terminals (S6, S7, S8) to 'DC-Bake'. To activate the DC Injection Braking, close the contact on the assigned terminal while the inverter is stopped.

---

### [2<sup>nd</sup> Function]

Inverter uses constants set in b-81 ~ b-89 when this terminal is ON. This function must be used when motor is stopped to avoid over current or over voltage trip.

### [Up, Down]

By using the Up and Down function, the drive can accelerate to a steady speed and decelerate down to a desired speed by using only two input terminals.

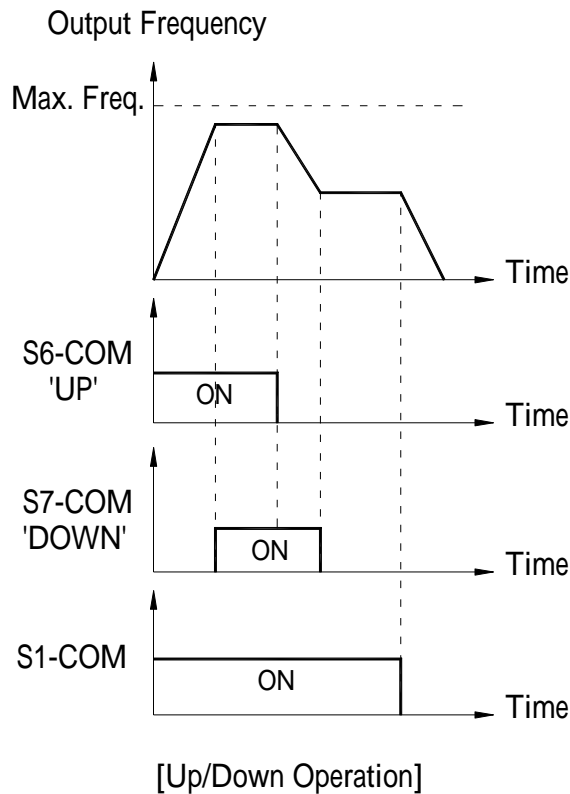

### [3-Wire]

This function is for 3-wire start/stop control.

This function is mainly used with a momentary push button to hold the current frequency output during acceleration or deceleration.

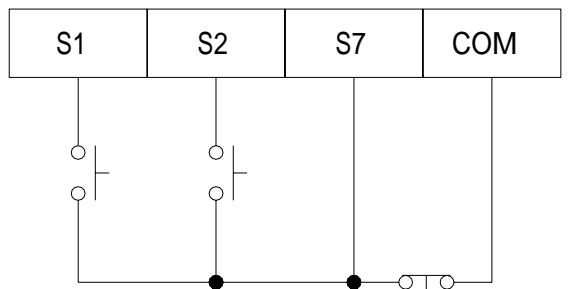

[Wiring for 3-wire Operation, S7 Set to '3-wire']

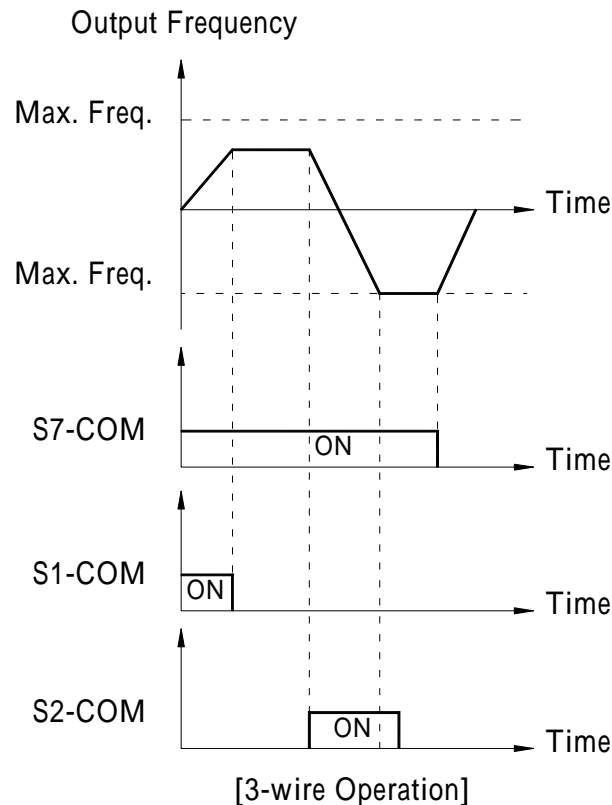

**[Ext Trip-A]**

This is a normally open contact input. When a terminal set to “Ext Trip-A” is ON, inverter displays the fault (EF2) and cuts off its output. This can be used as an external latch trip.

**[Ext Trip-B]**

This is a normally closed contact input. When a terminal set to “Ext Trip-B” is OFF, inverter displays the fault (EF3) and cuts off its output. This can be used as an external latch trip.

**[Open-Loop]**

This is used to exchange the control mode of inverter from PID mode (Close Loop) to V/F mode (Open Loop). U-03 [Drive Mode] and U-04 [Frequency Mode] are applied when the mode has been changed to V/F pattern.

This function can be used only when the inverter is stopped.

**[Analog Hold]**

When there is an analog input signal for frequency reference and “Analog hold” terminal is ON, inverter fixes its output frequency regardless of the frequency reference setting value. The output frequency will be desired value by frequency reference when the terminal is OFF. This function is useful when a system requires constant speed after acceleration.

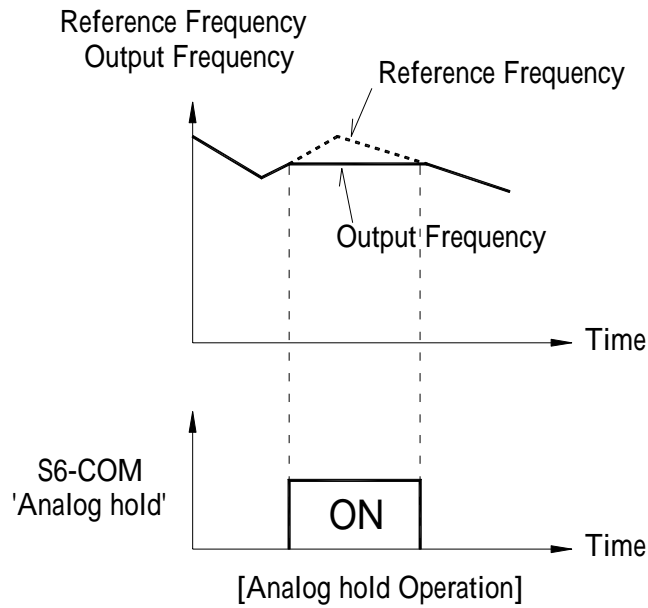

C-15 : Terminal Input Status  
C-16 : Terminal Output Status

C-15 displays the input status of control terminals (S1~S8).

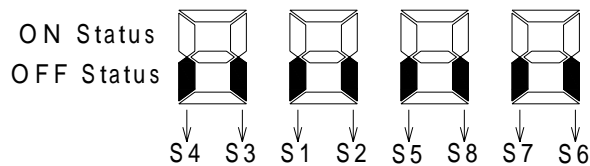

C-16 displays the output status of multi-function M1-M2 for control terminals

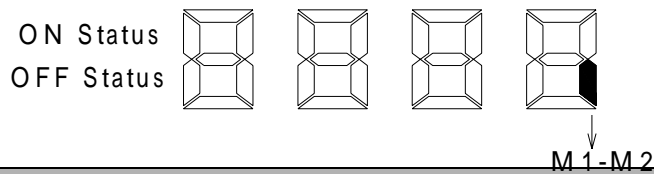

C-17 : Filtering Time Constant for Multi-function Input Terminals

This is the response time constant for terminal inputs (S1, S2, S3, S4, S5, S6, S7, S8). This is useful where there is a potential for noise. The response time is determined by "Filtering time constant \* 0.5msec".

C-20 : Jog Frequency

This code sets the Jog frequency. See [Speed-L, Speed-M, Speed-H] in C-12 ~ C-14.

---

C-21 : Step Frequency 4  
C-22 : Step Frequency 5  
C-23 : Step Frequency 6  
C-24 : Step Frequency 7

These codes set the 4<sup>th</sup> ~ 7<sup>th</sup> step frequency. See [Speed-L, Speed-M, Speed-H] in C-12 ~ C-14.

**Related Constants :**

U-05 ~ U-07 [Step Frequency 1 ~ 3]  
C-12 ~ C-14 [Multi-function inputs]  
C-17 [Filtering Time Constant]

C-25~ C-38 : 1<sup>st</sup> ~ 7<sup>th</sup> Accel/Decel Time

These codes are applied when the multi-function input terminals (S6, S7, S8) select the Accel/Decel time. See [XCEL-L, XCEL-M, XCEL-H] in C-12 ~ C-14.

**Related Constants :**

U-01 ~ U-02 [Accel/Decel Time]  
b-70 [Reference Freq. for Accel/Decel]  
b-71 [Accel/Decel Time Scale]  
C-12 ~ C-14 [Multi-function inputs]

C-40 : FM-FC (Frequency Meter) Output Selection

C-41 : FM-FC Output Gain

FM-FC terminal displays the inverter output frequency, output current, output voltage and DC link voltage. FM-FC output voltage range from 0V to 10V. C-41 is used to adjust the output gain.

**[Output Frequency]**

FM terminal outputs inverter output frequency. The output value is determined by,  
FM Output Voltage = (Output freq. / Max. output freq.) × 10V × C-41 / 100

**[Output Current]**

FM terminal outputs output current of the inverter. The output value is determined by,  
FM Output Voltage = (Present output current / Motor rated current) × 10V × C-41 / 100

**[Output Voltage]**

FM terminal outputs output voltage of inverter.. The output value is determined by,  
FM Output Voltage = (Present output voltage / Max. output voltage) × 10V × C-41 / 100

---

**[DC Link Voltage]**

FM terminal outputs the DC link voltage of inverter. The output value is determined by,  
FM Output Voltage = (DC link voltage / Max. DC link voltage) × 10V × C-41 / 100

VDC max. = 400V at 220V class ; VDC max. = 800V at 440V class

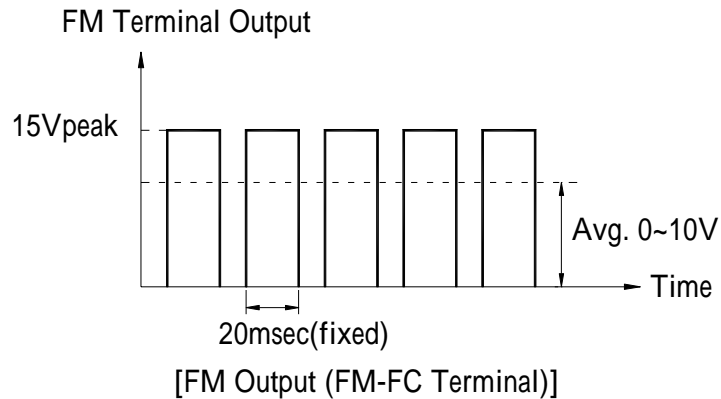

C-42 : FDT (Frequency Detection) Level

C-43 : FDT Bandwidth

These functions are used in C-44 [Multi-function Output Terminal M1-M2 Selection]. See [FDT-#] in C-44.

**Related Constant :** C-44 [Multi-function Output Define M1-M2 Selection]

C-44 : Multi-function Output define (MO-MG)

The output terminal M1-M2 is closed when the defined condition occurs.

Setting Range		Description
FDT-1	0	Output frequency arrival frequency reference.
FDT-2	1	Output frequency = setting frequency of C-42
FDT-3	2	Refer to the drawing description.
FDT-4	3	
FDT-5	4	
OL1	5	Motor overload trip
OL2	6	Inverter overload trip
Stall	7	Stall prevention mode detection
OV	8	Over voltage detection
UV	9	Low voltage detection
OH	10	Overheat detection
Lost Command	11	Lost frequency command detection
Run	12	Inverter running detection
Stop	13	Inverter stop detection
Steady	14	Steady speed detection
Ssearch	17	Speed search mode detection
Ready	20	Inverter in ready status to run

**[FDT-1]**

When the output frequency reaches the reference frequency (target frequency), M1-M2 terminal is CLOSED.

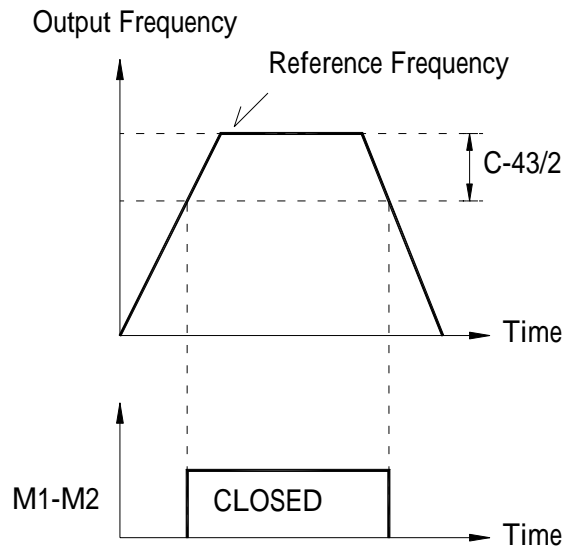

[C-44=0(FDT-1)]

**[FDT-2]**

M1-M2 is CLOSED when the output frequency is in C-43 [FDT Bandwidth] centered on C-42 [FDT Frequency].

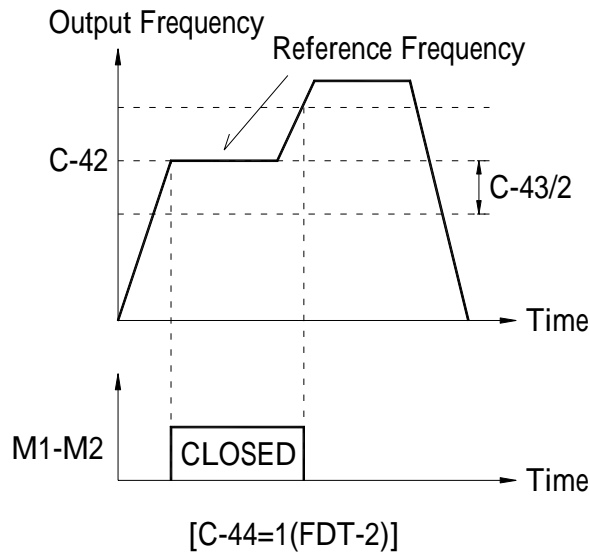

**[FDT-3]**

M1-M2 is CLOSED when the output frequency reaches the band centered on the C-44=1 (FDT-2), C-42 [FDT frequency]. The output is OPENED when the output frequency goes outside the C-43 [FDT bandwidth] centered on the C-42 [FDT frequency].

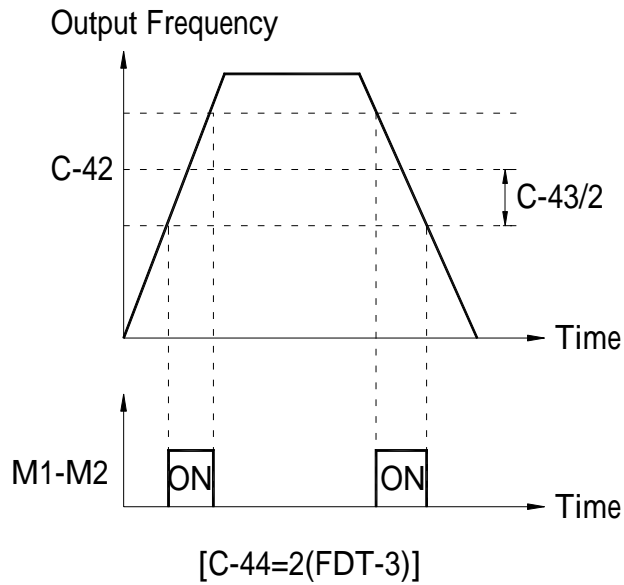

---

**[FDT-4]**

M1-M2 is CLOSED when the output frequency reaches the C-44=2 [FDT frequency]. The output is OPENED when the output frequency goes below the FDT bandwidth centered on the C-42 [FDT frequency].

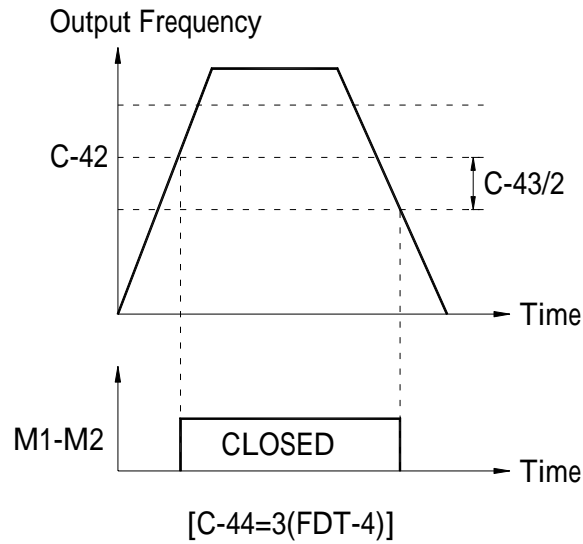

**[FDT-5]**

This is the inverted output of [FDT-4].

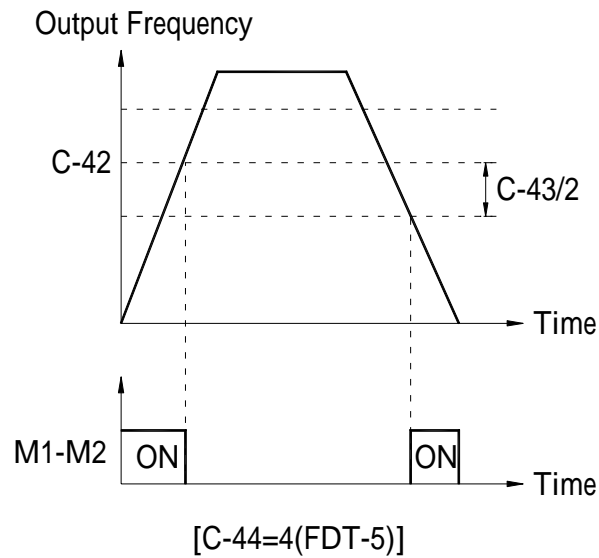

---

**[OL1] Motor Overload Trip**

M1-M2 is CLOSED when the output current has reached the A-54 [Overload Warning Level] and A-55 [Overload Warning Time].

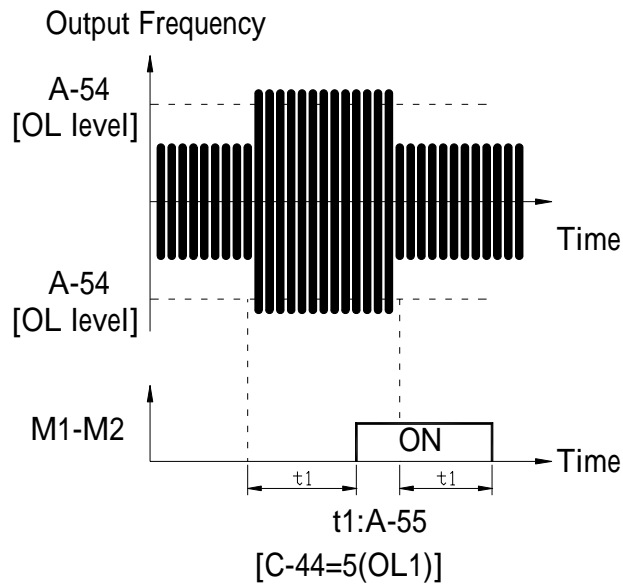

**[IOL] Inverter Overload Trip**

M1-M2 is CLOSED when the output current is above the 150% of rated inverter current for 36 seconds. If this situation is continued for one minute, the inverter will cut off its output and displays “OL2” (Inverter overload trip). Please refer to EI-500 catalog for the rated inverter current.

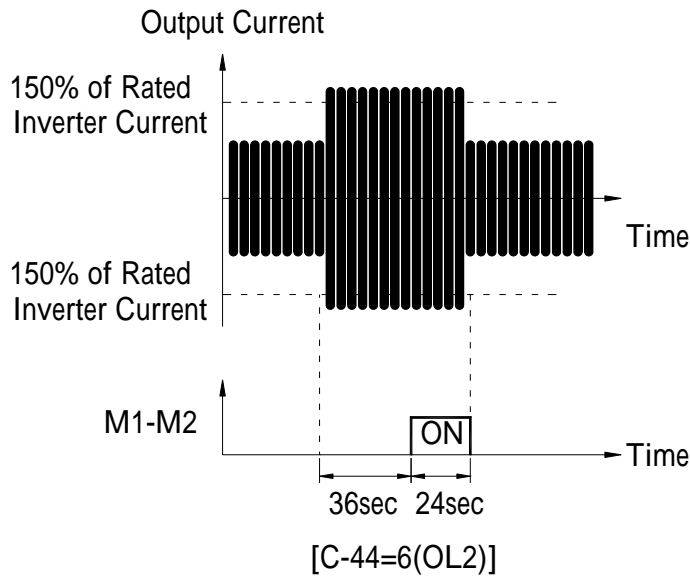

---

**[Stall] Stall Prevention Mode**

M1-M2 is CLOSED when the inverter is on the stall prevention mode.

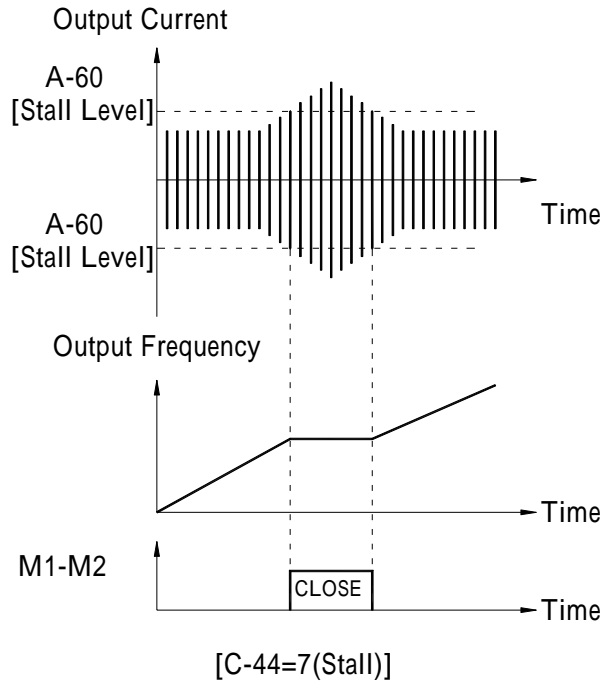

**[OV] Overload Detection**

M1-M2 is CLOSED when the DC link voltage is above the Over-voltage level.

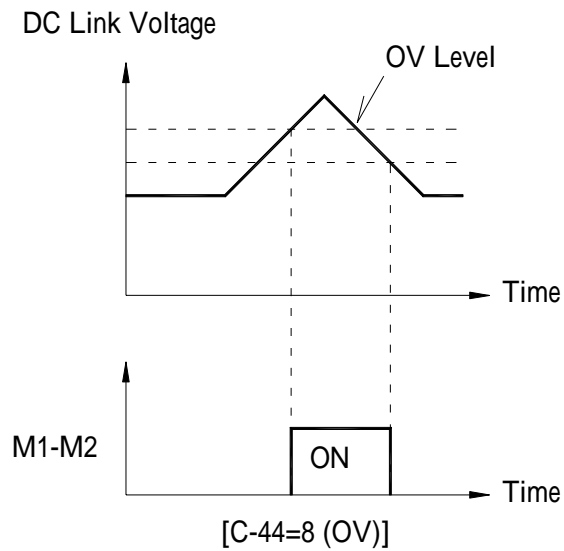

---

**[UV] Under Voltage Detection**

M1-M2 is CLOSED when the DC link voltage is below the Low-voltage level.

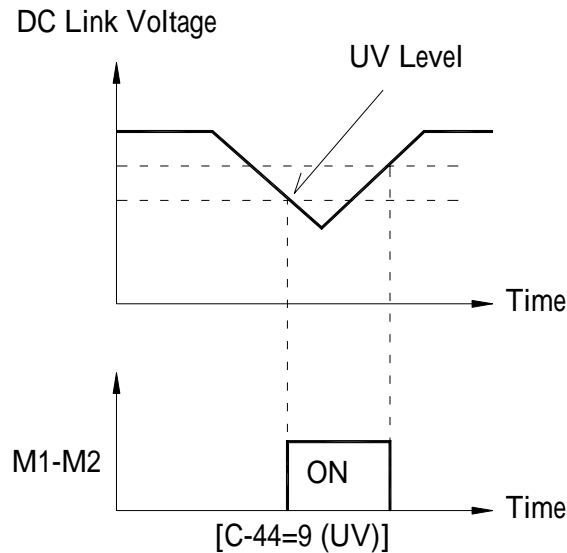

**[OH] Heat Sink Overheat**

M1-M2 is CLOSED when the heat sink of the inverter is above the 75 .

**[Lost Command] Frequency Reference Loss Detection**

M1-M2 is CLOSED when frequency reference is lost.

**[Run] Inverter Running Detection**

M1-M2 is CLOSED when the inverter is running.

**[Stop] Inverter Stop Detection**

M1-M2 is CLOSED when the inverter is stopped.

**[Steady] Stead Speed Detection**

M1-M2 is CLOSED when the inverter in steady speed status.

**[Search] Speed Search Detection**

M1-M2 is CLOSED when the inverter is speed searching.

**[Ready] Inverter Ready Detection**

M1-M2 is CLOSED when the inverter is ready to run.

---

**C-45 : Fault Output Relay (MA, MB, MC)**

This function is used to allow the fault output relay to operate when a fault occurs. The output relay terminal is MA, MB, MC where MA-MC is a normally open contact and MB-MC is a normally closed contact.

Bit	Setting	Display	Description
Bit 0 (Uv)	0	000	Fault output relay does not operate at “Under voltage” trip.
	1	001	Fault output relay operates at “Under voltage” trip.
Bit 1 (Trip)	0	000	Fault output relay does not operate at any fault.
	1	010	Fault output relay operates at any fault except “Under voltage” and “S3” (inverter emergency stop ) fault.
Bit 2 (Retry)	0	000	Fault output relay does not operate regardless of the retry number.
	1	100	Fault output relay operates when the retry number set in b-26 decreases to 0 by faults.

When several faults occur at the same time, Bit 0 has the first priority.

**C-46 : Inverter Number****C-47 : Baud Rate**

[C-46] : This code sets the inverter number. This number is used in communication between inverter and PLC (Programmable Logic Controller).

[C-47] : This code sets the inverter communication speed. This is used in communication between inverter and PLC (Programmable Logic Controller).

**C-48 : Operating at Loss of Freq. Reference****C-49 : Waiting Time after Loss of Freq. Reference**

There are two kinds of loss of frequency reference. One is the loss of digital frequency reference and the other is of analog frequency reference.

Loss of digital frequency reference is applied when U-04=0 or U-04=1. At this time, the “Loss” means the communication error between inverter and digital operator RCU-500.

Loss of analog frequency reference is applied when U-04=2, 3, 4. At this time, the “Loss” is determined by the criteria set in C-11 [Criteria for Analog Input Signal Loss].

Setting Range		Description
<b>C-48</b>	0 (Factory Default)	Inverter keeps on operating at the previous frequency.
	1 Free Run (Coast to stop)	Inverter cuts off its output.
	2 Stop	Inverter stops with Decel time (U-02) and Decel pattern (A-26).

[C-49] : This is the time the inverter determines whether there is a frequency reference or not. If there is no frequency reference satisfying C-11 during this time, inverter determines that it has loss of frequency reference signal.

C-99 : Return to Function Group C

## CHAPTER FIVE TROUBLESHOOTING AND MAINTENANCE





### Fault Display

When a fault occurs, the inverter turns off its output and displays the fault status in U-12. The last 5 faults are saved in b-01 through b-05 with the operation status at the instance of fault.

Display	Protective Function	Description
<b>OC</b>	Over Current Protection	The inverter turns off its output when the output current of the inverter flows more than 200% of the inverter rated current.
<b>OU</b>	Over Voltage Protection	The inverter turns off its output if the DC voltage of the main circuit increases higher than the rated value when the motor decelerates or when regenerative energy flows back to the inverter due to a regenerative load. This fault can also occur due to a surge voltage generated at the power supply system.
<b>OL1</b>	Motor Overload Trip	The inverter turns off its output if the output current of the inverter flows at 180% of the inverter rated current for more than the current limit time.
<b>OH</b>	Heat Sink Over Heat	The inverter turns off its output if the heat sink over heats due to a damaged cooling fan or an alien substance in the cooling fan by detecting the temperature of the heat sink.
<b>ETH</b>	Electronic Thermal Protection	The internal electronic thermal of the inverter determines the over heating of the motor. If the motor is overloaded the inverter turns off the output. The inverter cannot protect the motor when driving a multi-pole motor or when driving multiple motors, so consider thermal relays or other thermal protective devices for each motor. Overload capacity: 150% for 1 min
<b>UV</b>	Under Voltage Protection	The inverter turns off its output if the DC voltage is below the detection level. Insufficient torque or over heating of the motor can occurs when the input voltage of the inverter drops.
<b>PF</b>	Input Phase Open	The inverter turns off the output when one or more of the input(R/L1, S/L2, T/L3) phase is open and the output load is over 50% of the inverter rated current for more than 1 minute. The inverter checks whether the phase is open by detecting the DC voltage of the main circuit.
<b>LF</b>	Output Phase Open	The inverter turns off its output when the one or more of the output (U/T1, V/T2, W/T3) phase is open. The inverter detects the output current to check the phase open of the output.
<b>EF1</b>	Emergency Stop (S3 Terminal ON)	Used for the emergency stop of the inverter. The inverter instantly turns off the output when the S3 terminal is turned ON, and returns to regular operation when the S3 terminal is turned OFF. Take caution when using this function.
<b>OL2</b>	Inverter Overload Trip	The inverter turns off its output when the output current of the inverter flows more than the rated level (150% for 1 minute-Inversely proportional to time).

Display	Protective Function	Description
EF2	External Fault A	Use this function if the user needs to turn off the output by an external fault signal. (Normal Open Contact)
EF3	External Fault B	Use this function if the user needs to turn off the output by an external fault signal. (Normal Close Contact)
LOSt	Operating Method when the Frequency Reference is Lost	According to C-48 [Operating Method when the Frequency Reference is Lost], there are 3 modes: continue operation, decelerate and stop, and free run.
Err1	EEPROM Error 1	The digital operator RCU-500 EEPROM has a fault causing parameter read/write error.
Err2	EEPROM Error 2	The ROM version for the inverter and digital operator RCU-500 are different.
[PF5]	Inverter H/W Fault	When an error occurs to the control circuitry of the inverter a fault signal is sent. There are the CPU error, the EEPROM error, Fan Fault, Ground Fault and NTC Damage for this fault
[PF4]	CPU Error	The CPU has a fault.
[PF3]	EEPROM Error	The EEPROM on inverter main board has a fault.
FRn	Fan fault	The cooling fan does not rotate.
GF	Ground Fault	A ground fault occurs. Inverter checks ground fault only when power is ON and run command is entered.
ntC	NTC Damage	NTC is damaged.

Inverter outputs voltage for 20msec to check Ground Fault.

[PF5] is displayed when FRn, [PF3], [PF4], GF, ntC faults occur. Use , , ,  keys to see the detailed fault contents.

Operating method and fault display when frequency reference is lost

■ C-48 [Operating Method when Frequency Reference is Lost]

C-48 Setting	Function Description
0 (None)	Continues operation when the frequency reference is lost (Factory Default)
1 (FreeRun)	Free runs and stops when the frequency reference is lost.
2 (Stop)	Decelerates and stops when the frequency reference is lost.





■ Digital operator RCU-500 display when analog frequency reference is lost

Keypad Display	Contents
<b>LOSt</b>	Displayed when Vs analog frequency reference is lost.
<b>LOSt</b>	Displayed when Is analog frequency reference is lost.

■ Fault contents and operating status prior to fault

1) Present Fault Contents (Ex : Over Current)

Code	Display	Description
<b>U-12</b>	<b>OC</b>	Displays the present fault contents (Over current)

Check the fault contents before pressing the reset key. Press the  key and then use the ,  keys to check the operating information (output frequency, output current, acceleration, deceleration, constant speed status) prior to fault. Press the  key to exit. The inverter will store the fault contents to the memory in b-01 when the  key is pressed.

2) Fault History Contents

b-01~b-05 [Fault history] has the 5 most current faults in its memory. The smallest number will be the most current fault in its memory. Check the operating information prior to fault.

Constants Code	Display	Description
b-01	Last trip-1	Fault history 1
b-02	Last trip-2	Fault history 2
b-03	Last trip-3	Fault history 3
b-04	Last trip-4	Fault history 4
b-05	Last trip-5	Fault history 5

The b-06 [Erase Fault History] erases b-01~b-05 [Fault History] contents from the memory, and returns the contents to the factory default status.

## Fault (Inverter Fault) Reset

There are 3 ways to reset the inverter. The auto retry number will be initialized when the user resets the inverter.

- 1) Reset by using the  key of the digital operator.
- 2) Reset by shorting the S4-COM terminals on the control terminals.
- 3) Turn OFF the inverter and turn the inverter back ON.

## Fault Remedy

Protective Function	Cause	Remedy
Over Current Protection	<ol style="list-style-type: none"> <li>1) Acceleration/Deceleration time is too short compared to the <math>GD^2</math> of the load.</li> <li>2) Load is larger than the inverter rating.</li> <li>3) Inverter turns output on while motor is free running.</li> <li>4) Output short or ground fault has occurred.</li> <li>5) Mechanical brake of the motor is operating too fast.</li> <li>6) Components of the main circuit are overheated due to a faulty cooling fan.</li> </ol>	<ol style="list-style-type: none"> <li>1) Increase Accel/Decel time.</li> <li>2) Increase inverter capacity.</li> <li>3) Operate after motor has stopped.</li> <li>4) Check output wiring.</li> <li>5) Check mechanical brake operation.</li> <li>6) Check cooling fan.</li> </ol> <p><b>(Caution)</b> Operating prior to correcting fault may damage the IGBT.</p>
Over Voltage Protection	<ol style="list-style-type: none"> <li>1) Deceleration time is too short compared to the load.</li> <li>2) Regenerative load on inverter output.</li> <li>3) Line voltage is too high.</li> </ol>	<ol style="list-style-type: none"> <li>1) Increase deceleration time.</li> <li>2) Use regenerative resistor option.</li> <li>3) Check line voltage.</li> </ol>
Motor Overload Trip	<ol style="list-style-type: none"> <li>1) Load is larger than inverter rating.</li> <li>2) User selected incorrect inverter capacity.</li> <li>3) User set incorrect V/F pattern.</li> </ol>	<ol style="list-style-type: none"> <li>1) Increase capacity of motor and inverter.</li> <li>2) Select a correct inverter capacity.</li> <li>3) Select correct V/F pattern.</li> </ol>
Heat Sink Overheat	<ol style="list-style-type: none"> <li>1) Cooling fan is damaged or an alien substance is inserted.</li> <li>2) Cooling system has a fault.</li> <li>3) Ambient temperature too high.</li> </ol>	<ol style="list-style-type: none"> <li>1) Exchange cooling fans and/or eliminate alien substance.</li> <li>2) Check for any alien substances in heat sink.</li> <li>3) Keep ambient temperature under 40 °C.</li> </ol>
Electronic Thermal	<ol style="list-style-type: none"> <li>1) Motor has overheated.</li> <li>2) Load is larger than inverter rating.</li> <li>3) ETH level too low.</li> <li>4) User selected incorrect inverter capacity.</li> <li>5) User set incorrect V/F pattern.</li> <li>6) Operating too long at low speeds.</li> </ol>	<ol style="list-style-type: none"> <li>1) Reduce load and/or running duty.</li> <li>2) Increase inverter capacity.</li> <li>3) Adjust ETH level to an appropriate level.</li> <li>4) Select a correct inverter capacity.</li> <li>5) Select a correct V/F pattern.</li> <li>6) Install a cooling fan with a separate blower.</li> </ol>
Under Voltage Protection	<ol style="list-style-type: none"> <li>1) Line voltage too low.</li> <li>2) Load larger than line capacity connected to input. (Welding machine, motor with high starting current connected to the commercial line)</li> <li>3) Damaged or faulty magnetic switch at input side of inverter.</li> </ol>	<ol style="list-style-type: none"> <li>1) Check line voltage.</li> <li>2) Increase <b>wire</b>.</li> <li>3) Exchange magnetic switch.</li> </ol>

Protective Function	Cause	Remedy
Output Phase Open	<ol style="list-style-type: none"> <li>1) Faulty contact on the magnetic switch at the output.</li> <li>2) Faulty output wiring</li> </ol>	<ol style="list-style-type: none"> <li>1) Check magnetic switch on output.</li> <li>2) Check output wiring.</li> </ol>
Inverter H/W Fault	<ol style="list-style-type: none"> <li>1) Fan Fault</li> <li>2) CPU Error</li> <li>3) EEPROM Error</li> <li>4) Ground Fault</li> <li>5) NTC Damage</li> </ol>	<ol style="list-style-type: none"> <li>1) Check cooling fan.</li> <li>2) Exchange inverter.</li> <li>3) Exchange inverter.</li> <li>4) Check inverter, motor, and wiring insulation.</li> <li>5) Check NTC.</li> </ol>
LOV (Vs) LOI (I)	Frequency Reference is Lost	Eliminate cause of fault.
Inverter Overload	<ol style="list-style-type: none"> <li>1) Load is larger than inverter rating.</li> <li>2) User selected incorrect inverter capacity.</li> </ol>	<ol style="list-style-type: none"> <li>1) Increase motor and/or inverter capacity.</li> <li>2) Select correct inverter capacity.</li> </ol>

## Troubleshooting

Condition	Check Point
The motor does not rotate	1) Main circuit inspection <ul style="list-style-type: none"> <li>➤ Input (line) voltage normal? (LED charge lamp on?)</li> <li>➤ Motor connected correctly?</li> </ul> 2) Input signal inspection <ul style="list-style-type: none"> <li>➤ Input signal to inverter functioning?</li> <li>➤ Forward and reverse signals inputted simultaneously to inverter?</li> <li>➤ Inverter receiving command input frequency signal?</li> </ul> 3) Parameter setting inspection <ul style="list-style-type: none"> <li>➤ Reverse prevention (A-03) function set?</li> <li>➤ Operation mode (A-01) set correctly?</li> <li>➤ Frequency reference set to successfully?</li> </ul> 4) Load inspection <ul style="list-style-type: none"> <li>➤ Is the load too large, or is the motor capacity too small?</li> </ul>
The motor rotates in opposite directions	<ul style="list-style-type: none"> <li>➤ Phase sequence of output terminal U/T1, V/T2 and W/T3 correct?</li> <li>➤ Starting signal (Forward/Reverse) connected correctly?</li> </ul>
The difference between the rotating speed and the reference is too big	<ul style="list-style-type: none"> <li>➤ Reference frequency verified? (Check the level of input signal)</li> <li>➤ Following parameter setting verified?</li> <li>➤ Lower Limit Frequency (A-24), Upper Limit Frequency (A-25), Analog Frequency Gain (C-01~C-10)</li> <li>➤ External noise? (Use a shielded wire)</li> </ul>
The inverter does not accelerate or decelerate smoothly	<ul style="list-style-type: none"> <li>➤ Acceleration/Deceleration time too short?</li> <li>➤ Load too large?</li> <li>➤ Torque Boost (A-27, A-28) value too high? (Current limit function and the stall prevention function verified?)</li> </ul>
The motor current is too high	<ul style="list-style-type: none"> <li>➤ Load too large?</li> <li>➤ Torque Boost Value (manual) too high?</li> </ul>
The rotating speed does not increase	<ul style="list-style-type: none"> <li>➤ Upper Limit Frequency (A-25) value correct?</li> <li>➤ Load too large?</li> <li>➤ Torque Boost (A-27, 28) value too high? Is Stall prevention function (A-59, A-60) verified?</li> </ul>
The rotating speed oscillates when the inverter is operating.	1) Load inspection <ul style="list-style-type: none"> <li>➤ Load oscillating?</li> </ul> 2) Input signal inspection <ul style="list-style-type: none"> <li>➤ Reference frequency signal oscillating?</li> </ul> 3) Other <ul style="list-style-type: none"> <li>➤ Wiring too long? (Over 100m)</li> </ul>

## Check Power Components (IGBT)

Before checking the power components, be sure to disconnect AC input supply and wait until the Main Electrolytic Capacitors are discharged to safe voltage levels.

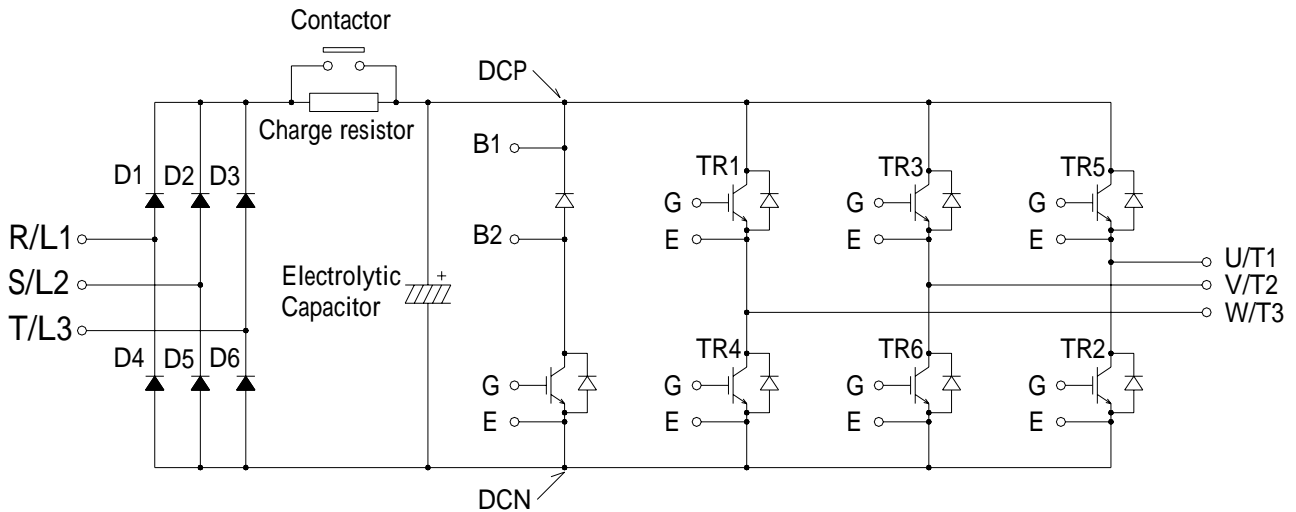

- 1) Disconnect the power input line (R/L1, S/L2, T/L3) and the inverter output to the motor (U/T1, V/T2, W/T3).
- 2) Verify whether the inverter terminal R/L1, S/L2, T/L3, U/T1, V/T2, W/T3, P, PR is shorted or open by changing the polarity of the tester.
- 3) Verify capacitor has discharged before testing.
- 4) The tester should display several mega-ohms when open. The tester can display terminal is shorted for a short time and then display several mega-ohms because of the electrolytic capacitor. The tester should display  $1\ \Omega \sim 10\ \Omega$  when terminal is shorted. If all measured values are about the same, individual modules are OK.
- 5) Diode module and IGBT module checking points:

Elements		Test Polarity		Measured Value	Element	Test Polarity		Measured Value
		+	-			+	-	
Diode Module	D1	R	P	Short	D4	R	DCN	Open
		P	R	Open		DCN	R	Short
	D2	S	P	Short	D5	S	DCN	Open
		P	S	Open		DCN	S	Short
	D3	T	P	Short	D6	T	DCN	Open
		P	T	Open		DCN	T	Short
IGBT Module	Tr1	U	P	Short	Tr4	U	DCN	Open
		P	U	Open		DCN	U	Short
	Tr3	V	P	Short	Tr6	V	DCN	Open
		P	V	Open		DCN	V	Short
	Tr5	W	P	Short	Tr2	W	DCN	Open
		P	W	Open		DCN	W	Short

### Precautions

- Be sure to remove the drive power input while performing maintenance.
- Be sure to perform maintenance only after checking that the DC bus has discharged. The bus capacitors in the electronic circuit can still be charged even after the power is turned off.
- The correct output voltage can only be measured by using a rectifier voltage meter. Other voltage meters including digital voltage meters are likely to display incorrect values caused by the high frequency PWM output voltage of the inverter.

### Routine Inspection

Be sure to check the following before operation.

- The conditions of the installation location.
- The conditions of the inverter cooling.
- Abnormal vibration.
- Abnormal heating.

### Periodical Inspection

- Any loose bolt, nut or rust caused by surrounding conditions?  
If so, tighten up or replace.
- Any deposits inside of the drive of cooling fan?  
If so, remove the deposits using air.
- Any deposit on the inverter's PCB (Printed Circuit Boards)?  
If so, remove the deposits using air.
- Any abnormal contacts in the various connectors of the inverter's PCB?  
If so, check the condition of the connector in question.
- Check the rotating condition of the cooling fan, the size and condition of the capacitors and the connections with the magnetic contactor.  
Replace it if there is any abnormality.