

EI-550 Series

220V Class 1HP~10HP

440V Class 1HP~10HP

Read this manual carefully before installing, wiring,
operating, servicing or inspecting the drive.
Keep this manual within easy reach for quick reference.

RICH
ELECTRIC

RICH ELECTRIC CO., LTD.

Thank you for purchasing Eric-550 Variable Speed Drives!

SAFETY INSTRUCTIONS

- Always follow safety instructions to prevent accidents and potential hazards from occurring.

- In this manual, safety messages are classified as follows:



WARNING Improper operation may result in serious personal injury or death.



CAUTION Improper operation may result in slight to medium personal injury or property damage.

- Throughout this manual we use the following two illustrations to make you aware of safety considerations:



Identifies potential hazards under certain conditions.
Read the message and follow the instructions carefully.



Identifies shock hazards under certain conditions.
Particular attention should be directed because dangerous voltage may be present.

- Keep operating instructions handy for quick reference.
- Read this manual carefully to maximize the performance of EI-550 series inverter and ensure its safe use.



WARNING

- **Do not remove the cover while power is applied or the unit is in operation.**
Otherwise, electric shock could occur.
- **Do not run the inverter with the front cover removed.**
Otherwise, you may get an electric shock due to high voltage terminals or charged capacitor exposure.
- **Do not remove the cover except for periodic inspections or wiring, even if the input power is not applied.**
Otherwise, you may access the charged circuits and get an electric shock.

-
- **Wiring and periodic inspections should be performed at least 10 minutes after disconnecting the input power and after checking the DC link voltage is discharged with a meter (below DC 30V).**
Otherwise, you may get an electric shock.
 - **Operate the switches with dry hands.**
Otherwise, you may get an electric shock.
 - **Do not use the cable when its insulating tube is damaged.**
Otherwise, you may get an electric shock.
 - **Do not subject the cables to scratches, excessive stress, heavy loads or pinching.**
Otherwise, you may get an electric shock.



CAUTION

- **Install the inverter on a non-flammable surface. Do not place flammable material nearby.**
Otherwise, fire could occur.
- **Disconnect the input power if the inverter gets damaged.**
Otherwise, it could result in a secondary accident and fire.
- **After the input power is applied or removed, the inverter will remain hot for a couple of minutes.**
Otherwise, you may get bodily injuries such as skin-burn or damage.
- **Do not apply power to a damaged inverter or to an inverter with parts missing even if the installation is complete.**
Otherwise, electric shock could occur.
- **Do not allow lint, paper, wood chips, dust, metallic chips or other foreign matter into the drive.**
Otherwise, fire or accident could occur.

OPERATING PRECAUTIONS

(1) Handling and installation

- Handle according to the weight of the product.
- Do not stack the inverter boxes higher than the number recommended.
- Install according to instructions specified in this manual.
- Do not open the cover during delivery.

-
- Do not place heavy items on the inverter.
 - Check the inverter mounting orientation is correct.
 - Do not drop the inverter, or subject it to impact.
 - Use the Type 3 grounding method for 220 V Class and special Type 3 for 440V class. (Ground impedance: Below 100 ohm).
 - Take protective measures against ESD (Electrostatic Discharge) before touching the PCB for inspection or installation.
 - Use the inverter under the following environmental conditions:

Environment	Ambient temperature	- 10 ~ +50°C (non-freezing)
	Relative humidity	90% RH or less (non-condensing)
	Storage temperature	- 20 ~ +60°C
	Location	Protected from corrosive gas, combustible gas, oil mist or dust
	Altitude, Vibration	Max. 1,000m above sea level, Max. 9.8m/sec ² (1.0G) or less

(2) Wiring

- Do not connect a power factor correction capacitor, surge suppressor, or RFI filter to the output of the inverter.
- The connection orientation of the output cables U, V, W to the motor will affect the direction of rotation of the motor.
- Incorrect terminal wiring could result in the equipment damage.
- Reversing the polarity (+/-) of the terminals could damage the inverter.
- Only authorized personnel familiar with RICH ELECTRIC inverter should perform wiring and inspections.
- Always install the inverter before wiring. Otherwise, you may get an electric shock or have bodily injury.

(3) Trial run

- Check all parameters during operation. Changing parameter values might be required depending on the load.
- Always apply permissible range of voltage to the each terminal as indicated in this manual. Otherwise, it could lead to inverter damage.

(4) Operation precautions

- When the Auto restart function is selected, stay away from the equipment as a motor will restart suddenly after an alarm stop.
- The “**Stop**” key on the keypad is valid only when the appropriate function setting has been made. Prepare an emergency stop switch separately.

-
- If an alarm reset is made with the reference signal present, a sudden start will occur. Check that the reference signal is turned off in advance. Otherwise an accident could occur.
 - Do not modify or alter anything inside the inverter.
 - Motor might not be protected by electronic thermal function of inverter.
 - Do not use a magnetic contactor on the inverter input for frequent starting/stopping of the inverter.
 - Use a noise filter to reduce the effect of electromagnetic interference. Otherwise nearby electronic equipment may be affected.
 - In case of input voltage unbalance, install AC reactor. Power factor capacitors and generators may become overheated and damaged due to potential high frequency noise transmitted from inverter.
 - Use an insulation-rectified motor or take measures to suppress the micro surge voltage when driving 440V class motor with inverter. A micro surge voltage attributable to wiring constant is generated at motor terminals, and may deteriorate insulation and damage motor.
 - Before operating unit and prior to user programming, reset user parameters to default settings.
 - Inverter can easily be set to high-speed operations, verify capability of motor or machinery prior to operating unit.
 - Stopping torque is not produced when using the DC-Break function. Install separate equipment when stopping torque is needed.

(5) Fault prevention precautions

- Provide a safety backup such as an emergency brake which will prevent the machine and equipment from hazardous conditions if the inverter fails.

(6) Maintenance, inspection and parts replacement

- Do not conduct a megger (insulation resistance) test on the control circuit of the inverter.
- Refer to Chapter 5 for periodic inspection (parts replacement).

(7) Disposal

- Handle the inverter as an industrial waste when disposing of it.

(8) General instructions

- Many of the diagrams and drawings in this instruction manual show the inverter without a circuit breaker, a cover or partially open. Never run the inverter like this. Always place the cover with circuit breakers and follow this instruction manual when operating the inverter.

CONTENTS

USER GUIDE	2
CHAPTER 1 INSTALLATION	10
■ Inspection.....	10
■ Environmental Conditions	10
■ Mounting.....	10
■ Other Precautions	11
■ Dimension	12
■ Standard Wiring	14
■ Terminal Description	15
■ Precautions on Wiring.....	16
■ Grounding.....	16
■ Wiring and Terminal Screw Sizes.....	18
■ Control Terminals.....	20
CHAPTER 2 TEST RUN	23
■ Test Run.....	23
■ Digital Operator (RCU-550) User Instruction	24
■ LCD Display and User Instruction.....	25
■ Multi-function Monitor Items.....	26
■ Constants Selection and Setting.....	27
■ Simple Run Setting	28
■ LOCAL/REMOTE Selection	29
■ Switching Chinese/English Display	30
CHAPTER 3 CONSTANTS LIST	31
■ Primary Function (Constants F001-F049).....	31
■ Secondary Function (Constants F050-F079).....	33
■ Tertiary Function (Constants F080-F119).....	34
■ Quaternary Function(Constants F120-F179).....	36
■ Initial Settings That Change with The Inverter Capacity	38
CHAPTER 4 PROGRAMMING FEATURES	39
■ Primary Function (Constants F001-F049).....	39
■ Secondary Function (Constants F050-F079).....	57
■ Tertiary Function (Constants F080-F119).....	70
■ Quaternary Function(Constants F120-F179).....	86

CHAPTER 5 MAINTENANCE AND INSPECTION	101
■ Periodical Inspection	101
■ Part Replacement.....	101
CHAPTER 6 FAULT DIAGNOSIS	102
■ Protective and Diagnostic Functions.....	102
Alarm Display and Contents.....	102
Fault Display and Contents.....	106

Standard Specification

Voltage Class		220V class single-phase				220Vclass 3-phase						440V class 3-phase					
Model EI-550-		S1L	S2L	S3L	S5L	01L	02L	03L	05L	07L	10L	01H	02H	03H	05H	07H	10H
Max. Application Motor Output (HP)		1	2	3	5	1	2	3	5	7.5	10	1	2	3	5	7.5	10
Output Features	Rated Output Current (A)	5	8	11	17.5	5	8	11	17.5	25	33	3.4	4.8	5.5	8.6	14.8	18
	Max. Output Voltage (V)	3-phase 200~230V (Proportional to input voltage)				3-phase 200~230V (Proportional to input voltage)						3-phase 380~460V (Proportional to input voltage)					
	Max. Output Frequency (Hz)	400Hz (Programmable)															
Power Supply	Rated Input Voltage and Frequency	Single-phase 200~230V 50/60 Hz				3-phase 200~230V 50/60 Hz						3-phase 380~460V 50/60 Hz					
	Allowable Voltage Fluctuation	-15 ~ +10%															
	Allowable Frequency Fluctuation	±5%															
Control Features	Control Method	Sine wave PWM (V/F control, Vector control selectable)															
	Frequency Control Range	0.1 ~ 400Hz															
	Frequency Accuracy (Temperature Change)	Digital reference : ± 0.01%(-10°C ~ +50°C) Analog reference : ± 0.5% (25°C ±10°C)															
	Frequency Setting Resolution	Digital reference: 0.01Hz (less than 100Hz) · 0.1Hz(100Hz or more) Analog reference: 1/1000 of max. output frequency															
	Output Frequency Resolution	0.01 Hz															
	Overload Capacity	150% rated output current for one minute															
	Frequency Reference Signal	DC0 ~ +10V(20KΩ), 4 ~ 20mA(250Ω), 0 ~ 20mA(250Ω) Pulse train input, frequency setting potentiometer (Selectable)															
	Accel/Decel Time	0.01~6000sec. (4 accel/decel time are independently programmed)															
	Braking Torque	Short-term average deceleration torque 1HP:100% or more · 2HP: 50% or more · 3HP: 20% or more Continuous regenerative torque: Approx. 20%(150% with optional braking resistor, braking transistor built-in)															
V/F Characteristics	Possible to program any V/F pattern																
Protective Features	Motor Overload Protection	Electronic thermal overload relay															
	Instantaneous Overcurrent	Motor coasts to a stop at approx. 250% of inverter rated current															
	Overload	Motor coasts to a stop after 1 minute at 150% of inverter rated output current															
	Overvoltage	Motor coasts to a stop if DC bus voltage exceeds 410V(220VClass) Motor coasts to a stop if DC bus voltage exceeds 820V(440VClass)															
	Undervoltage	Motor coasts to a stop if DC bus voltage is less than 200V(220VClass) Motor coasts to a stop if DC bus voltage is less than 400V(440V Class)															
	Momentary Power Loss	Following items are selectable: Stops if power loss is 15ms or longer Continuous operation if power loss is approx. 0.5s or shorter															
	Cooling Fin Overheat	Protected by electronic circuit															
	Stall prevention level	Can be set individual level during accel/decel, provided/not provided available during coast to a stop															
	Cooling Fan Fault	Protected by electronic circuit (fan lock detection)															
	Ground Fault	Protected by electronic circuit (overcurrent level)															
Power Charge Indication	ON until the DC bus voltage becomes 50V or less																

Other Functions	Multi-function input	Seven of the following input signals are selectable: Forward/reverse run (3-wire sequence), external fault, fault reset , 16-step speed operation , jog command, accel/decel time select, external baseblock, speed search command, accel/decel hold command, LOCAL/REMOTE selection, communication/control circuit terminal selection, emergency stop fault, emergency stop alarm UP/DOWN command, self-test, PID control cancel, PID integral reset/hold.
	Multi-function output	Three of the following output signals (relay contact output, 2 photo-coupler outputs) are selectable: Fault, running, zero speed, at frequency, frequency detection (output frequency \leq or \geq set value), during overtorque detection, during undervoltage detection, minor error, during baseblock, operation mode, inverter run ready, during fault retry, during UV, during speed search, data output through communication, PID feedback loss detection.
	Standard Function	Voltage vector control, RCU-550 digital operator full-range automatic torque boost, slip compensation, DC injection braking current/time at start/stop, frequency reference bias/gain, MODBUS communications (RS-485/422, max. 19.2KBPS), PID control, energy-saving control, constants copy, frequency reference with built-in potentiometer, unit selection for frequency reference setting/display, multi-analog input.
	Digital Operator	Available to monitor frequency reference, output frequency, output current
	Terminals	Main circuit: screw terminals Control circuit: plug-in screw terminal
	Wiring Distance between Inverter and Motor	100M or less
Enclosure	IP20	
Cooling Method	Forced air cooling	
Environmental Conditions	Ambient Temperature	Open chassis -10°C ~ +50°C
	Humidity	90%RH or less (non-condensing)
	Storage Temperature*1	-20°C ~ +60°C
	Location	Indoor (free from corrosive gases or dust)
	Elevation	1000M or less
	Vibration	Up to 9.8m/S ² (1G) at 10 ~ 20Hz Up to 2m/S ² (0.2G) at 20 ~ 50Hz

*1 Storage Temperature during shipping (for short period).

CHAPTER 1 INSTALLATION

■ Inspection

- Inspect the inverter for any damage that may have occurred during shipping.
- Check the nameplate on the EI-550 inverter. Verify the inverter unit is the correct one for the application. The numbering system of the inverter is as shown below.

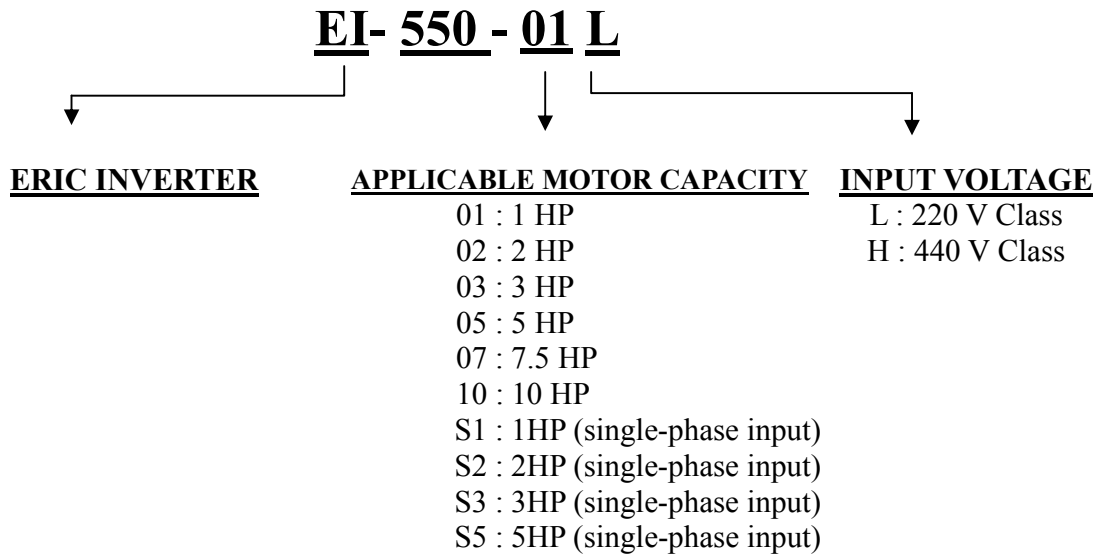

■ Environmental Conditions

- Verify the ambient condition for the mounting location.
 - Ambient temperature should not be below -10°C or exceed 50°C .
 - Relative humidity should be less than 90% (non-condensing).
 - Altitude should be below 3,300ft (1,000m).
- Do not mount the inverter in direct sunlight and isolate it from excessive vibration.

■ Mounting

- The inverter must be mounted vertically with sufficient horizontal and vertical space between adjacent equipment (A= Over 6" (150mm), B= Over 2"(50mm)).

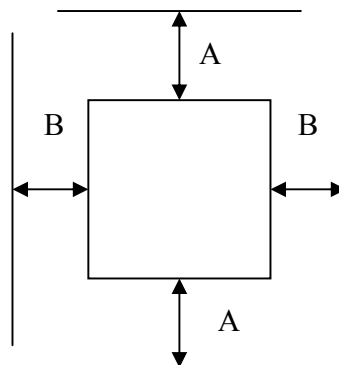

■ Other Precautions

- Do not carry the inverter by the front cover.
- Do not install the inverter in a location where excessive vibration is present. Be cautious when installing on presses or moving equipment.
- The life span of the inverter is greatly affected by the ambient temperature. Install in a location where temperature are within permissible limits (-10 ~ +50°C).
- The inverter operates at high-temperatures - install on a non-combustible surface.
- Do not install the inverter in high-temperature or high-humidity locations.
- Do not install the inverter in a location where oil mist, combustible gas, or dust is present. Install the inverter in a clean location or in an enclosed panel, free of foreign substance.
- When installing the inverter inside a panel with multiple inverters or a ventilation fan, use caution.
If installed incorrectly, the ambient temperature may exceed specified limits.

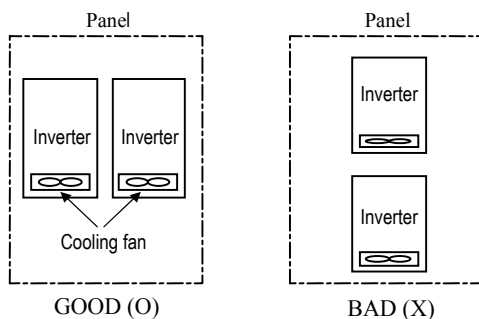

[When installing several inverters in a panel]

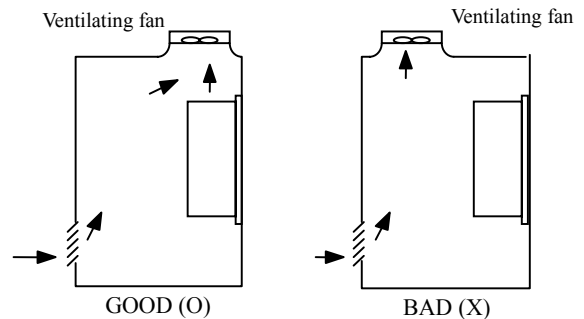

[When installing a ventilating fan in a panel]

- Install the inverter using screws or bolts to insure the inverter is firmly fastened.

■ Dimension

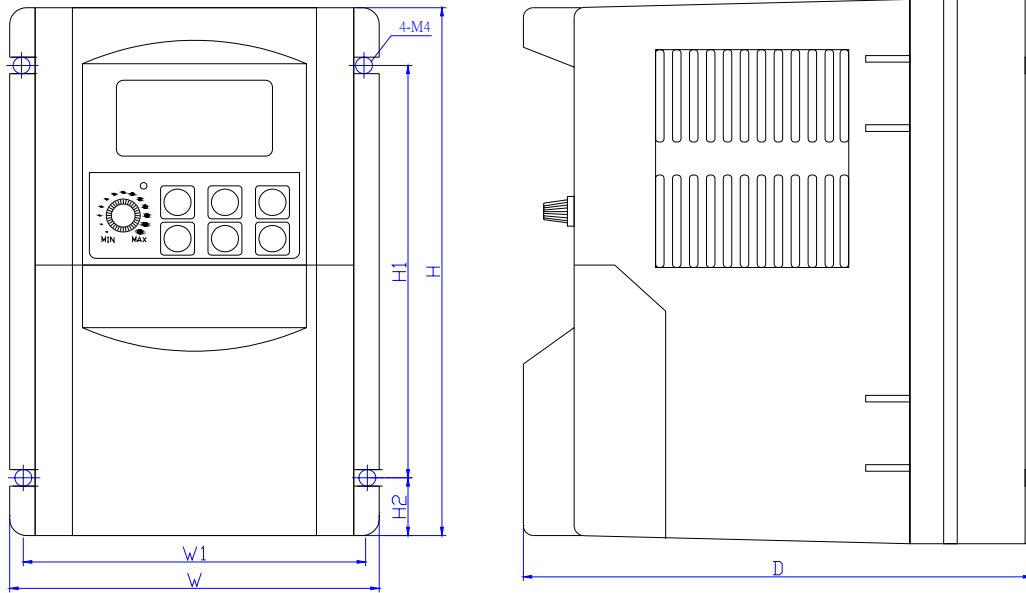

Fig.1

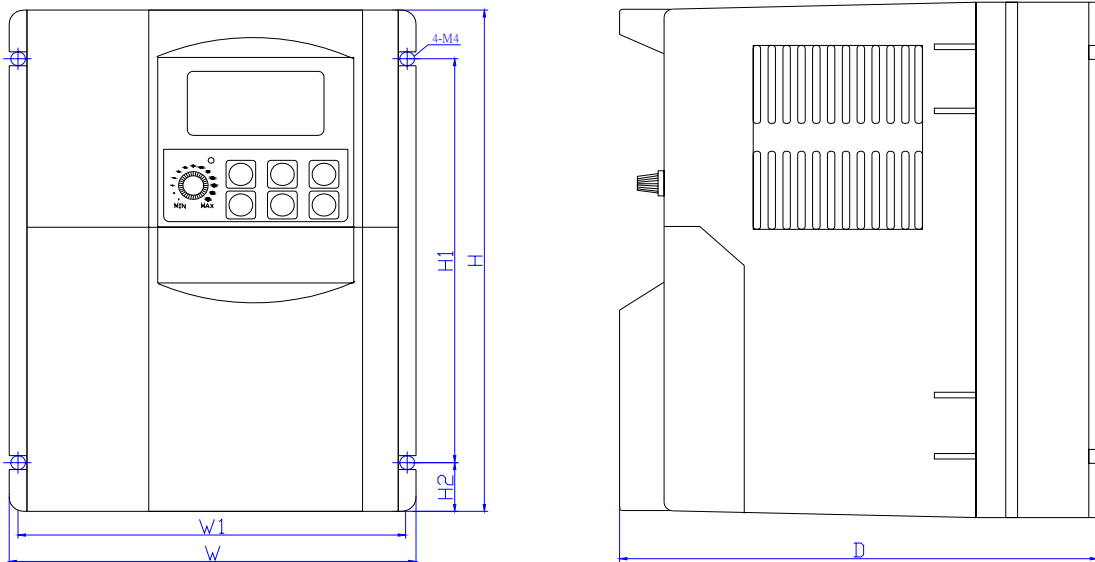

Fig.2

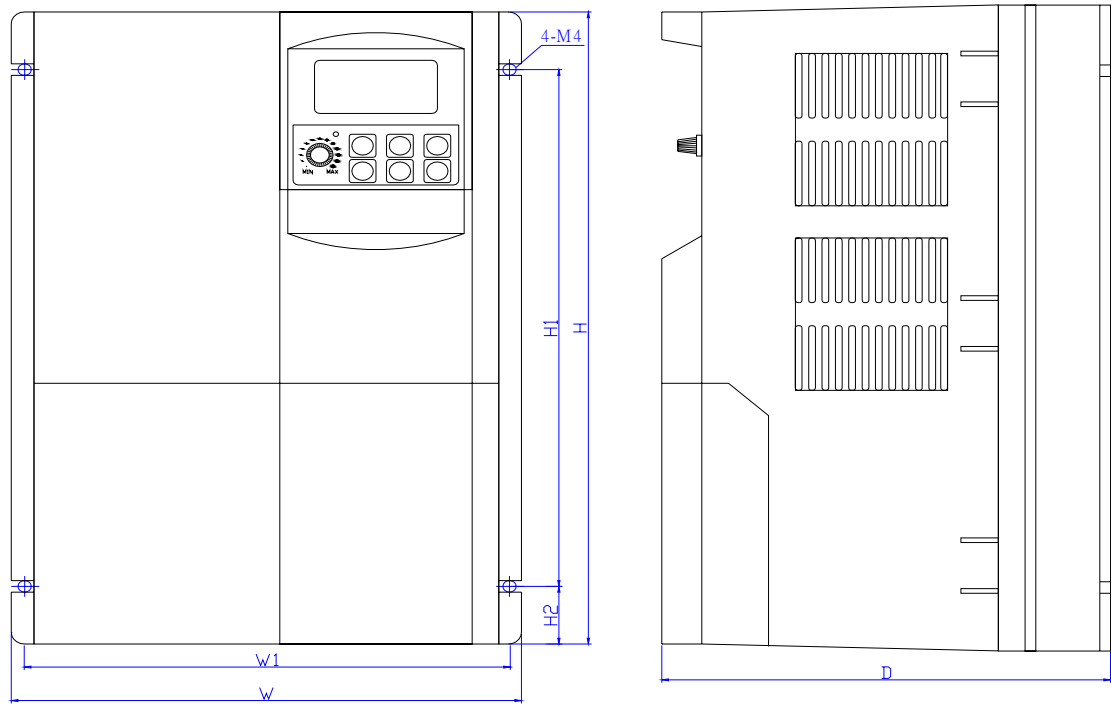

Fig.3

Dimension in mm/Mass in kg

Voltage Class	Capacity (HP)	W	H	D	W1	H1	H2	Mass	Fig.
220V Single-phase	1HP	109	165	150	100	125	20	1.4	1
	2HP		185	161	128	145	20		
	3HP	137	185	161	128	145	20	2.0	2
	5HP								
220V 3-phase	1HP	109	165	150	100	125	20	1.4	1
	2HP		185	161	128	145	20		
	3HP	137	185	161	128	145	20	2.0	2
	5HP								
	7.5HP								
10HP	191	280	168	181	224	28	5.3	3	
440V 3-phase	1HP	109	165	150	100	125	20	1.4	1
	2HP		185	161	128	145	20		
	3HP	137	185	161	128	145	20	2.0	2
	5HP								
	7.5HP								
10HP	191	280	168	181	224	28	5.3	3	

Standard Wiring

Example: 220V/10HP

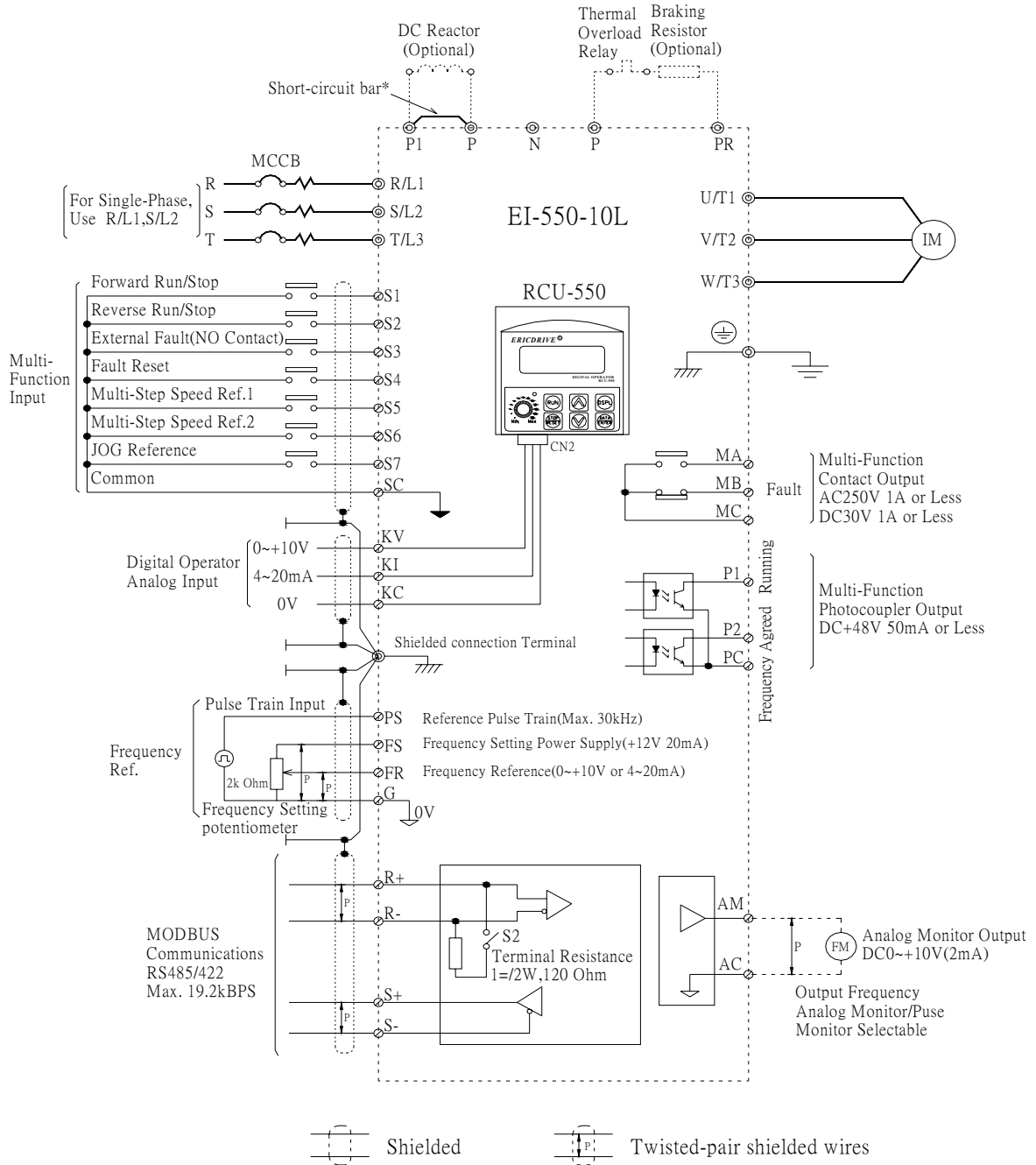

* Short-circuit bar should be removed when connecting a DC reactor

■ Terminal Description

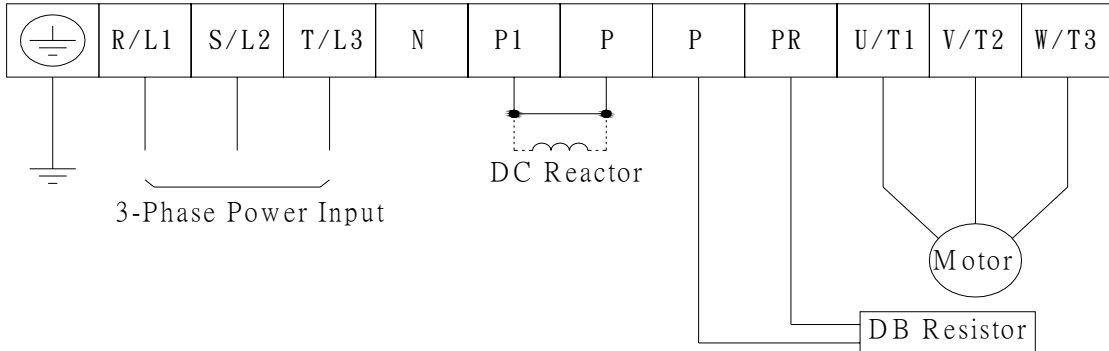

Type	Terminal	Name	Function (Signal Level)
Main Circuit	R/L1 , S/2 , T/L3	AC Power supply input	Use main circuit power input (Use terminals R/L1 and S/L2 for single-phase inverters. Never use terminal T/L3.)
	U/T1 , V/T2 , W/T3	Inverter output	Inverter output to the motor ** Please do not connect to the power supply in case of any damage**
	P , PR	Braking resistor connection	Braking resistor connection
	P1 , P	DC reactor connection	When connecting optional DC reactor, remove the main circuit short-circuit bar
	P , N	DC power supply input	DC power supply input (P: positive , N: negative)
		Grounding	220V Class, type 3 grounding, resistor under 100Ω 440V Class, special type 3 grounding, resistor under 10Ω



WARNING

Normal stray capacitance between the inverter chassis and the power devices inside the inverter and AC line can provide a high impedance shock hazard. Do not apply power to the inverter if the inverter frame is not grounded.

■ Precautions on Wiring

- The internal circuits of the inverter will be damaged if the incoming power is connected and applied to output terminals (U, V, W).
- Use ring terminals with insulated caps when wiring the input power and motor wiring.
- Do not leave wire fragments inside the inverter. Wire fragments can cause faults, breakdowns, and malfunctions.
- For input and output, use wires with sufficient size to ensure voltage drop of less than 2%. Motor torque may drop if operating at low frequencies and a long wire run between inverter and motor.
- When more than one motor is connected to one inverter, total wiring length should be less than 100m. Do not use a 3-wire cable for long distances. Due to increased leakage capacitance between wires, over-current protective feature may operate or equipment connected to the output side may malfunction.
- Please reduce the constants of F080 CARRIER FREQUENCY to prevent the current leakage when the wiring between the inverter and the motor is longer.
- Connect only recommended braking resistor between the P and PR terminals. **Never short P and PR terminals. Shorting terminals may cause internal damage to inverter.**
- The main circuit of the inverter contains high frequency noise, and can hinder communication equipment near the inverter. To reduce noise, install RFI filters or line noise filters on the input side of the inverter.
- Do not use power factor capacitor, surge suppressors, or RFI filters on the output side of the inverter. Doing so may damage these components.
- Always insure the CHARGE LED lamp for the power terminal are OFF before wiring terminals. The charge capacitor may hold high-voltage even after the power is disconnected. Use caution to prevent the possibility of personal injury.

■ Grounding

- The inverter is a high switching device, and leakage current may flow. Ground the inverter to avoid electrical shock. Use caution to prevent the possibility of personal injury.
- Connect only to the dedicated ground terminal on the inverter. Do not use the enclosure or a chassis screw for grounding.
- Grounding wiring should be as thick as possible. Grounding wire should be as short as possible and should be connected to the ground point as near as possible to the inverter.
- The correct grounding is essential when using the inverter. 220V class: less than $100\ \Omega$. 440V class: less than $10\ \Omega$.
- The grounding of the inverter should be separate from the grounding of welder.
- Please refer to the below grounding method when there are multiple inverters used.

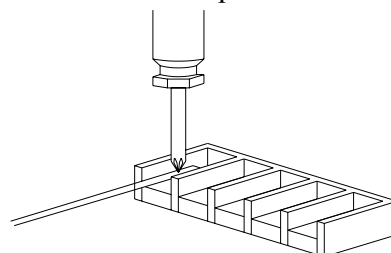
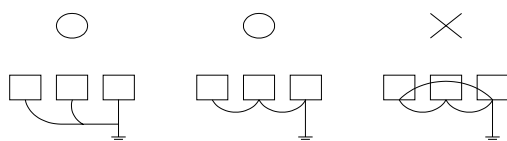

Connect with a Phillips(plus) screw driver.

-
- The specification of electric wires could be referred to the electrician regulation for the safety.







■ Wiring and Terminal Screw Sizes

1. Control Circuit

Model	Terminal symbol	Screw	Tightening torque Nm	Applicable size mm ²	Recommend size mm ²	Type
Common to all models	MA, MB, MC	M3	0.5 0.6	Twisted wire 0.5~1.25 Single wire 0.5~1.25	0.75	Shielded wire
	S1 ~ S7, P1, P2, SC, PC, R+, R-, S+, S-, FS, FR, G, AM, AC, PS, KV, KI, KC	M2	0.22 0.25	Twisted wire 0.5 ~ 0.75 Single wire 0.5 ~ 1.25	0.75	





2. Main Circuit

3-phase 220V Class Input Series

Model	Terminal symbol	Screw	Tightening torque Nm	Applicable size mm ²	Recommend size mm ²	Type
EI-550-01L	R/L1,S/L2,T/L3, P,PR,U/T1,V/T2, W/T3 	M 3.5	0.8 1.0	0.75~2	2	Vinyl-sheathed wire (600V)
EI-550-02L	R/L1,S/L2,T/L3, P,PR,U/T1,V/T2, W/T3 	M 4	1.2 1.5	2~5.5	2	
EI-550-03L	R/L1,S/L2,T/L3, -,+1,+2, P, PR, U/T1,V/T2,W/T3 	M4	1.2 1.5	2~5.5	2	
EI-550-05L	R/L1,S/L2,T/L3, -,+1,+2,P, PR, U/T1,V/T2,W/T3 	M 4	1.2 1.5	2~5.5	2	
EI-550-07L	R/L1,S/L2,T/L3, P1,P,PR,N, U/T1,V/T2,W/T3 	M 5	2.5	5.5~8	8	
EI-550-10L	R/L1,S/L2,T/L3, P1,P,PR,N, U/T1,V/T2,W/T3 	M 5	2.5	5.5~8	8	

*The wire size is set for cooper wires at 75°C or more.

3-phase 440Class Input Series

Model	Terminal symbol	Screw	Tightening torque Nm	Applicable size mm ²	Recommend size mm ²	Type
EI-550-01H EI-550-03H	R/L1,S/L2,T/L3, P, PR,U/T1,V/T2, W/T3 	M 4	1.2 1.5	2~5.5	2	Vinyl-sheathed wire (600V)
EI-550-05H	R/L1,S/L2,T/L3, P, PR,U/T1,V/T2, W/T3 	M 4	1.2 1.5	2~5.5	2	
EI-550-07H	R/L1,S/L2,T/L3, P1,P,PR,N, U/T1,V/T2,W/T3 	M 4	1.4	3.5~5.5	5.5	
EI-550-10H	R/L1,S/L2,T/L3, P1,P,PR,N, U/T1,V/T2,W/T3 	M 5	2.5	5.5~8	5.5	

* The wire size is set for cooper wires at 75°C or more.

Wiring The Main Circuit

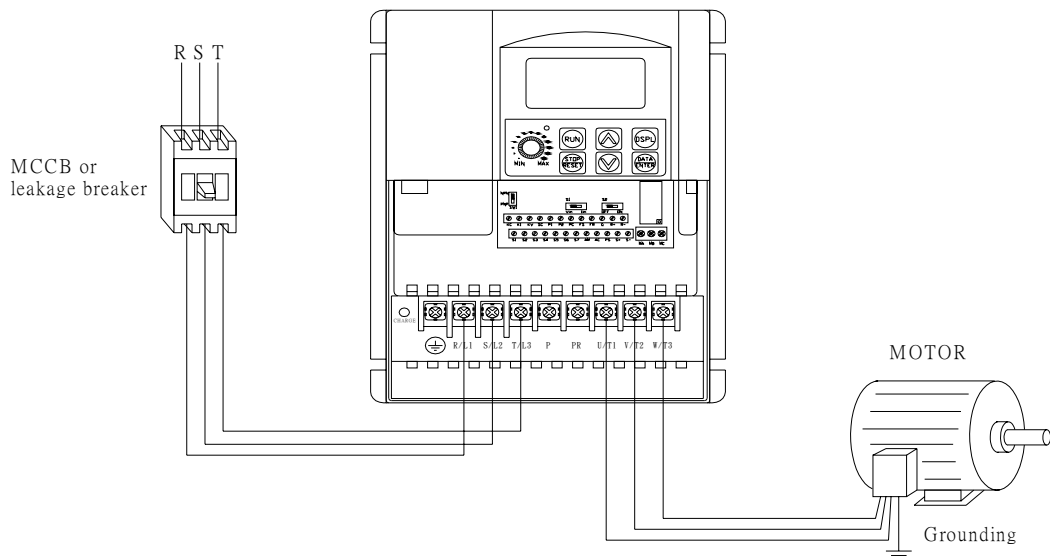

Main Power Supply Input Terminal

Always connect the power supply line to R/L1, S/L2, T/L3. (R/L1, S/L2 for single-phase inverters). Never connect them to terminal U/T1, V/T2, W/T3. Otherwise the inverter may be damaged.

■ Control Terminals

Type	Terminal	Name	Function (Signal Level)			
Main Circuit	Input	Sequence	S1	Multi-function input selection 1	Factory setting closed: FWD run open: REV run	Photo-coupler insulation, 24VDC, 8mA
			S2	Multi-function input selection 2	Factory setting closed: REV run open: FWD run	
			S3	Multi-function input selection 3	Factory setting: External fault (A contact)	
			S4	Multi-function input selection 4	Factory setting: Fault reset	
			S5	Multi-function input selection 5	Factory setting: Multi-step speed reference 1	
			S6	Multi-function input selection 6	Factory setting: Multi-step speed reference 2	
			S7	Multi-function input selection 7	Factory setting: Jog reference	
			SC	Multi-function input selection common	For control signal	
	Frequency reference	PS	Master speed reference pulse train input	33KHz max.		
		FS	Power for frequency setting	+12V(permissible current 20mA max.)		
		FR	Master speed frequency reference	DC 0 ~ +10V(20K Ω , 4 ~ 20mA(250 Ω) 0 ~ 20mA(250 Ω) (1/1000 resolution)		
		G	Frequency reference common	0V		
	Output	Multi-function contact output	MA	A contact output	Factory setting: fault	Contact capacity AC250V1A DC30V1A
			MB	B contact output		
			MC	Contact output common		
		Photo-coupler output	P1	Photo-coupler output 1	Factory setting: Run	Photo-coupler output DC48V , 50mA or less
			P2	Photo-coupler output 2	Factory setting: Frequency agreed	
			PC	Photo-coupler output 1 common	0V	
				AM	Analog monitor output	
	AC	Analog monitor common	0V			
MODBUS Communication	R+	Communications input (+)	MODBUS communication run through RS-485 or RS-422 MODBUS protocol, 19.2KBPS max.			
	R-	Communications input (-)				
	S+	Communications output (+)				
	S-	Communicaitons output (-)				
Digital operator analog input circuit	KV	Analog voltage input	0 ~ +10Vdc (20K Ω)			
	KI	Analog current input	4 ~ 20mA (250 Ω)			
	KC	Analog input common	0V			

Control Circuit Wiring

Please insert the wiring of the control circuit to the wiring hole of the inverter base and adjust the switches according to different control signals.

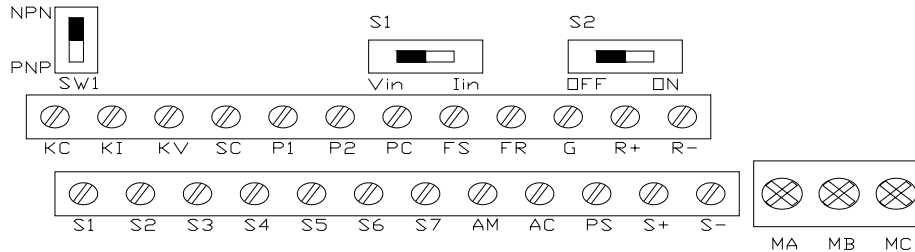

When connecting sequence inputs (S1~S7) with transistor, turn the rotary switch SW1 depending on the polarity (OV common: NPN side, 24V common: PNP side).

Factory setting: NPN side.

Refer to the communication impedance and the analog current input selection and analog voltage input selection for the connection of S2.

Sequence connection with NPN transistor (OV common)

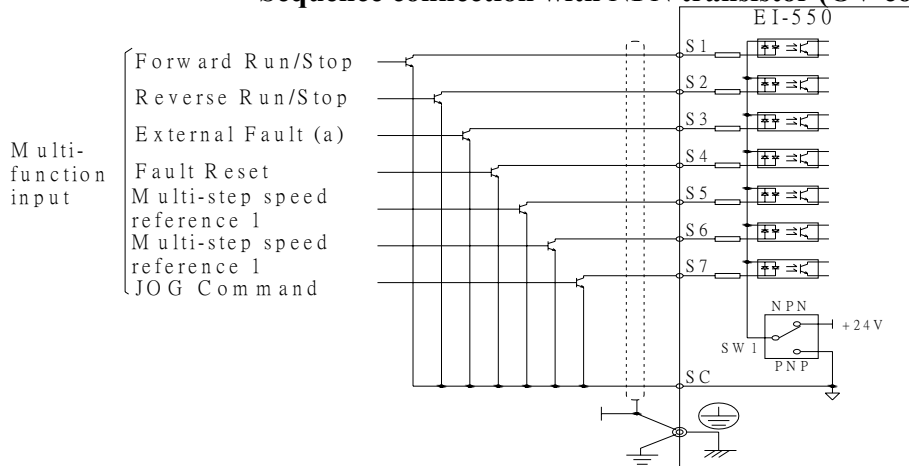

Sequence connection with PNP transistor (24V common)

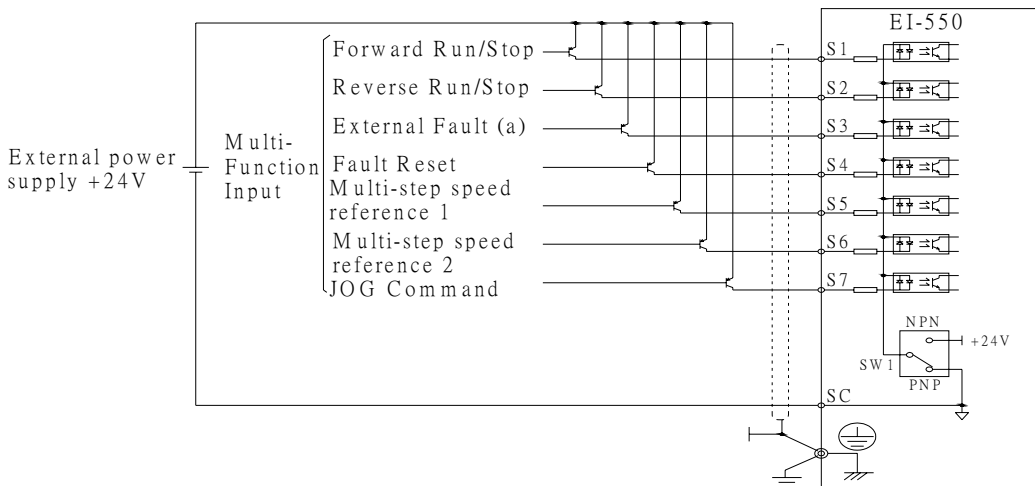

Wiring the control circuit terminals

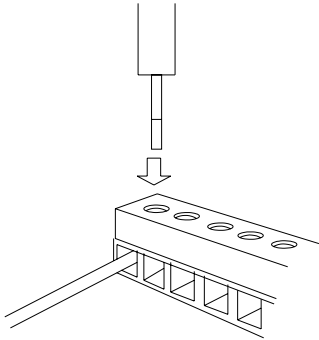

Screwdriver blade width

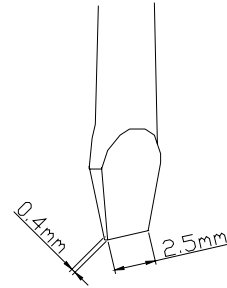

Insert the wire into the lower part of the terminal block and connect it tightly with a screwdriver.



Wire sheath strip length must be 5.5 mm

Wiring Inspection

After completing wiring, check the following:

- Wiring is proper.
- Screws are securely tightened.
- Bare wire in the terminal does not contact other terminals.
- Wire clippings or screws are not left in the unit.

NOTE: If the FWD/REV run command is given during the run command selection (F003=1) from the control circuit terminal, the motor will start automatically after the main circuit input power supply is turned ON.

CHAPTER 2 TEST RUN

■ Test Run

The inverter operates by setting the frequency (speed).

There are three types of operation modes for EI-550 :

1. Run command from the digital operator RCU-550.
2. Run command from the control circuit terminal.
3. Run command from communications (MODBUS communications).

Operation reference or frequency reference constants can be selected separately as shown below.

Name	Constant
Run command F003	=0 . Enables operator RUN, STOP (Initial setting) =1 . Enables control circuit terminal run/stop =2 . Enables communications (MODBUS communications)
Frequency reference selection F004	=0 . Enables operator potentiometer (Initial setting) =1 . Enables frequency reference 1 (Constant F024) =2 . Enables voltage reference 0-10V of control circuit terminal =3 . Enables current reference 4-20mA of control circuit terminal =4 . Enables current reference 0-20mA of control circuit terminal =5 . Enables pulse train reference of control circuit terminal =6 . Enables communications (MODBUS) =7 . Enables voltage reference 0-10V of operator circuit terminal =8 . Enables current reference 4-20mA of operator circuit terminal

Operation steps	Operator (RCU-550)display
1. Switch the frequency potentiometer fully to left and then turn on the power supply.	FREQUENCY REFERENCE = 0.00 Hz
2. Press DSPL to “forward/reverse selection” and then select forward or reverse run by pressing Δ or ∇ key. *** Examine the application. (Never select REV when reverse run is prohibited. *****)	FWD/REV SELECT = FORWARD
3. Press DSPL to “frequency command” and then press RUN key.	FREQUENCY REFERENCE = 0.00 Hz
4. Set the frequency by switching the frequency potentiometer on the digital operator. ***please pay attention to the motor speed which is subject to switching the potentiometer. *****)	FREQUENCY REFERENCE = 38.05 Hz

Operation Check Points

- Motor rotates smoothly.
- Motor rotates in the correct direction.
- Motor does not have abnormal vibration or noise.
- Acceleration or deceleration is smooth.
- Current matching the load flows.
- Digital operator display is correct.

■ Digital Operator (RCU-550) User Instruction

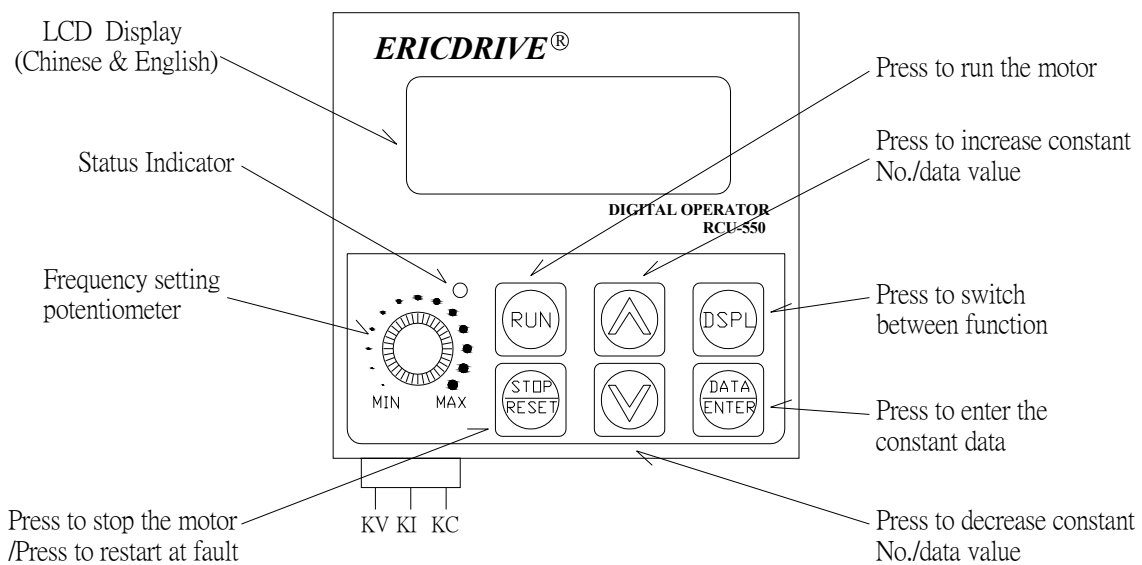

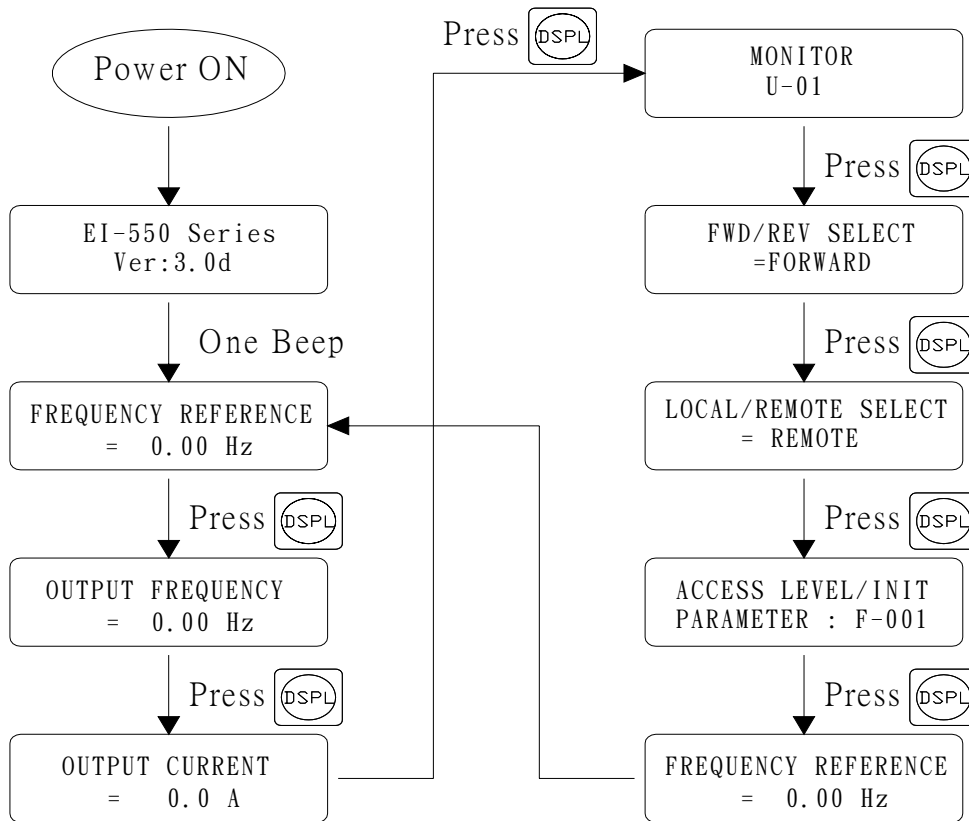

Digital operator analog input terminal is located right behind frequency setting potentiometer; namely, which is the CN2 connector of digital operator and has 3 PIN from left to right following by Analog voltage input (KV), Analog current input (KI) and Analog input common (KC).

■ LCD Display and User Instruction



■ **Multi-function Monitor Items**

Constant No.	Name	Unit	Description
U-01	FREQUENCY REFERENCE	HZ	Frequency reference can be monitored.
U-02	OUTPUT FREQUENCY	HZ	Output frequency can be monitored.
U-03	OUTPUT CURRENT	A	Output current can be monitored
U-04	OUTPUT VOLTAGE	V	Output voltage can be monitored.
U-05	DC VOLTAGE	V	Main circuit DC voltage can be monitored.
U-06	INPUT TERMINAL STATUS	–	Input terminal status of control circuit terminals can be monitored.(S1~7)
U-07	OUTPUT TERMINAL STATUS	–	Output terminal status of control circuit terminals can be monitored.(MA, P1, P2)
U-08	TORQUE MONITOR	%	The amount of output torque can be monitored. When V/F control mode is selected, nothing is displayed.
U-09	FAULT HISTORY	–	Last four fault history is displayed.
U-10	SOFTWARE NO.	–	Software No. can be checked.
U-11	OUTPUT POWER	KW	Output power can be monitored. (-value means regenerative braking. When vector control mode is selected, “----“ is displayed.
U-15	DATA RECEPTION ERROR	–	Contents of MODBUS communication data reception error can be checked. (contents of transmission register No. 003DH are the same)
U-16	PID FEEDBACK	%	PID feedback can be checked (100%/FMAX)
U-17	PID INPUT	%	PID input can be checked. (100%/FMAX)
U-18	PID OUTPUT	%	PID output can be checked. (100%/FMAX)

- U-09 can display last four fault history and monitor the content of those four history by selecting   keys.
- Clear the fault history by setting F001=6 (fault history cleared) or F001=8 or 9.





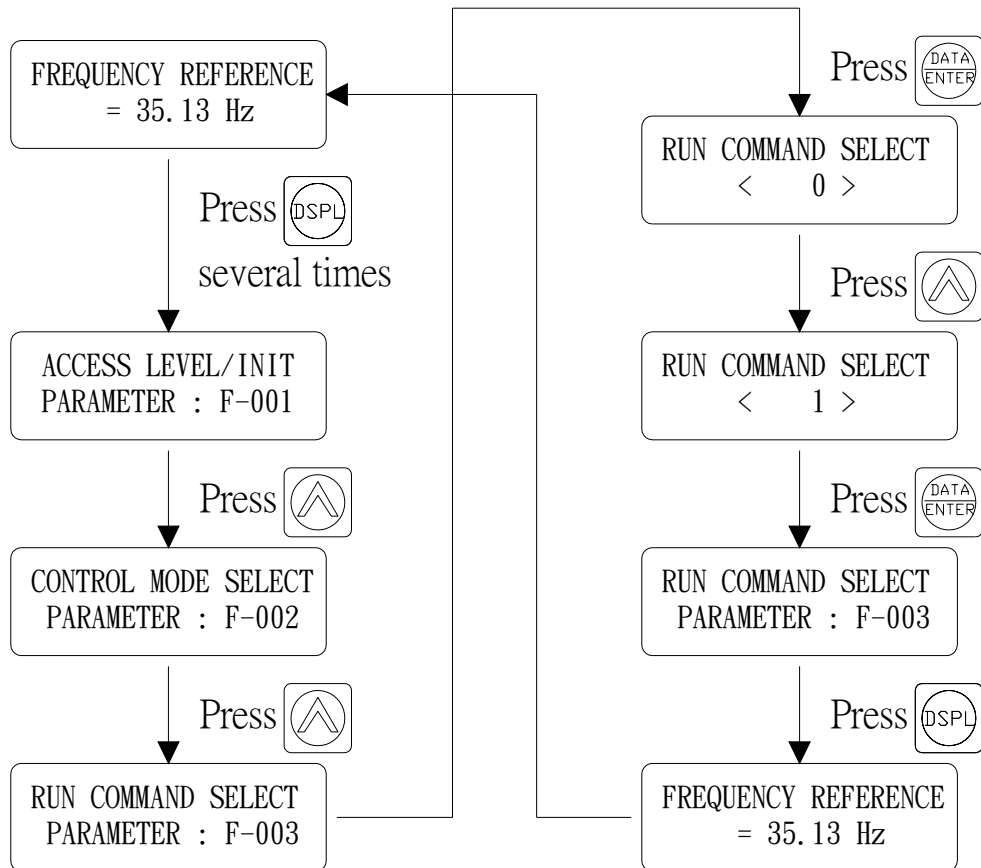



■ **Constants Selection and Setting**

Example: change F003=1 to have multi-function input terminal to control the RUN/STOP command.



■ **Simple Run Setting**

Following is an example of the run setting: Condition request to have frequency 45.00HZ controlled by digital operator; acceleration time is 18 seconds; deceleration time is 3 seconds for forward/reverse setting.

Operation steps	LCD display
1. Turn ON the power supply.	<div style="border: 1px solid black; padding: 5px; width: fit-content; margin: 5px auto;"> FREQUENCY REFERENCE = 0.00 Hz </div>
2. Set constant F004 to 1.	<div style="border: 1px solid black; padding: 5px; width: fit-content; margin: 5px auto;"> FREQUENCY REF SELECT PARAMETER : F-004 </div> Set to 1
3. Set constant F019 to 18.0. (acceleration time) Set constant F020 to 3.0. (deceleration time)	<div style="border: 1px solid black; padding: 5px; width: fit-content; margin: 5px auto;"> ACCELERATION TIME 1 PARAMETER : F-019 </div> Set to 18.0
4. Press  five times. Press   to select forward or reverse.	<div style="border: 1px solid black; padding: 5px; width: fit-content; margin: 5px auto;"> DECELERATION TIME 1 PARAMETER : F-019 </div> Set to 3.0
5. Press  three times. Press   to select frequency 45.00HZ.	<div style="border: 1px solid black; padding: 5px; width: fit-content; margin: 5px auto;"> FWD/REV SELECT = FORWARD </div>
6. Press  one time.	<div style="border: 1px solid black; padding: 5px; width: fit-content; margin: 5px auto;"> FREQUENCY REFERENCE = 45.00 Hz </div>
7. Press  , stop output.	<div style="border: 1px solid black; padding: 5px; width: fit-content; margin: 5px auto;"> OUTPUT FREQUENCY = 45.00 Hz </div>

■ LOCAL/REMOTE Selection

- LOCAL mode: Enables the digital operator for RUN/STOP commands and FWD/REV run commands. Frequency reference can be set by potentiometer or **FREE**.
- REMOTE mode: Enables the digital operator for RUN/STOP commands and FWD/REV run commands or for multi-function input terminal and communications mode.

Select operation method by setting the constant F003:

- F003 : = 0 . . . Enables the digital operator (RCU-550)
= 1 . . . Enables the multi-function input terminal
= 2 . . . Enables communications (MODBUS)

Frequency reference: Setting the constant F004.

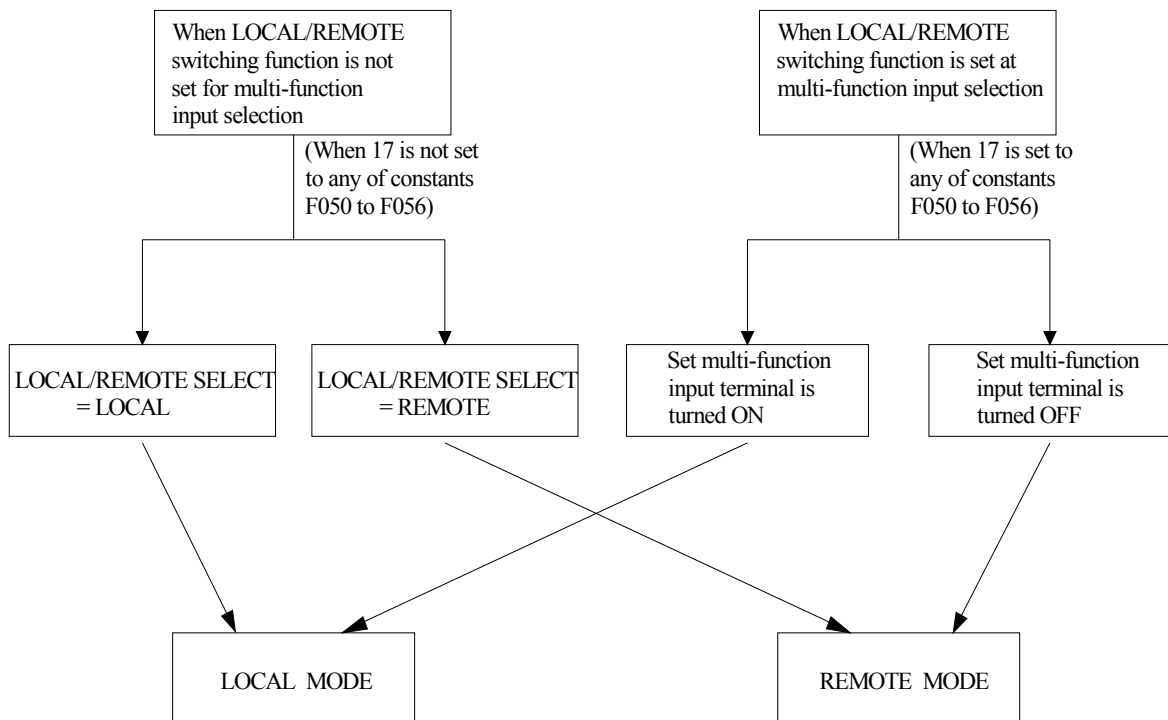

○ Switching LOCAL/REMOTE Modes

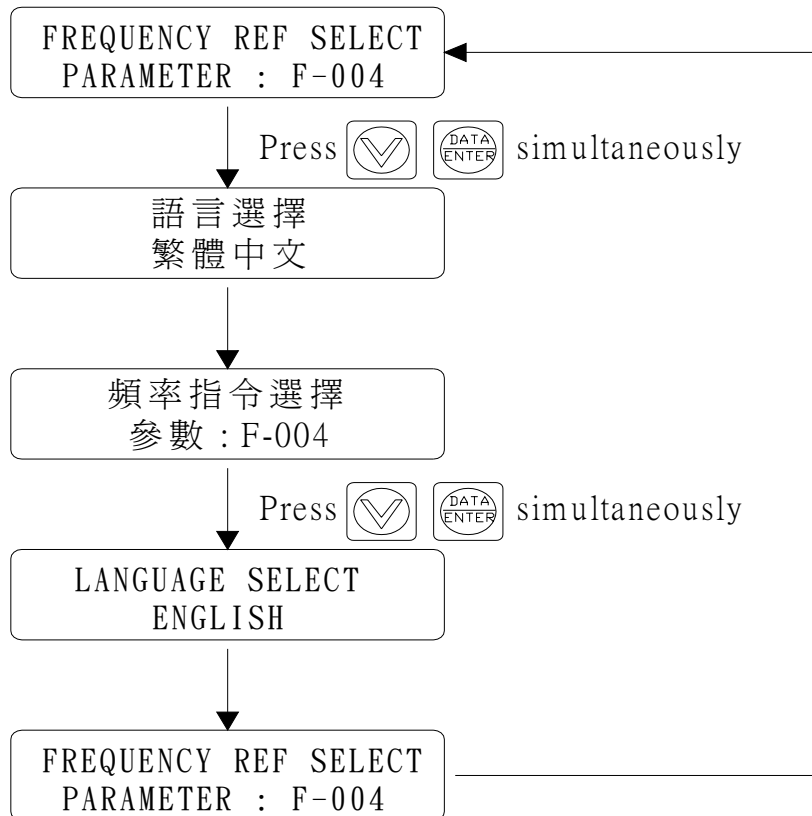

■ **Switching Chinese/English Display**

EI-550 digital operator has Chinese/English display function and the procedure for this function is as below:



※ Press   at the same time in any condition to enable the switch of Chinese/English display.

CHAPTER 3 CONSTANTS LIST

Primary Function (Constants F001 to F049)

No.	Register No. for Transmission	Name	Setting Range	Setting Unit	Initial Setting	Ref. Page
001	301H	ACCESS LEVEL/INIT	0- 4,6,8,9	1	1	39
002	302	CONTROL MODE SELECT	0,1	1*2	0	40
003	303	RUN COMMAND SELECT	0,1,2	1	0	40
004	304	FREQUENCY REF SELECT	0~6	1	0	40
005	305	STOPPING METHOD	0,1	1	0	44
006	306	REVERSE RUN PROHIBIT	0,1	1	0	45
007	307	STOP KEY FUNCTION	0,1	1	0	45
008	308	FREQREF SEL @LOCAL	0,1	1	0	45
009	309	FREQREF SOURCE @OPR	0,1	1	0	45
010	30A	OPERATOR DETECTION	0,1		0	46
011	30B	MAX. FREQUENCY	50.0~400.0Hz	0.1Hz	60.0Hz	46
012	30C	MAX. VOLTAGE	0.1~255.0V	0.1V	200.0V*1	46
013	30D	BASE FREQUENCY	0.2~400.0Hz	0.1Hz	60.0Hz	46
014	30E	MID. FREQUENCY	0.1~399.9	0.1Hz	1.5Hz	46
015	30F	MID. VOLTAGE	0.1~255.0V	0.1V	200.0V*1	46
016	310	MIN. FREQUENCY	0.1~10.0Hz	0.1Hz	1.5Hz	46
017	311	MIN. VOLTAGE	0.1~50.V	0.1V	12.0V*1	46
018	312	ACCEL/DECEL UNIT	0,1	1	0	49
019	313	ACCELERATION TIME 1	0.00~6000S	Depend on F018 setting	10.0s	49
020	314	DECELERATION TIME 1	0.00~6000S	Depend on F018 setting	10.0s	49
021	315	ACCELERATION TIME 2	0.00~6000S	Depend on F018 setting	10.0s	49
022	316	DECELERATION TIME 2	0.00~6000S	Depend on F018 setting	10.0s	49
023	317	S-CURVE SELECTION	0~3	1	0	49
024	318	FREQUENCY REF 1	0.00~400.0Hz	0.01 Hz (less than 100 Hz) 0.1 Hz (100 Hz or more)	6.00Hz	51
025	319	FREQUENCY REF 2	0.00~400.0Hz		0.00Hz	51
026	31A	FREQUENCY REF 3	0.00~400.0Hz		0.00Hz	51
027	31B	FREQUENCY REF 4	0.00~400.0Hz		0.00Hz	51
028	31C	FREQUENCY REF 5	0.00~400.0Hz		0.00Hz	51
029	31D	FREQUENCY REF 6	0.00~400.0Hz		0.00Hz	51
030	31E	FREQUENCY REF 7	0.00~400.0Hz		0.00Hz	51
031	31F	FREQUENCY REF 8	0.00 ~ 400.0Hz		0.00Hz	51

032	320	JOG FREQUENCY	0.00 ~ 400.0Hz		6.00 Hz	52
033	321	FREQREF UPPER LIMIT	0-110%	1%	100%	53
034	322	FREQREF LOWER LIMIT	0-110%	1%	0%	53
035	323	FREQREF UNIT SELECT	0~3999	1	0	53
036	324	MOTOR RATED CURRENT	0-150%	0.1A	*3	54
037	325	E-THERMAL PROTECT	0,1,2	1	0	54
038	326	E-THERMAL PRTECT TIME	1-60min	1 min	8 min	54
039	327	FAN OPERATION	0,1	1	0	57
040	328	MOTOR ROTATION	0,1	—	0	57
041	329	ACCELERATION TIME 3	0.00-6000s	Depend on F018 setting	10.0s	49
042	32A	DECELERATION TIME 3	0.00-6000s	Depend on F018 setting	10.0s	49
043	32B	ACCELERATION TIME 4	0.00-6000s	Depend on F018 setting	10.0s	49
044	32C	DECELERATION TIME 4	0.00-6000s	Depend on F018 setting	10.0s	49

Secondary Function (Constants F050 to F079)

No.	Register No. for Transmission	Name	Setting Range	Setting Unit	Initial Setting	Ref. Page
050	332H	TERMINAL S1 SELECT	1~27	1	1	57
051	333	TERMINAL S2 SELECT	1~27	1	2	57
052	334	TERMINAL S3 SELECT	1~27	1	3	57
053	335	TERMINAL S4 SELECT	1~27	1	5	57
054	336	TERMINAL S5 SELECT	1~27	1	6	57
055	337	TERMINAL S6 SELECT	1~27	1	7	57
056	338	TERMINAL S7 SELECT	1~27,34,35	1	10	57
057	339	TERMINAL MA-MB-MC	0~7,10~18	1	0	62
058	33A	TERMINAL P1 SELECT	0~7,10~18	1	1	62
059	33B	TERMINAL P2 SELECT	0~7,10~18	1	2	62
060	33C	ANALOG FREQREF GAIN	0~255%	1%	100%	64
061	33D	ANALOG FREQREF BIAS	-100~100%	1%	0%	64
062	33E	ANALOGFREQREF FILTER	0.00~2.00S	0.01S	0.10S	64
063	33F	RESERVED				
064	340	FREQ LOSS DETECT	0,1	—	0	65
065	341	MONITOR OUTPUT TYPE	0,1	1	0	66
066	342	MONITOR ITEM SELECT	0~5	1	0	66
067	343	ANALOG MONITOR GAIN	0.00~2.00	0.01	1.00	67
068	344	OPR(V) REF. GAIN	-255~255%	1%	100%	67
069	345	OPR(V) REF. BIAS	-100~100%	1%	0%	67
070	346	OPR(V) REF. FILTER	0.00~2.00S	0.01S	0.10S	67
071	347	OPR(I) REF. GAIN	-255~255%	1%	100%	67
072	348	OPR(I) REF. BIAS	-100~100%	1%	0%	67
073	349	OPR(I) REF. FILTER	0.00~2.00S	0.01S	0.10S	67
074	34A	PULSE TRAIN GAIN	0~255%	1%	100%	68
075	34B	PULSE TRAIN BIAS	-100~100%	1%	0%	68
076	34C	PULSE TRAIN FILTER	0.00~2.00S	0.01S	0.10S	68
077	34D	OPR AI FUNCTION	0~4	1	0	68
078	34E	OPR AI SIGNAL SELECT	0,1	0	0	68
079	34F	OPR AI FREQ BIAS	0~50%	1%	10%	68

Tertiary Function (Constants F080 to F119)

No.	Register No. for Transmission	Name	Setting Range	Setting Unit	Initial Setting	Ref. Page
080	350	CARRIER FREQUENCY	1-4 , 7-9	1	4	70
081	351	PWR LOSS SELECTION	0,1,2	1	0	72
082	352	AUTO RETRY ATTEMPTS	0-10	1	0	73
083	353	JUMP FREQUENCY 1	0.00~400.0Hz	0.01 Hz (less than 100 Hz) 0.1 Hz (100 Hz or more)	0.00Hz	73
084	354	JUMP FREQUENCY 2	0.00~400.0Hz		0.00Hz	73
085	355	JUMP FREQUENCY 3	0.00~400.0Hz		0.00Hz	73
086	356	JUMP BANDWIDTH	0.00~25.50Hz	0.01Hz	0.00Hz	73
087	357	ELAPSED TIME SELECT				
088	358	ELAPSED TIME				
089	359	DCINJBRAKING CURRENT	0~100%	1%	50%	74
090	35A	DCINJ TIME @STOP	0.0~25.5s	0.1s	0.5s	74
091	35B	DCINJ TIME @START	0.0~25.5s	0.1s	0.0s	74
092	35C	STALLP @DECELERATION	0,1	1	0	75
093	35D	STALLP @ACCELERATION	30~200%	1%	170%	75
094	35E	STALLP LEVEL @RUN	30~200%	1%	160%	75
095	35F	FREQUENCY DETECTION	0.00~400Hz	0.01 Hz (less than 100 Hz) 0.1 Hz (100 Hz or more)	0.0Hz	77
096	360	OVERTORQUE DETECT 1	0~4		1	0
097	361	OVER/UNDERTORQUEDET2	0,1	1	0	78
098	362	OVERTORQUE DETLEVEL	30~200%	1%	160%	78
099	363	OVERTORQUE DETTIME	0.1~10.0s	0.1s	0	78
100	364	HOLD OUTFREQ SAVING	0,1	1	0	79
101	365	SPDSRCH DECEL TIME	0.1-10.0s	0.1s	2.0s	79
102	366	SPEED SEARCH LEVEL	0%-200%	1%	150%	79
103	367	TORQUE COMP GAIN	0.0~2.5	0.1	1.0	80
104	368	TORQUE COMP TIME	0.0~25.5s	0.1s	-	80
105	369	T-COMP IRON LOSS	0.0~6550	0.1w (less than 1000w) 1w (1000w or more)	*3	81
106	36A	MOTOR RATED SLIP	0.0~20.0Hz		0.1Hz	*3

107	36B	TERMINAL RESISTANCE	0.0~65.5Ω	0.001Ω (less than 10Ω) 0.01Ω (10Ωor more)	*3	81
108	36C	LEAKAGE INDUCTANCE	0.0~655.0mh	0.01mh(less than 100mh) 0.1mh(100mh or more)	*3	81
109	36D	T-COMP VOLTAGE LIMIT	0~250%	1%	150%	84
110	36E	NO-LOAD CURRENT	0~99%	1%	*3	84
111	36F	SLIP COMP GAIN	0.0~25	0.1	0.0	84
112	370	SLIP COMP TIME	0.0~25.0	0.1s	2.0s	84
113	371	SLIP COMP REGEN	0,1	1	0	84
114	372	RESERVED				
115	373	STALLP AUTO DECREASE	0,1	1	0	85
116	374	STALLP ACCEL/DECEL	0,1	1	0	85
117	375	UNDER TORQUE DETECT	0-4	-	0	85
118	376	UNDER TORQUE LEVEL	0%-200%	1%	10%	85
119	377	UNDER TORQUE TIME	0.1-10.0s	0.1s	0.1s	85

Quaternary Function (Constants F120 to F179)

No.	Register No. for Transmission	Name	Setting Range	Setting Unit	Initial Setting	Ref. Page
120	378H	FREQUENCY REF 9	0.00~400.0Hz	0.01 Hz (less than 100 Hz) 0.1 Hz (100 Hz or more)	0.00Hz	86
121	379	FREQUENCY REF 10	0.00~400.0Hz		0.00Hz	86
122	37A	FREQUENCY REF 11	0.00~400.0Hz		0.00Hz	86
123	37B	FREQUENCY REF 12	0.00~400.0Hz		0.00Hz	86
124	37C	FREQUENCY REF 13	0.00~400.0Hz		0.00Hz	86
125	37D	FREQUENCY REF 14	0.00~400.0Hz		0.00Hz	86
126	37E	FREQUENCY REF 15	0.00~400.0Hz		0.00Hz	86
127	37F	FREQUENCY REF 16	0.00~400.0Hz		0.00Hz	86
128	380	PID CONTROL SELECT	0~8	1	0	87
129	381	PID FEEDBACK GAIN	0.00~10.00Hz	0.01	1.00	88
130	382	PROPORTION GAIN P	0.0~25.0	0.1	1.0	88
131	383	INTEGRAL TIME I	0.0~360.0	0.1s	1.0	88
132	384	DERIVATIVE TIME D	0.00~2.50	0.01s	0.00	88
133	385	PID OFFSET ADJ	-100~100%	1%	0%	88
134	386	INTEGRAL UPPER LIMIT	0~100%	1%	100%	88
135	387	PID DELAY TIME	0.0~10.0	0.1s	0.0	89
136	388	FB LOSS DETECTION	0~2	1	0	89
137	389	FB LOSS DET-LEVEL	0~100%	1%	0%	89
138	38A	FB LOSS DET-TIME	0.0~25.5	0.1s	1.0	89
139	38B	ENERGY SAVE SELECT	0,1	1	0	91
140	38C	ENERGY SAVE K2	0.0~6550	0.1	*5	91
141	38D	ES LOWER LMT@60HZ	0~120%	1%	50%	91
142	38E	ES LOWER LMT@6HZ	0~25%	1%	12%	91
143	38F	POWER AVERAGE TIME	1~200	1=24ms	1(24ms)	92
144	390	SEARCH VOLTAGE LIMIT	0~100%	1%	0%	92
145	391	SEARCH V-STEP @100%	0.1~10.0%	0.1%	0.5%	92
146	392	SEARCH V-STEP @5%	0.1~10.0%	0.1%	0.2%	92
147	393	RESERVED				
148	394	RESERVED				
149	395	PULSE TRAIN SCALING	100~3300	1(1:10Hz)	2500 (25kHz)	93

150	396	PULSE OUT FREQUENCY	0~36	0,1,6,12,24,36	0	93
151	397	MODBUS TIMEOUT DET	0~4	1	0	94
152	398	MODBUS FREQ UNIT	0,1,2,3	1	0	94
153	399	MODBUS SLAVE ADDR	0~31	1	0	94
154	39A	MODBUS BAUD RATE	0~3	1	2	94
155	39B	MODBUS PARITY	0,1,2	1	0	94
156	39C	MODBUS SEND DELAY	10~65ms	1ms	10ms	94
157	39D	RTS CONTROL	0,1	1	0	94
158	39E	ES MOTOR CODE	0~70	1	*5	91
159	39F	ES UPPER LMT@60HZ	0~120%	1%	120%	91
160	3A0	ES UPPER LMT@6HZ	0~25%	1%	16%	91
161	3A1	SEARCHPWR HOLD WIDTH	0~100%	1%	10%	96
162	3A2	POWER DETECT FILTER	0~255	1=4ms	5(20ms)	97
163	3A3	PID OUTPUT GAIN	0.0~25.0	0.1	1.0	97
164	3A4	PID FEEDBACK SELECT	0~5	1	0	97
166	3A6	IN-PHASE LOSS LEVEL	0%-100%	1%	0%	97
167	3A7	IN-PHASE LOSS TIME	0-255s	1s	0s	97
168	3A8	OUT-PHASE LOSS LEVEL	0%-100%	1%	0%	97
169	3A9	OUT-PHASE LOSS TIME	0.0-2.0s	0.1s	0.0s	97
173	3AD	DC INJECTION P GAIN	1-999	1=0.001	83 (0.083)	98
174	3AE	DC INJECTION I TIME	1-250	1=4ms	25 (100ms)	98
175	3AF	CARRIER @LOW SPEED	0,1	01	0	98
176	3B0	CONSTANT COPY SELECT	Rdy, rEd, Cpy, vFy, vA, Sno	-	Rdy	98
177	3B1	CONSTANT READ SELECT	0,1	1	0	98
178	3B2	FAULT HISTORY	Stores, displays most recent 4 alarms		Setting disabled	
179	3B3	SOFTWARE NO.	Displays lower-place 4 digits of software No.		Setting disabled	

No. in refers to those constants which can be changed during operation.

*1 Upper limit of setting range and initial setting are doubled at 440V class.

*2 The settings in modes are different from the initial settings.

*3 Changes depending on inverter capacity. Refer to the below.

*4 When control model selection (F002) is changed, initial setting corresponds to the control mode.

*5 Changes depending on inverter capacity. Refer to Chapter 4 for energy-saving control and motor code.

Initial Settings That Change with The Inverter Capacity

220V Class 3-phase

No.	Name	Unit						
—	INVERTER CAPACITY	HP	1HP	2HP	3HP	5HP	7.5HP	10HP
F036	MOTOR RATED CURRENT	A	3.3	6.2	8.5	14.1	19.6	26.6
F105	T-COMP IRON LOSS	W	6.5	11.1	11.8	19	28.8	43.9
F106	MOTOR RATED SLIP	Hz	2.5	2.6	2.9	3.3	1.5	1.3
F107	TERMINAL RESISTANCE*	Ω	2.575	1.233	0.8	0.385	0.199	0.111
F108	LEAKAGE INDUCTANCE	MH	19.07	13.4	9.81	6.34	4.22	2.65
F110	NO-LOAD CURRENT	%	55	45	35	32	26	30

440V Class 3-phase

No.	Name	Unit						
—	INVERTER CAPACITY	HP	1HP	2HP	3HP	5HP	7.5HP	10HP
F036	MOTOR RATED CURRENT	A	1.6	3.1	4.2	7.0	9.8	13.3
F105	T-COMP IRON LOSS	W	6.1	11.0	11.7	19.3	28.8	43.9
F106	MOTOR RATED SLIP	Hz	2.6	2.5	3.0	3.2	1.5	1.3
F107	TERMINAL RESISTANCE*	Ω	11.22	5.044	3.244	1.514	0.797	0.443
F108	LEAKAGE INDUCTANCE	MH	80.76	53.25	40.03	24.84	16.87	10.59
F110	NO-LOAD CURRENT	%	52	45	35	33	26	30

* Set the value of the motor resistance for one phase.

Initial Setting of V/F Control Mode and Vector Control Mode

No.	Name	V/F control mode (F002 = 0)	Vector control mode (F002 = 1)
F014	MID. FREQUENCY	1.5Hz	3.0Hz
F015	MID. VOLTAGE	12.0V*1*2	11.0V*1
F016	MIN. FREQUENCY	1.5Hz	1.0Hz
F017	MIN. VOLTAGE	12.0V*1*2	4.3V*1
F104	TORQUE COMP TIME	0.3S	0.2S
F111	SLIP COMP GAIN	0.0	1.0
F112	SLIP COMP TIME	2.0S	0.2S

*1 Values are doubled with 440V class.

*2 220V class 7.5HP and 10HP, F107=10.0V. 440V class 7.5HP and 10HP, F107=20.0V.

CHAPTER 4 PROGRAMMING FEATURES

F001: ACCESS LEVEL/INITIATION

Setting	Consant that can be set	Constant that can be referred
0	F001	F002~F179
1	F001~F049	F001~F049
2	F001~F079	F001~F079
3	F001~F119	F001~F119
4	F001~F179	F001~F179
5	Not used	
6	Fault history cleared	
7	Not used	
8	Initialize (2-wire sequence)	
9	Initialize (3-wire sequence) (F052=0)	

NOTE

Err appears on the LCD display for one second and the set data returns to its initial values in the following cases:

- (1) The set values of multi-function input selection 1 to 7 (F050~F056) are the same.
- (2) If the following conditions are not satisfied in the V/F pattern setting:
 - Max. output frequency (F011) \geq Max. voltage output frequency (F013)
 - > Mid. Output frequency (F014)
 - \geq Min. output frequency (F016)
- (3) If the following conditions are not satisfied in the Jump frequency setting:
 - Jump frequency 3 (F085) \leq Jump Frequency 2 (F084)
 - \leq Jump Frequency 1 (F083)
- (4) If Frequency reference lower limit (F034) \leq Frequency reference upper limit (F033)
- (5) If motor rated current (F036) \leq 150% of inverter rated current
- (6) Consant F018 is set to 1 (accel/decel unit is 0.1 sec.) when F018 is set to 0 and the value exceeding 600.0 sec. is set to accel/decel time (F019 to F022, F041 to F042).

F002: CONTROL MODE SELECTION

Control mode selections F002 =0 V/F control mode (initial setting); refer to page 47.
 1 Vector control mode; refer to page 81.

F003: RUN COMMAND SELECTION

Select operation method by setting the constant F003.

- F003=0 . . . Enables the digital operator (initial setting)
- =1 . . . Enables the multi-function input terminal
- =2 . . . Enables communications (MODBUS)

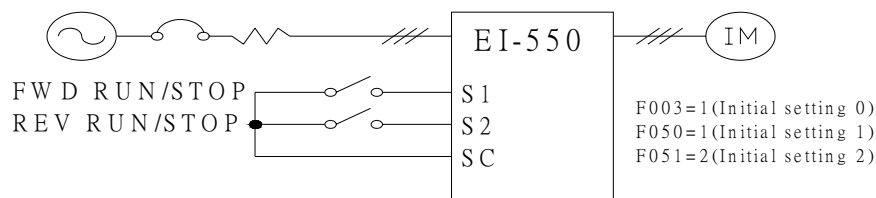

Example for using the multi-function input terminal as operation reference (two-wire sequence).



F004: FREQUENCY REFERENCE SELECTION

Select command method by constant F004.

F004=0: Enables frequency reference setting by potentiometer on digital operator.
 (Initial setting)

- =1: Enables frequency reference setting by   keys on digital operator.
 (Frequency reference 1 F024)
- =2: Voltage reference (0-10V) (FR terminal)
- =3: Current reference (4-20 mA) (FR terminal)
- =4: Current reference (0-20mA) (FR terminal)
- =5: Pulse train reference (PS terminal)
- =6: MODBUS communications(R+, R-, S+, S- terminals)
- =7: Voltage reference in CN2 of digital operator (0-10V)(or KV terminal)
- =8: Current reference in CN2 of digital operator (4-20mA) (or KI terminal)
- =9: Communication card (optional)

F004=2: Example of frequency reference by voltage signal.

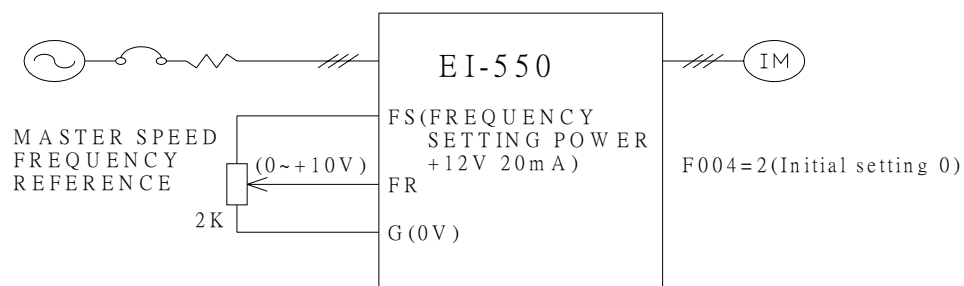

F004=3 (or 4)

When setting frequency by inputting current reference from the control circuit terminal FR, switch the DIP switch S1 to “I_{in}”.

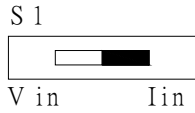

When the DIP switch S1 is switched to “I_{in}” side, never input voltage reference to control circuit terminal FR. The inverter might be damaged.

Select current reference method is as following:

- Current reference 4-20mA . . . constant F004=3
- Current reference 0-20mA . . . constant F004=4

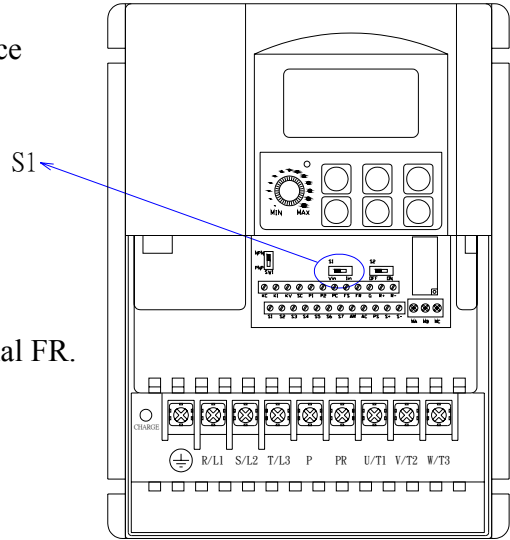

The following two examples are two control method to control frequency reference by external current reference and they are adjusted by S1.

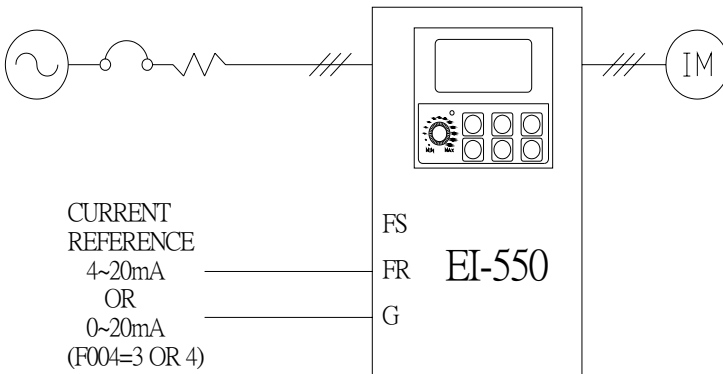

Example 1:

After switching DIP switch S1 to “I_{in}”, set constant F003 to 0, F004=3 (or 4). Press the digital operator keys to run or stop the inverter.

Set frequency by analog current signal constant F004 [0~100% (Max. frequency) /4~20mA or 0~20mA] .

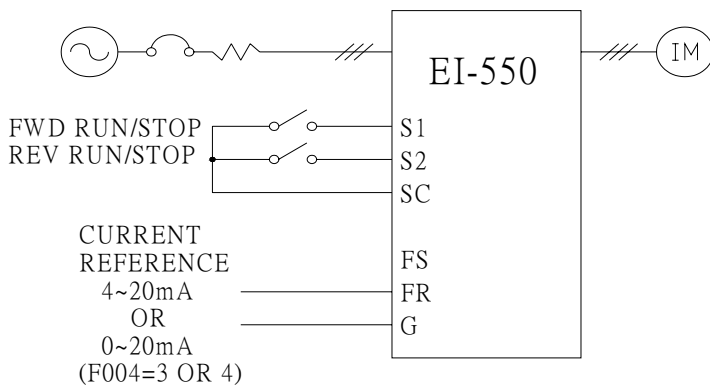

Example 2:

Set constant F003=1, F004=3 (or 4). Multi-function input terminal S1 is set to Forward run/Stop (F050=1). Multi-function input terminal S2 is set to Reverse run/Stop (F051=2).

Set frequency by the analog current signal [0~100% (Max. frequency) /4~20mA or 0~20mA] .

Frequency reference gain (F060)/bias (F061) can be set even when current reference input is selected.

When F004=5, frequency reference can be set by pulse train input from control circuit terminal PS.

Input pulse specification: Voltage type

Low-level voltage	0.8V or less	H duty	30~70%
High-level voltage	3.5V~13.2V	Pulse frequency	0~33kHz

Frequency Reference Method

Frequency reference is a value obtained by multiplying the ratio of the maximum input pulse frequency and actual input pulse frequency by the maximum output frequency.

$$\text{Reference frequency} = \frac{\text{Input pulse frequency}}{\text{Max. pulse train frequency (F149)} \times 10} \times \text{Max. output frequency (F011)}$$

Frequency setting can be set by pulse train input signal [0-100% (Max. Frequency /0-33kHz)] .

No.	Name	Setting value	Initial setting
F003	RUN COMMAND SELECT	1	0
F004	FREQUENCY REFERENCE SELECT	5	0
F149	PULSE TRAIN SCALING	3300 (33kHz)	2500 (25kHz)

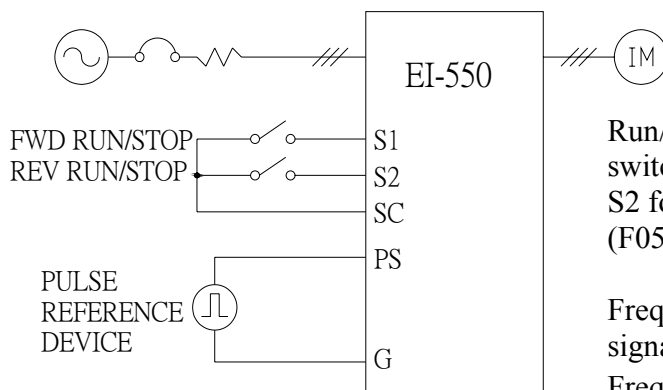

Run/Stop and FWD/REV can be selected by a switch of multi-function terminal input terminal S1, S2 for forward run/stop (F050=1), Reverse run/Stop (F051=2).

Frequency setting can be set by pulse train input signal of control circuit terminal [0-100% (Max. Frequency /0-33kHz)] .

- F004=7 (or 9): Enables frequency reference by digital operator (RCU-550)
- F004=7: Enables frequency reference by PIN1 (0~10V in) (Same as control terminal KV)
- F004=9: Enables frequency reference by PIN2 (4~20mA) (Same as control terminal KI)
- Ground PIN3 (Same as control terminal KC)

EI-550 Operator Analog Speed Reference Block Diagram

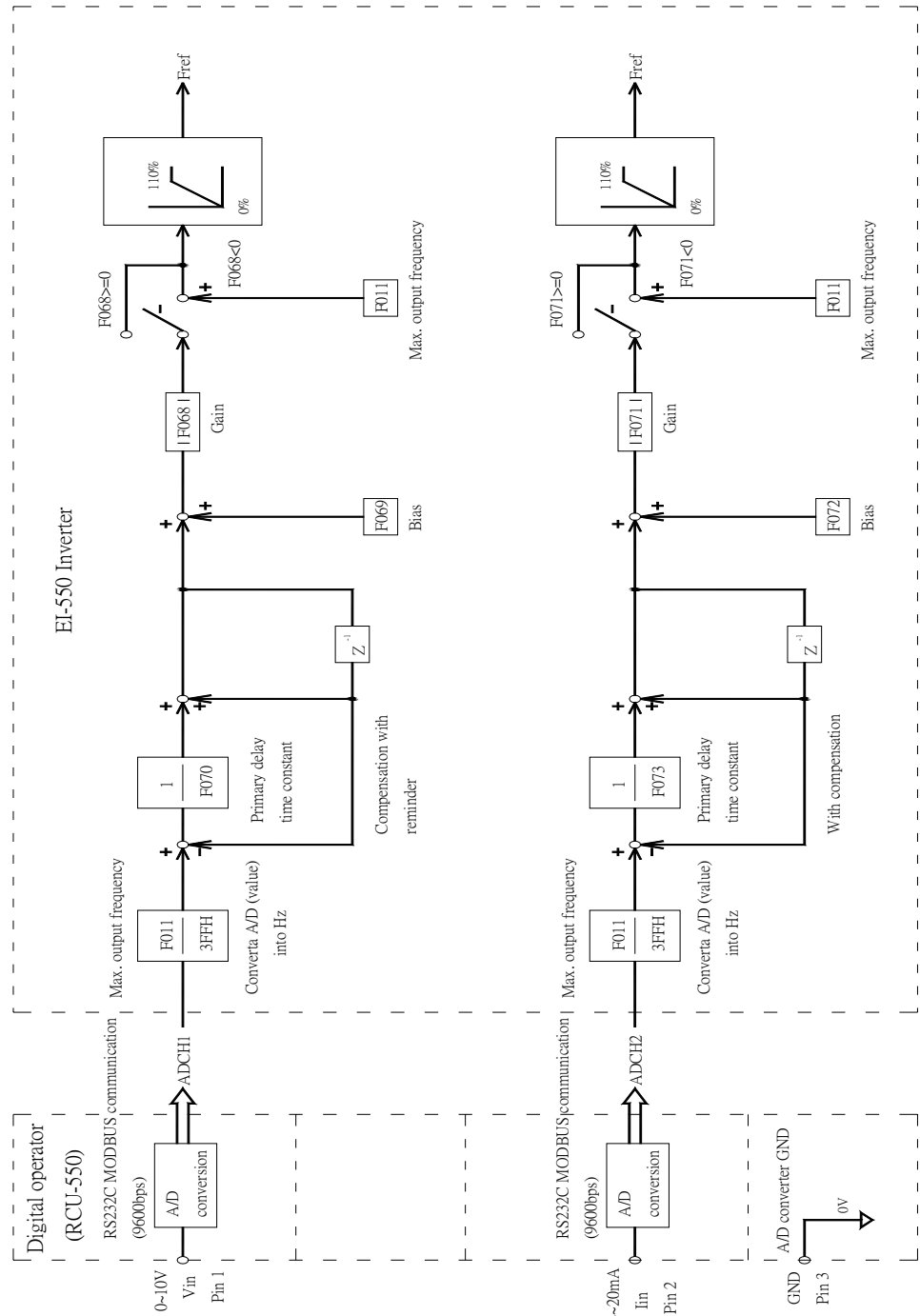

F005: STOPPING METHOD

Select the stopping method suitable for application.

F005 Setting	0 (Initial setting)	1
Stopping Method	Deceleration to stop	Coast to stop

F005=0 Deceleration to Stop

Example when accel/decel time 1 is selected.

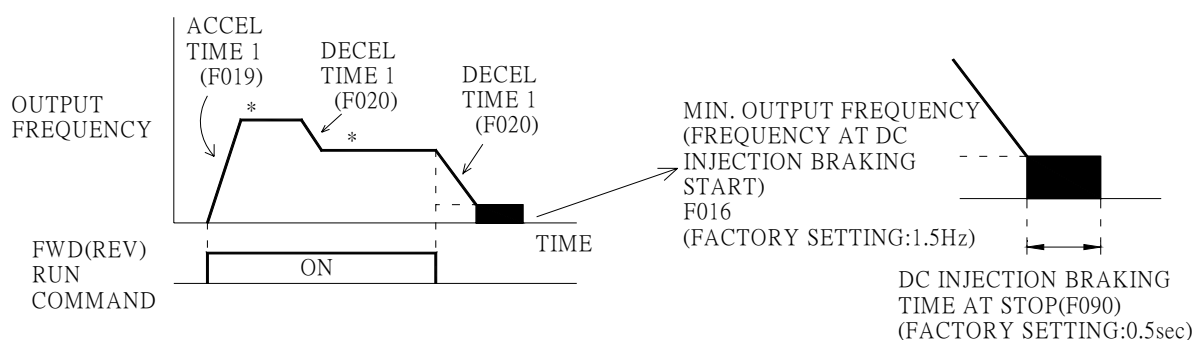

*When frequency reference is changed during running.

Upon termination of the FWD (REV) run command, the motor decelerates at the decel rate determined by the time set to deceleration time 1 and DC injection braking is applied immediately before stop. DC injection braking is also applied when the motor decelerates by setting frequency reference lower than min. output frequency with FWD (REV)run command ON. If the decel time is short or the load inertia is large, overvoltage (OV) fault may occur at deceleration. In this case, increase the decel time or install an optional braking resistor.

Braking torque: Without braking resistor: Approx. 20% torque of motor rating.
With braking resistor: Approx. 150% torque of motor rating.

F005=1 Coast to Stop

Example when accel/decel time 1 is selected.

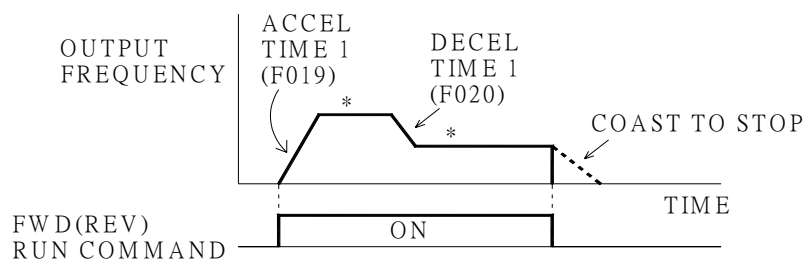

*When frequency reference is changed during running.

Upon removal of the FWD (REV)run command, the motor starts coasting.

F006: REVERSE RUN PROHIBIT

“ Reverse run prohibit” setting does not accept a reverse run command from the control circuit terminal or digital operator. This setting is used for applications where a reverse run command can cause problems.

Setting	0 (Initial setting)	1
Content	Reverse run enabled	Reverse run disabled



F007: STOP KEY FUNCTION

Selects processing when STOP key is pressed during operation either from multi-function input terminal or communications.

Setting	Description
0 (Initial setting)	STOP key effective when running either from multi-function input terminal or communications. When STOP key is pressed, the inverter stops according to setting of constant F005. At this time, the digital operator displays “ STP” alarm (blinking). This stop command is held in the inverter until both forward and reverse run commands are open, or until run command from communications becomes zero.
1	STOP key ineffective when running either from multi-function input terminals or communications.

F008: FREQUENCY REFERENCE SELECTION@LOCAL

F008=0(Initial setting): Enables the setting by potentiometer on digital operator.

=1 : Enables the digital setting by   keys on digital operator. The setting value is stored in constant F024 (FREQUENCY REF 1)

F009: FREQUENCY REFERENCE SOURCE@OPERATOR

When F008 is set to 1, Use   to set the frequency reference.

After setting the frequency reference, press **ENTER** key.

*The initial setting of constant F009 is 0 and when setting the frequency reference, **ENTER** key must be pressed.

F009=0: Enables frequency reference setting by **ENTER** key.

=1: Disables frequency reference setting by **ENTER** key.

F010: OPERATOR DETECTION

F010 is set to 0 when there is no digital operator attached to inverter.

F010=0(Initial setting) : Disable digital operator connection.

=1 : Enable digital operator connection.

(Fault display “oPr” is operator connecting fault.)

F011: MAX. FREQUENCY

F012: MAX. VOLTAGE

F013: BASE FREQUENCY

F014: MID. FREQUENCY

F015: MID. VOLTAGE

F016: MIN. FREQUENCY

F017: MIN. VOLTAGE

No.	Name	Unit	Setting range	Initial setting
F011	MAX. FREQUENCY	0.1 HZ	50.0–400.0HZ	60.0 HZ
F012	MAX. VOLTAGE	1V	0.1–255.0V (0.1–510.0V)	200.0V (400.0V)
F013	BASE FREQUENCY	0.1 HZ	0.2–400.0HZ	60.0HZ
F014	MID. FREQUENCY	0.1 HZ	0.1–399.9HZ	1.5HZ
F015	MID. VOLTAGE	1V	0.1–255.0V (0.1–510.0V)	12.0V (24.0V)
F016	MIN. FREQUENCY	0.1 HZ	0.1–10.0HZ	1.5HZ
F017	MIN. VOLTAGE	1V	0.1– 50.0V (0.1–100.0V)	12.0V (24.0V)

The value in () of F012, F015 and F017 is the setting of 440V class.

- V/F setting is based on output frequency and output voltage. The initial setting is used for general motor and set each pattern when using a special motor (high-speed motor, etc.) or when requiring special torque adjustment of machine.

Be sure to satisfy the following condition.

$$F016 \leq F014 < F013 \leq F011$$

If F016=F014, the set value of F015 is disabled.

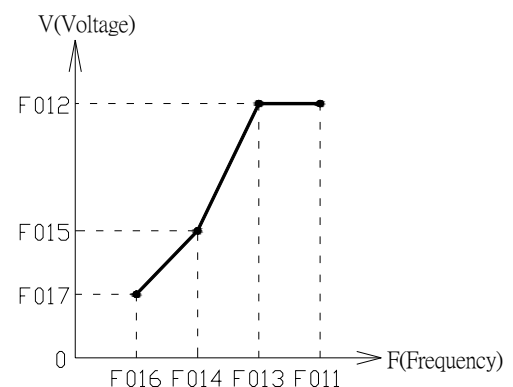

V/F Pattern Application

The initial setting of control mode is V/F pattern. To select the control mode, set F002=0 V/F pattern; F002=1 vector pattern.

- To be able to adjust motor output torque, please change the setting of V/F pattern (F011~F017) and full-range automatic torque boost (F103~F105).

Typical Setting of V/F Pattern

- (1) Set the V/F pattern according to the application as described below.
- (2) For 440V class, the voltage values (F012, F015 and F017) should be doubled.
- (3) When running at a frequency exceeding 50Hz/60Hz, change the maximum output frequency (F011).

(1) For general-purpose applications

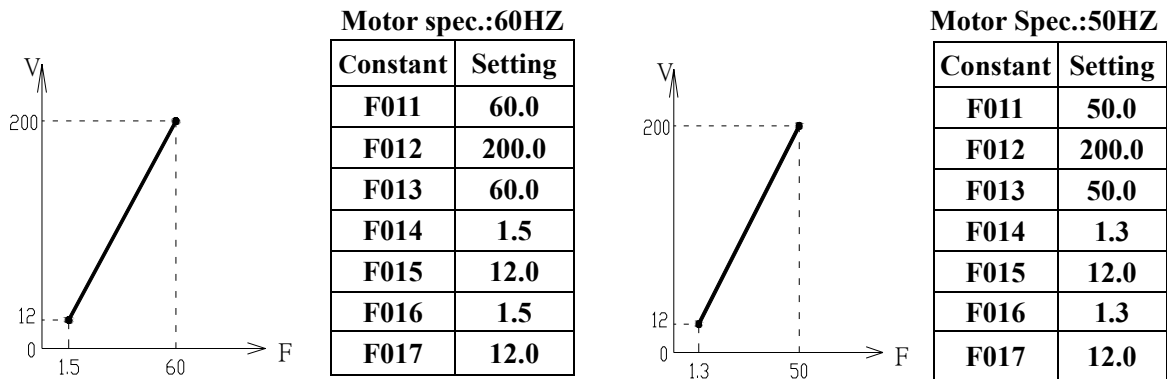

(2) For fans/pumps

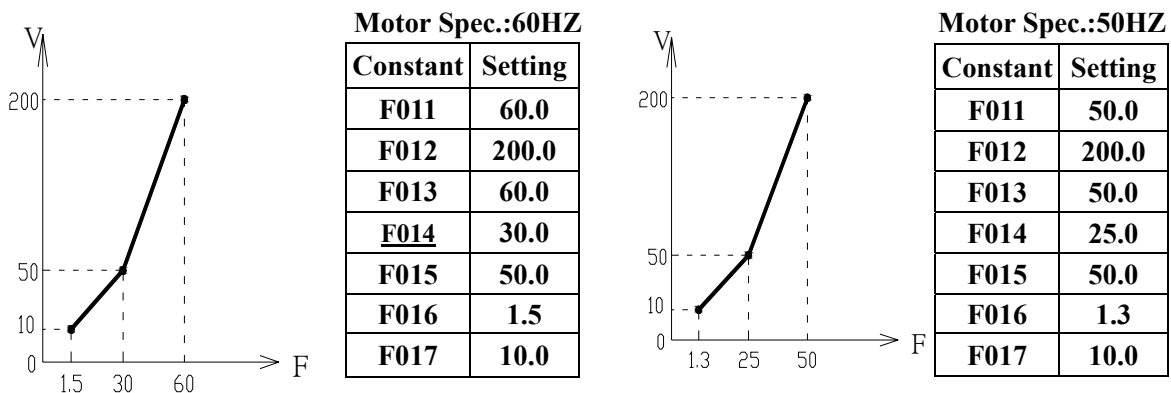

(3) For applications requiring high starting torque

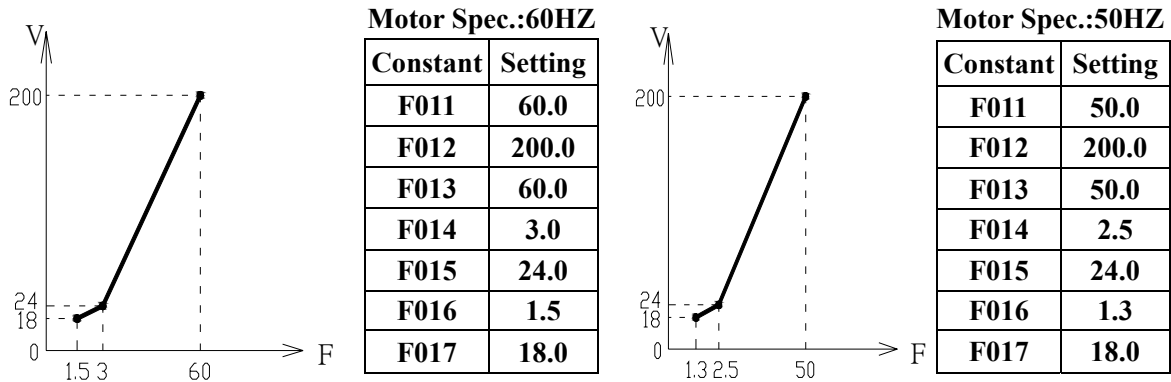

Increasing voltage of V/F pattern increase motor torque, but an excessive increase may cause :

- (1) motor overexcitation to damage inverter.
- (2) motor overheat or vibration so slowly increasing voltage and monitoring on motor current is suggested.

Full-range Automatic Torque Boost (When V/F Mode Is Selected F002=0)

Motor torque requirement changes according to load conditions. Full-range automatic torque boost adjusts voltage of V/F pattern according to the requirement. EI-550 automatically adjusts the voltage during constant-speed operation as well as acceleration. The required torque is calculated by the inverter and this ensures triples operation and energy-saving effects.

$$\boxed{\text{Output voltage}} \propto \boxed{\text{Torque compensation gain (F103)}} \times \boxed{\text{Required torque}}$$

Operation

Normally, no adjustment is necessary for torque compensation gain (F103). When the wiring distance between the inverter and the motor is long, or when the motor generates vibration, change the automatic torque boost gain. In these cases, set the V/F pattern (F011 to F017).

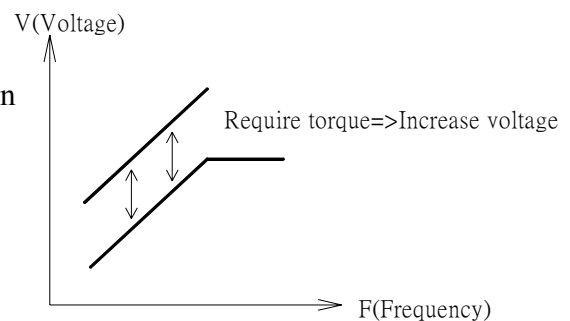

Adjustment of torque compensation time constant (F104) and torque compensation iron loss (F105) are normally not required. However, when the motor generates vibration, increase the setting of F104 and when response is low, reduce the setting of 104.

F018: ACCEL/DECEL UNIT
F019: ACCELERATION TIME 1
F020: DECELERATION TIME 1
F021: ACCELERATION TIME 2
F022: DECELERATION TIME 2
F023: S-CURVE SELECTION
F041: ACCELERATION TIME 3
F042: DECELERATION TIME 3
F043: ACCELERATION TIME 4
F044: DECELERATION TIME 4

No.	Name	Units	Setting range	Initial setting
F019	ACCELERATION TIME 1	Refer to F018 setting	Refer to F018 setting	10.0s
F020	DECELERATION TIME 1			10.0s
F021	ACCELERATION TIME 2			10.0s
F022	DECELERATION TIME 2			10.0s
F041	ACCELERATION TIME 3			10.0s
F042	DECELERATION TIME 3			10.0s
F043	ACCELERATION TIME 4			10.0s
F044	DECELERATION TIME 4			10.0s

F018 Setting	Unit	Setting range
0	0.1s	0.0~999.9s (1000s or less) 1000~6000s(1000s or more)
1	0.01s	0.00~99.99s (100s or less) 100.0~600.0s(100s or more)

Constant F018 can be set during stop.

If the value exceeding 600.0s is set for the accel/decel time when F018=0, "1" cannot be set to F018.

- Accel time: Set the time needed for output frequency to reach 100% from 0%. (100% is the setting value of F011)
- Decel time: Set the time needed for output frequency to reach 0% from 100%.

Using four accel/decel times

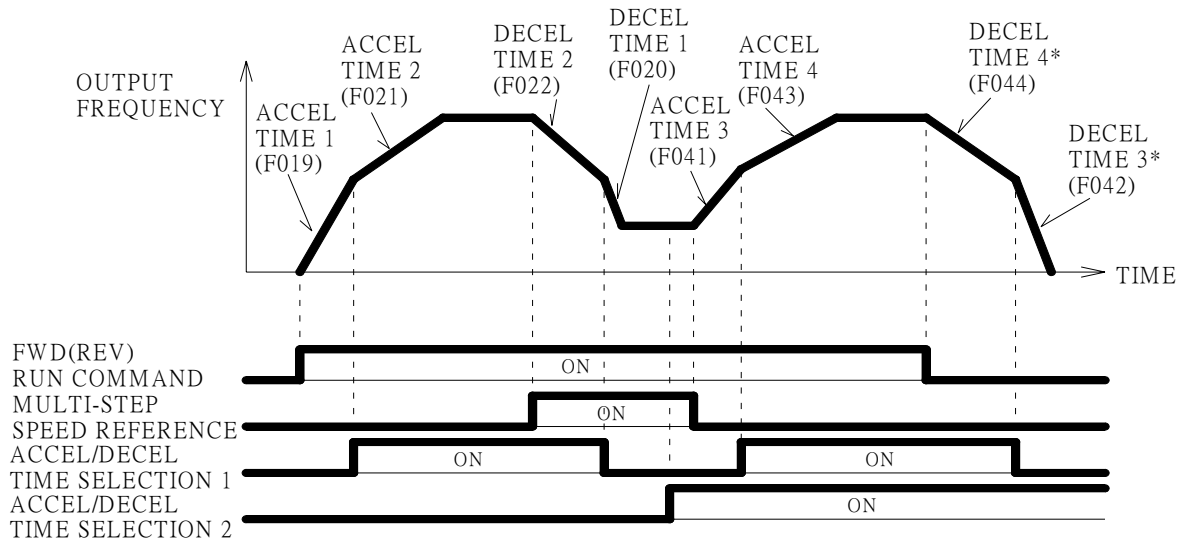

*When "deceleration to a stop" is selected (F005=0)

Accel/Decel time 1	Accel/Decel time 2	Accel time	Decel time
OFF	OFF	Accel time 1 (F019)	Decel time 1 (F020)
ON	OFF	Accel time 2 (F021)	Decel time 2 (F022)
OFF	ON	Accel time 3 (F041)	Decel time 3 (F042)
ON	ON	Accel time 4 (F043)	Decel time 4 (F044)

Set Multi-function input selection (F050~F056) to 11 (accel/decel time switching terminal 1) or to 27 (accel/decel time switching terminal 2).

By the means of the combination of accel/decel time switching terminal 1 and accel/decel time switching terminal 2, accel/decel time is selected by turning ON/OFF the accel/decel time select (terminal S1 to S7).

Soft-start Characteristics F023=0 (Initial Setting)

To prevent shock at machine start/stop, accel/decel can be performed in S-curve pattern.

Setting	S-curve selection
0	S-curve characteristic not provided
1	0.2s
2	0.5s
3	1.0s

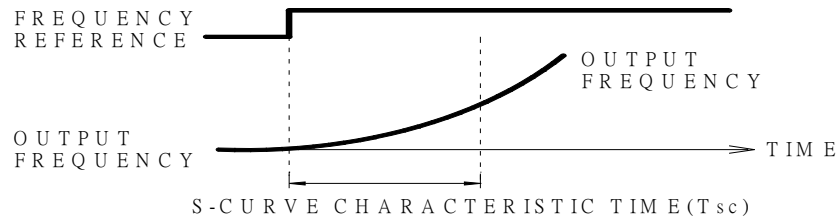

The following time chart shows FWD/REV run switching at deceleration to a stop.

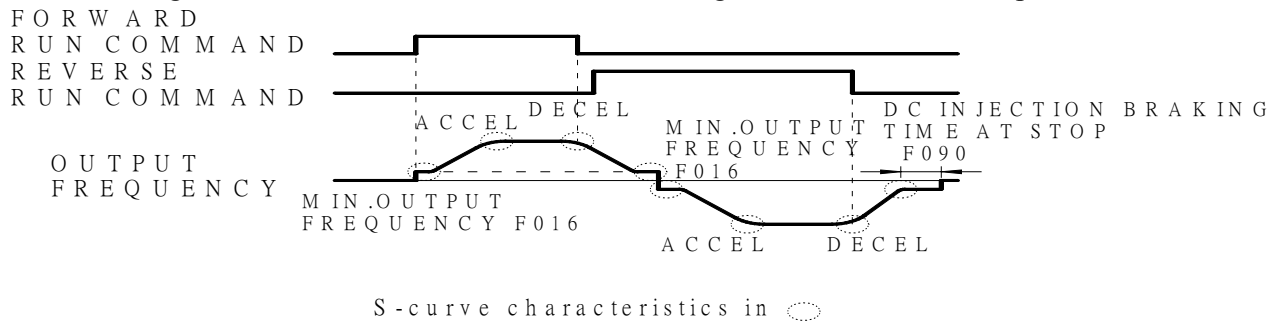

S-curve characteristics in

- F024: FREQUENCY REFERENCE 1 (MAIN FREQUENCY REFERENCE)**
- F025: FREQUENCY REFERENCE 2**
- F026: FREQUENCY REFERENCE 3**
- F027: FREQUENCY REFERENCE 4**
- F028: FREQUENCY REFERENCE 5**
- F029: FREQUENCY REFERENCE 6**
- F030: FREQUENCY REFERENCE 7**
- F031: FREQUENCY REFERENCE 8**

By combining frequency reference and input terminal function selections, up to 16 steps of speed can be set.

8-step speed change

- F003=1 (Operation mode selection)
- F004=1 (Frequency reference selection)
- F024=25.0Hz (Frequency reference 1)
- F025=30.0Hz (Frequency reference 2)
- F026=35.0Hz (Frequency reference 3)
- F027=40.0Hz (Frequency reference 4)
- F028=45.0Hz (Frequency reference 5)
- F029=50.0Hz (Frequency reference 6)
- F030=55.0Hz (Frequency reference 7)
- F031=60.0Hz (Frequency reference 8)

- F054=6 (Multi-function contact input terminal S5)
- F055=7 (Multi-function contact input terminal S6)
- F056=8 (Multi-function contact input terminal S7)
- F053=1

NOTE: When F004 is set to 0, frequency reference 1 (F011) becomes ineffective.

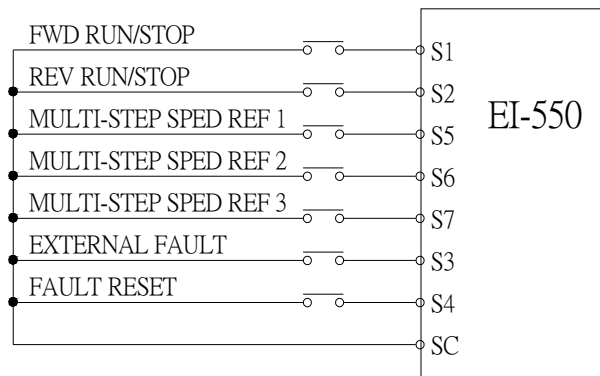

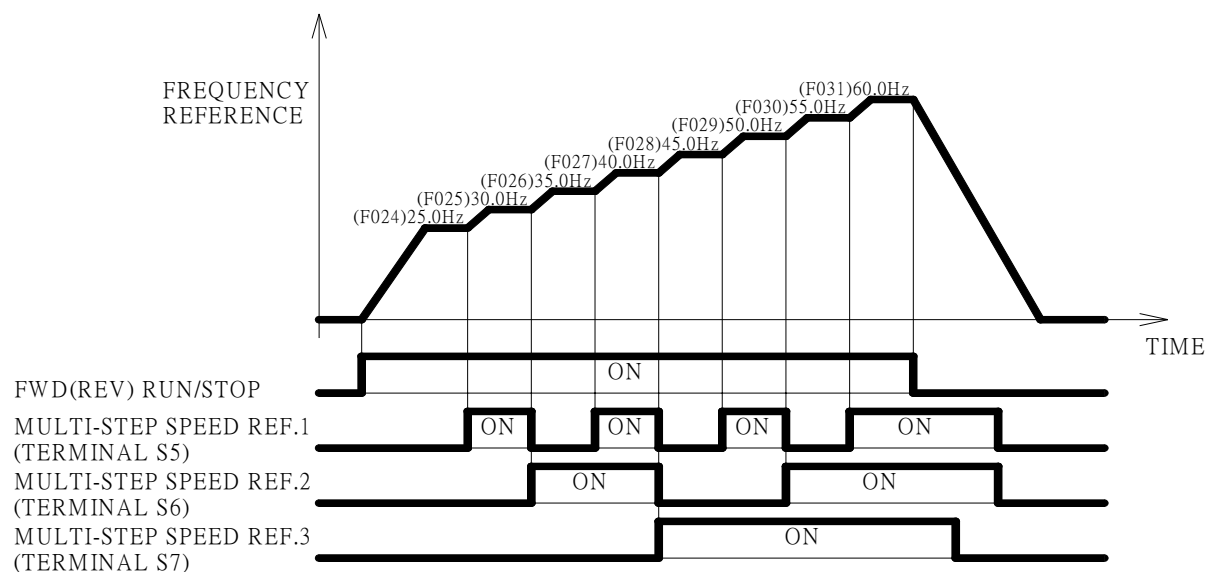

F050=1 (Input terminal S1)
 F051=2 (Input terminal S2)
 F052=3 (Input terminal S3)
 F053=5 (Input terminal S4)

F054=6 (Input terminal S5)
 F055=7 (Input terminal S6)
 F056=8 (Input terminal S7)

16-step speed change

Set frequency reference 9~16 to F120~127. Set input terminal to multi-step speed reference for multi-function input selection 1, 2, 3 and 4.

F032: JOG FREQUENCY

Operating at low speed F032=6.00HZ (Initial setting)

By inputting a jog command and then a forward (reverse) run command, operation is enabled at the jog frequency set in F032. When multi-step speed references 1, 2, 3 or 4 are input simultaneously with the jog command, the jog command has priority.

Constant No.	Name	Setting
F032	JOG FREQUENCY	Initial setting: 6.0HZ
F050 to F056	JOG REFERENCE	Set to "10" for any constant.

F033: FREQUENCY REFERENCE UPPER LIMIT
F034: FREQUENCY REFERENCE LOWER LIMIT

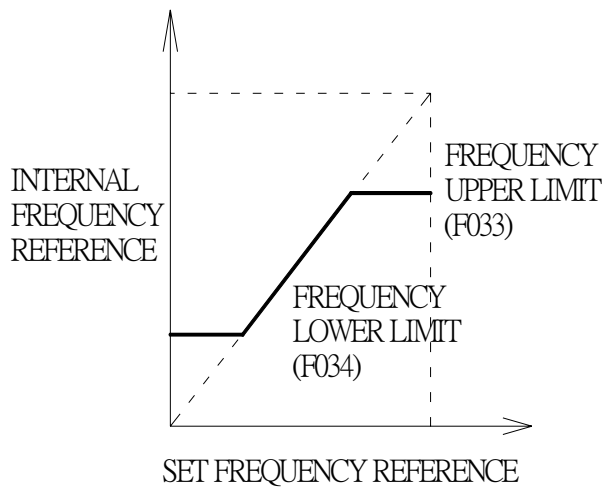

Frequency Reference Upper Limit (F033)
 Sets the upper limit of the frequency reference in units of 1%.
 (F011: Max. output frequency = 100%)

Frequency Reference Lower Limit (F034)
 Sets the lower limit of the frequency reference in units of 1%.
 (F011: Max. output frequency = 100%)

When operating at frequency reference 0, operation is continued at the frequency reference lower limit. However, when frequency reference lower limit is set to less than the minimum output frequency (F016), operation is not performed

F035: FREQUENCY REFERENCE UNIT SELECT

Constants and monitor display for which selection of unit function is valid:

Item	Description	Monitor item	Description
Frequency reference	Frequency reference 1~8 (F024~F031)	Frequency monitor	Frequency reference display (FREF): (U-01)
	Jog frequency (F032)		Output frequency display(FOUT): (U-02)
	Frequency reference 9~16 (F120~F127)		

Unit selection for frequency reference setting/display F035=0 (Initial setting)

Constant	Name	Setting	Description
F035	FREQUENCY REFERENCE UNIT SELECT	0	In units of 0.01Hz (100Hz or less) , 0.1 Hz (100Hz or more)
		1	In units of 0.1%
		2~39	In units of r/min. $r/min=120 \times \text{frequency reference} \div$ motor pole (F035)
		40~3999	By 1 st to 4 th digit of F035, set a 3-digits figure excluding decimal point. Number of 4 th digit Number of 4 th digit. Position of decimal point 0 □□□ 1 □□. □ 2 □. □□ 3 0. □□□ Example: To display 20.0 at 100% of frequency reference, set F035 to “1200”.

The upper limit for each unit is the figure whose fractions below the significant digits are cut off.
(Example) Where the upper limit value for the unit Hz is 60.00 Hz and F035 = 39,
 $120 \times 60.00 \text{ Hz} / 39 = 184.6$, accordingly 184 r/min is displayed for the upper limit
value.

F036: MOTOR RATED CURRENT
F037: E-THERMAL PROTECT
F038: E-THERMAL PROTECT TIME

■ **Motor Protection**

○ **Motor Overload Detection**

EI-550 protects against motor overload with a built-in electronic thermal overload relay.
Please do the proper setting as following.

Motor rated current(F036): Set to the rated current value shown on the motor nameplate.

Note: Setting to 0.0A disables the motor overload protective function.

Motor Overload Protection Selection (F037, F038)

F037 Setting	Electronic thermal characteristics
0 (Initial setting)	Applied to general-purpose motor
1	Applied to inverter motor
2	Electronic thermal overload protection not provided

Constants No.	Name	Unit	Setting range	Initial setting
F038	E-THERMAL PROTECT TIME	1 min	1~60 min	8 min

The electronic thermal overload function monitors motor temperature, based on inverter output current and time, to protect the motor from overheating. When electronic thermal overload relay is enabled, an “**OL1**” error occurs, shutting OFF the inverter output and preventing excessive overheating in the motor. When operating with one inverter connected to one motor, an external thermal relay is not needed. When operating several motors with one inverter, install a thermal relay on each motor.

General-purpose Motor and Inverter Motor

Induction motors are classified as general-purpose motors or inverter motors, based on their cooling capabilities. Therefore, the motor overload function operates differently between these two motor types.

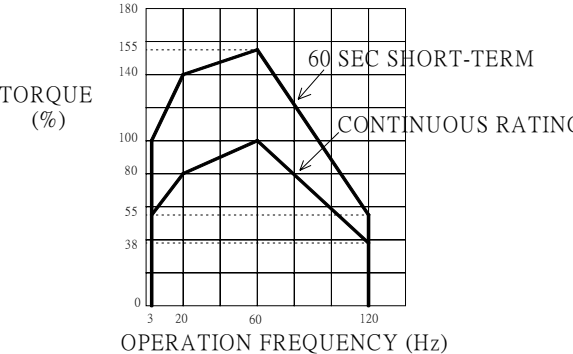
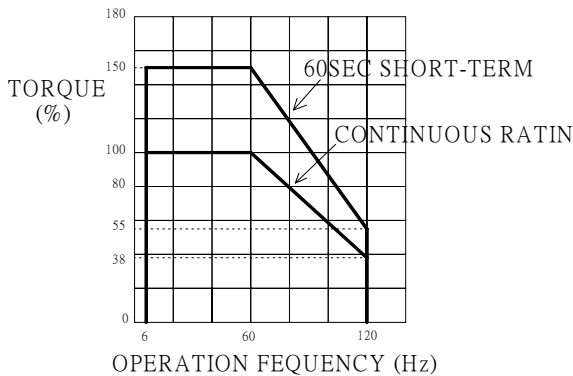
	Cooling effect	Torque characteristics	Electronic thermal overload
General-purpose Motor	Effective when operated at 50/60Hz from commercial power supply.	 <p>Base Frequency $\left[\frac{V/F \text{ for } 60\text{Hz}}{\text{Input Voltage } 220\text{V}} \right]$ 60Hz</p> <p>For-low-speed operation, torque must be limited in order to stop motor temperature rise</p>	“OL1” error (motor overload protection) occurs when continuously operated at 50/60Hz or less at 100% load.
Inverter Motor	Effective even when operated at low speed (approx. 6Hz).	 <p>Base Frequency $\left[\frac{V/F \text{ for } 60\text{Hz}}{\text{Input Voltage } 220\text{V}} \right]$ 60Hz</p> <p>Use an inverter motor for continuous operation at low speed.</p>	Electronic thermal overload protection not activated even when continuously operated at 50/60Hz or less at 100% load.

F039: FAN OPERATION

In order to increase lifetime, the cooling fan can be set to operate only when inverter is running.
F039= 0 (Initial setting) : Operates only when inverter is running (Continues operation for 1 minute after inverter is stopped.)
= 1 : Operates with power ON.

F040: MOTOR ROTATION

It is possible to select the direction in which the motor rotates when the FORWARD RUN command is executed. The motor rotates in the opposite direction when the REVERSE RUN command is executed.

F040 Setting	Description
0	The motor rotates in the counterclockwise direction as viewed from the load when the FORWARD RUN command is executed.
1	The motor rotates in the clockwise direction as viewed from the load when the FORWARD RUN command is executed.

Operation Check Points

- Motor rotates smoothly.
- Motor rotates in the correct direction.
- Motor does not have abnormal vibration or noise.
- Acceleration and deceleration are smooth.
- Current matching the load flows.
- Status Indicators and Digital Operator Display are correct.

F041: ACCELERATION TIME 3**F042: DECELERATION TIME 3****F043: ACCELERATION TIME 4****F044: DECELERATION TIME 4**

Please refer F041, F042, F043 and F044 to page 49.

F050: TERMINAL S1 SELECTION**F051: TERMINAL S2 SELECTION****F052: TERMINAL S3 SELECTION****F053: TERMINAL S4 SELECTION****F054: TERMINAL S5 SELECTION****F055: TERMINAL S6 SELECTION****F056: TERMINAL S7 SELECTION**

- Multi-function input terminal S1 to S7 functions can be changed when necessary by setting constants F050 to F056 respectively. The same value cannot be set to different constant settings.

- The setting value and reference is as below.

Setting	Name	Description	Ref.
0	FWD/REV run command	Setting enabled only for F052 (terminal S3)	59
1	FWD run (2-wire sequence selection)		40
2	REV run (2-wire sequence selection)		40
3	External fault (a contact input)	Inverter stops by external fault signal input. Digital operator display is “EF□”.	—
4	External fault (b contact input)		—
5	Fault reset	Resets the fault. Fault reset not effective with the run signal ON.	51
6	Multi-step speed reference 1		51
7	Multi-step speed reference 2		51
8	Multi-step speed reference 3		51
9	Multi-step speed reference 4		51
10	JOG command		52
11	Accel/decel time select 1		50
12	External base block (a contact input)	Motor coast to a stop by this signal input.	—
13	External base block (b contact input)	Digital operator display is bb (blinking)	—
14	Search command from maximum frequency	Speed search command signal	59
15	Search command from set frequency		59
16	Accel/decel hold command		60
17	LOCAL/REMOTE selection		60
18	Communication/ control circuit terminal selection		61
19	Emergency stop fault (a contact input)	Inverter stops by emergency stop signal input according to stopping method selection(F005). When frequency coasting to a stop (F005 is set to 1) method is selected, inverter coasts to a stop according to decel time setting 2 (F022).	—
20	Emergency stop alarm (a contact input)		—
21	Emergency stop fault (b contact input)		—
22	Emergency stop alarm (b contact input)	Digital operator display is “STP” (lit at fault, blinking at alarm)	—
23	PID control cancel		90
24	PID integral reset		90
25	PID integral hold		90
26	Inverter overheat alarm (OH3)	Digital operator displays OH3 (blinking) when the inverter has overheat signal.	—
27	Accel/decel time select 2		50
34	UP/DOWN command	Setting enabled only for F056 (terminal S7)	61
35	Self-test	Setting enabled only for F056 (terminal S7)	62

- Initial setting:

Constant No.	Terminal	Initial setting
F050	S1	1
F051	S2	2
F052	S3	3
F053	S4	5
F054	S5	6
F055	S6	7
F056	S7	10

- **Terminal Function at 3-wire Sequence Selection (F052=0)**

When 0 is set at the terminal S3 (F052),
terminal S1, S2 and S3 become the following command.

S1: Run command
S2: Stop command
S3: FWD/REV run command

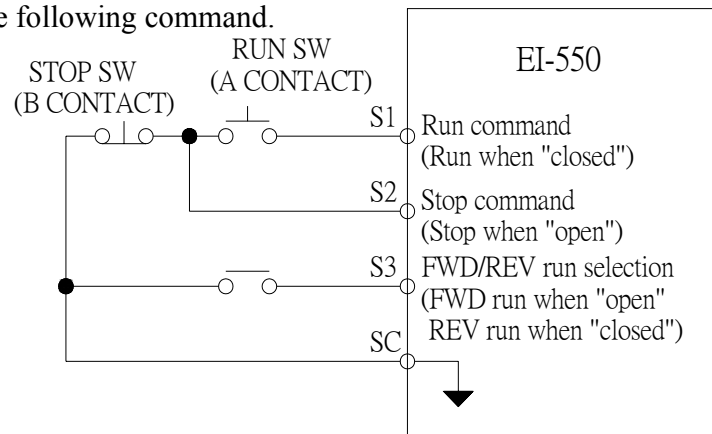

- **Restarts A Coasting Motor without Stopping Speed Search Command (F052=14 or 15)**

After inputting restarting speed search command in a coasting motor, inverter will stop output for a while (Min. Base Block time), then it will start to execute speed search.

Set multi-function input terminal (F050~F056) to
14 (search command from “maximum output frequency”)
15 (search command from “set frequency”)

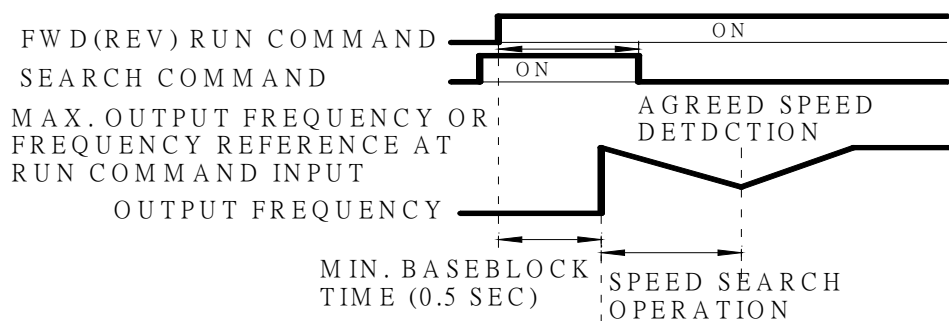

○ **Holding Accel/Decel Temporarily (F052=16)**

To hold acceleration or deceleration, input accel/decel hold command. The output frequency is maintained when the accel/decel hold command is input during acceleration or deceleration.

When the stop command is input during accel/decel prohibition command input, accel/decel hold is released and operation ramps to stop.

Set multi-function input selection (F050 to F056) to 16 (accel/decel prohibit).

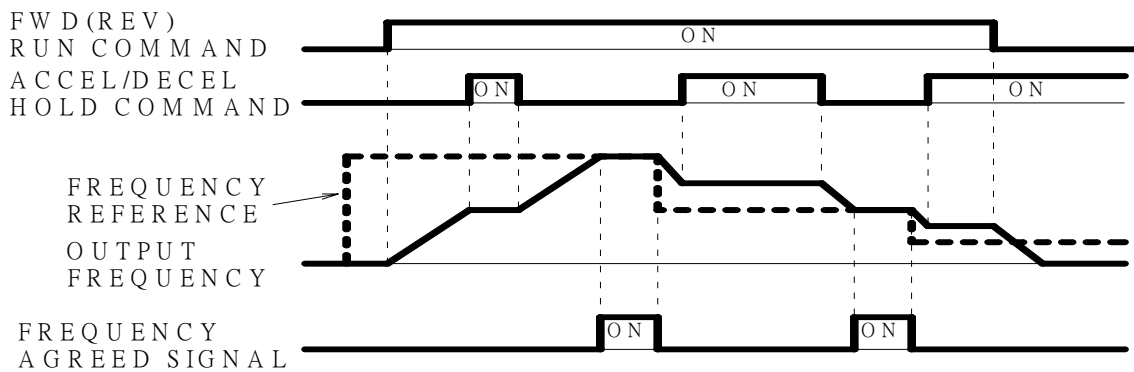

* When the FWD (REV) run command is input along with the accel/decel hold command, the motor does not operate. However, when frequency reference lower limit (F034) is set greater than or equal to min. output frequency (F016), the motor operates at frequency reference lower limit.

○ **LOCAL/REMOTE Selection (F052=17)**

Select operation reference either by the digital operator or by multi-function input terminals. LOCA/REMOTE select is available only during stop.

Open: Run according to the setting of run command selection (F003) or frequency reference selection (F004).

Closed: Run by frequency reference and run command from the digital operator.

(Example) Set F003 = 1, F004 = 2, F008 = 0. In LOCAL mode, frequency reference is according to frequency selection at LOCAL(F008)

Open: Run by frequency reference from multi-function input (terminal FR, PS) and run command from multi-function input terminals S1 to S7.

Closed: Run by potentiometer frequency reference and run command from the digital operator.

- **Communication/Multi-function Input Terminal Selection Input (F052=18)**
 Operation can be changed from communication command, or from multifunction input terminal or digital operator command.
 Run command from communication and frequency reference are effective when multi-function input terminal for this setting is “Closed .”
 Run command in LOCAL/REMOTE mode and frequency reference are effective when “Open.”

- **UP/DOWN Command (F052=34)**
 With the FWD (REV) run command entered, accel/decel is enabled by inputting the UP or DOWN signals to multi-function input terminals S6 and S7 without changing the frequency reference, so that operation can be performed at the desired speed.
 When UP/DOWN commands are specified by F056, any function set to F055 becomes disabled; terminal S6 becomes an input terminal for the UP command and terminal S7 for the DOWN command.

Multi-function input terminal S6 (UP command)	Closed	Open	Open	Closed
Multi-function input terminal S7 (DOWN command)	Open	Closed	Open	Closed
Operation status	Accel	Decel	Hold	Hold

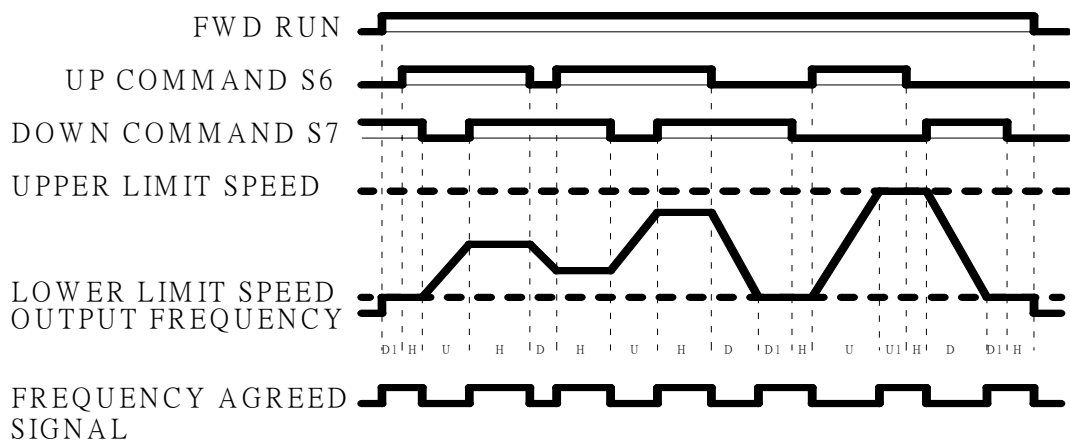

U=UP(accelerating) status
 D=DOWN(deceleration) status
 H=HOLD(constant speed)status
 U1=UP status,clamping at upper limit speed
 D1=DOWN statue,clamping at lower limit speed

Notes :

1. When UP/DOWN command is selected, the upper limit speed is set.
 Upper limit speed = Maximum output frequency (F011)
 \times Frequency reference upper limit F033/100
2. Lower limit value is either minimum output frequency (F016) or frequency reference lower limit (F034) (whichever is larger.)

-
3. When the FWD (REV) run command is input, operation starts at the lower limit speed without an UP/DOWN command.
 4. If the jog command is input while running by the UP/DOWN command, the jog command has priority.
 5. Multi-step speed reference 1 to 4 is not effective when UP/DOWN command is selected. Multi-step speed reference is effective during running in hold status.
 6. When "1" is set for HOLD output frequency memory selection (F100), output frequency can be recorded during HOLD.

F100 Setting	Description
0 (Initial setting)	Output frequency is not recorded during HOLD.
1	When HOLD status is continued for 5 seconds or longer, the output frequency during HOLD is recorded and the inverter restarts at the recorded frequency.

- **Communication Self Test (F052=35)**
Please refer to page 96.

F057: TERMINAL MA-MB-MC
F058: TERMINAL P1 SELECT
F059: TERMINAL P2 SELECT

- **Using Output Signal (F057, F058, F059)**
Multi-function output terminal MA-MB, P1 and P2 functions can be changed by setting constants F057, F058, and F059.
 - Terminal MA-MB functions : Set to F057
 - Terminal P1 function : Set to F058
 - Terminal P2 function : Set to F059

Setting	Name	Description	Ref.
0	Fault	Closed when inverter fault occurs.	—
1	In operation	Closed when either FWD/REV command is input or voltage is output from the inverter.	—
2	Agreed frequency	Closed when setting frequency agrees with inverter output frequency.	64
3	Zero speed	Closed when inverter output frequency is less than minimum output frequency.	—
4	Frequency detection 1	Output frequency \geq frequency detection level (F095)	77
5	Frequency detection 2	Output frequency \leq frequency detection level (F095)	77
6	Overtorque detection (a contact output)	—	78
7	Overtorque detection (b contact output)	—	78
8	Undertorque detection (a contact output)	—	85
9	Undertorque detection (b contact output)	—	85
10	Minor fault(alarm)	Closed when the alarm is indicated.	—
11	Base blocked	Closed when the inverter output is shut off.	—
12	LOCAL operation mode	Closed when “LOCAL” is selected by LOCAL/REMOTE selection.	—
13	Inverter operation ready	Closed when inverter fault is not detected, and operation is ready.	—
14	Fault restart	Closed during fault retry	—
15	In UV	Closed when undervoltage is detected.	—
16	In reverse run	Closed during reverse run.	—
17	In speed search	Closed when inverter conducts speed search.	—
18	Data output from communication	Operates multi-function output terminal by MODBUS communication.	94
19	PID feedback loss	Closed during PID feedback loss	89
20	Frequency reference signal loss	Closed during frequency reference signal loss	65
21	Inverter overheat alarm	Closed when overheat alarm is indicated.	58

● **Initial Setting of Multi-Function Output Terminal**

Constants No.	Terminal	Initial setting
F057	MA, MB	0 (fault)
F058	P1	1 (in operation)
F059	P2	2 (frequency agreed)

○ **Frequency Agreed Signal (F057=2)**

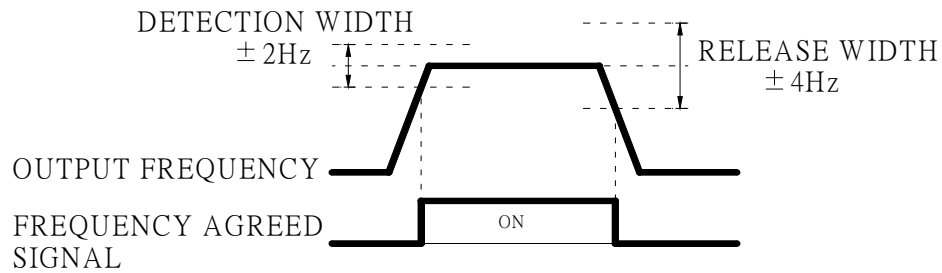

F060: ANALOG FREQUENCY REFERENCE GAIN
F061: ANALOG FREQUENCY REFERENCE BIAS
F062: ANALOG REFQUENCY REFERENCE FILTER

○ **Adjusting Speed Setting Signal**

To provide frequency reference by analog input of control circuit terminal FR or FC, the relationship between analog input and frequency reference can be set. Analog frequency reference gain (F060) The max. frequency reference (F011) provided when analog input is max. can be set in units of 1%. (Max. output frequency F011=100%)
 Factory setting: 100%

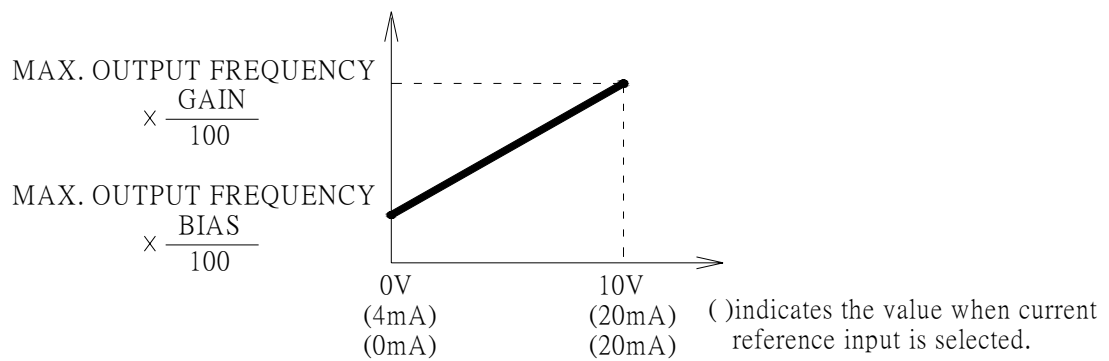

Analog frequency reference bias (F061)

The frequency reference provided when analog input is 0V (4mA or 0mA) can be set in units of 1%. (Max. output frequency F011=100%)
 Factory setting: 0%

Typical Setting

(1) To operate the inverter with frequency reference of 0% to 100% at 0 to 5V input.

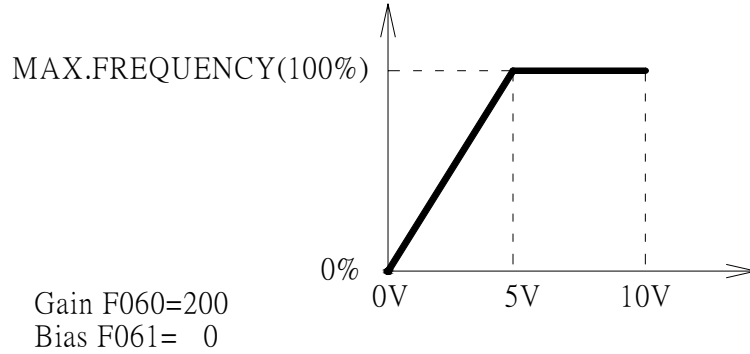

(2) To operate the inverter with frequency reference of 50% to 100% at 0 to 10V input.

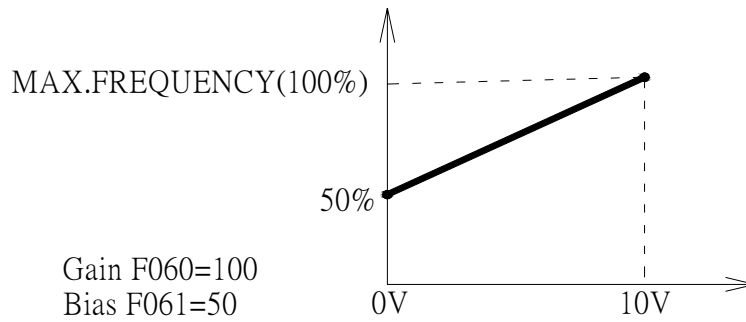

F064: FREQUENCY LOSS DETECTION

Use this setting to select the processing performed if the level of the frequency reference signal from the control circuit terminals suddenly drops.

F064 Setting	Description
0	Processing for frequency reference loss disabled
1*	Processing for frequency reference loss enabled

*Processing for frequency reference loss is enabled when the frequency reference selection (F004=2, 3, 4, 5) and constant F064 is set to 1.

Processing Method when 1 is Selected

If the level of the frequency reference signal drops by 90% within 400ms, operation continues at 80% of the signal level before the level drops.

F065: MONITOR OUTPUT TYPE

- **Using Analog Output (AM-AC) As A Pulse Train Signal Output**
Analog output AM-AC can be used as a pulse train output (output frequency monitor). Set F065 to 1 when using pulse train output.

F065 setting	Description
0 (Initial setting)	Analog monitor output
1	Pulse monitor output

F066: MONITOR ITEM SELECT

- **Using Frequency Meter or Ammeter**
Selects to output either output frequency or output current to analog output terminals AM-AC for monitoring.

F066 setting	Description
0	Output frequency
1	Output current
2	Main circuit DC voltage
3	Torque monitor
4	Output power
5	Output voltage reference

In initial setting, analog voltage of approx. 10V is output when output frequency (output current) is 100%.

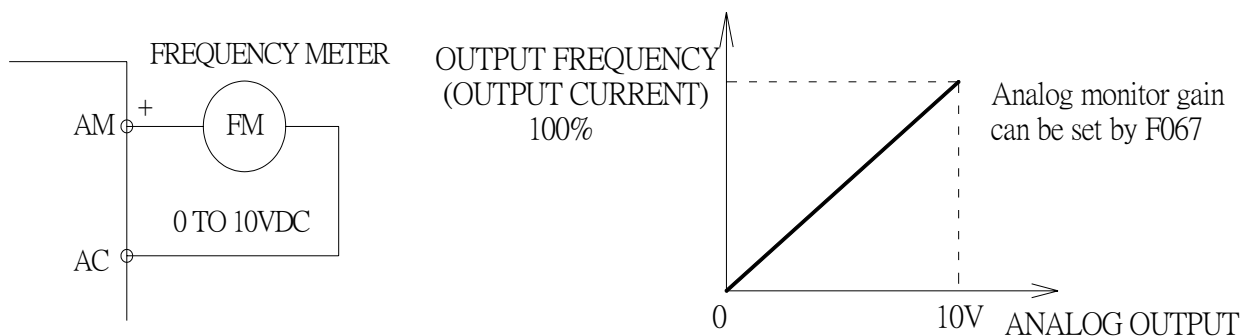

F067: ANALOG MONITOR GAIN

- **Calibrating Frequency Meter or Ammeter**
Used to adjust analog output gain

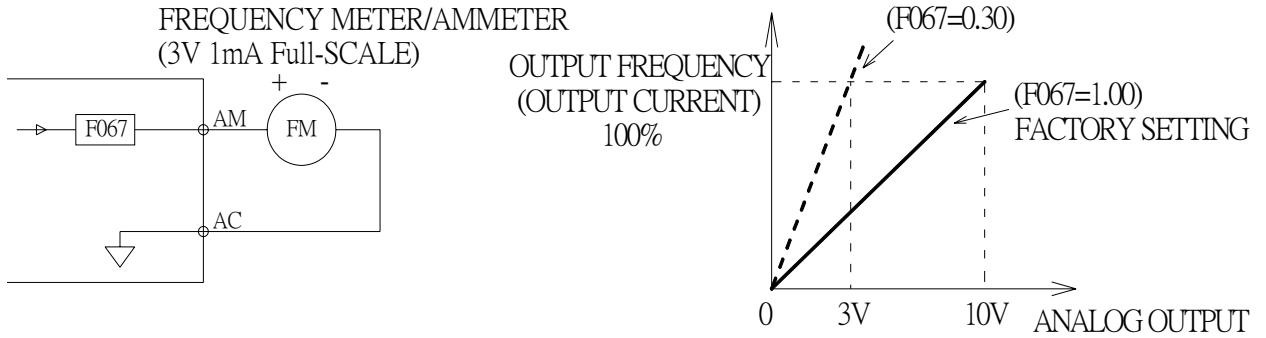

Example: Set the analog output voltage at 100% of output frequency (output current).
Frequency meter displays 0 to 60Hz at 0 to 3V. $10 \times F067$ setting (0.30)=3V.

- F068: OPERATOR(V) REFERENCE GAIN**
- F069: OPERATOR(V) REFERENCE BIAS**
- F070: OPERATOR(V) REFERENCE FILTER**
- F071: OPERATOR(I) REFERENCE GAIN**
- F072: OPERATOR(I) REFERENCE BIAS**
- F073: OPERATOR(I) REFERENCE FILTER**

EL-550 Operator Analog Speed Reference Block Diagram

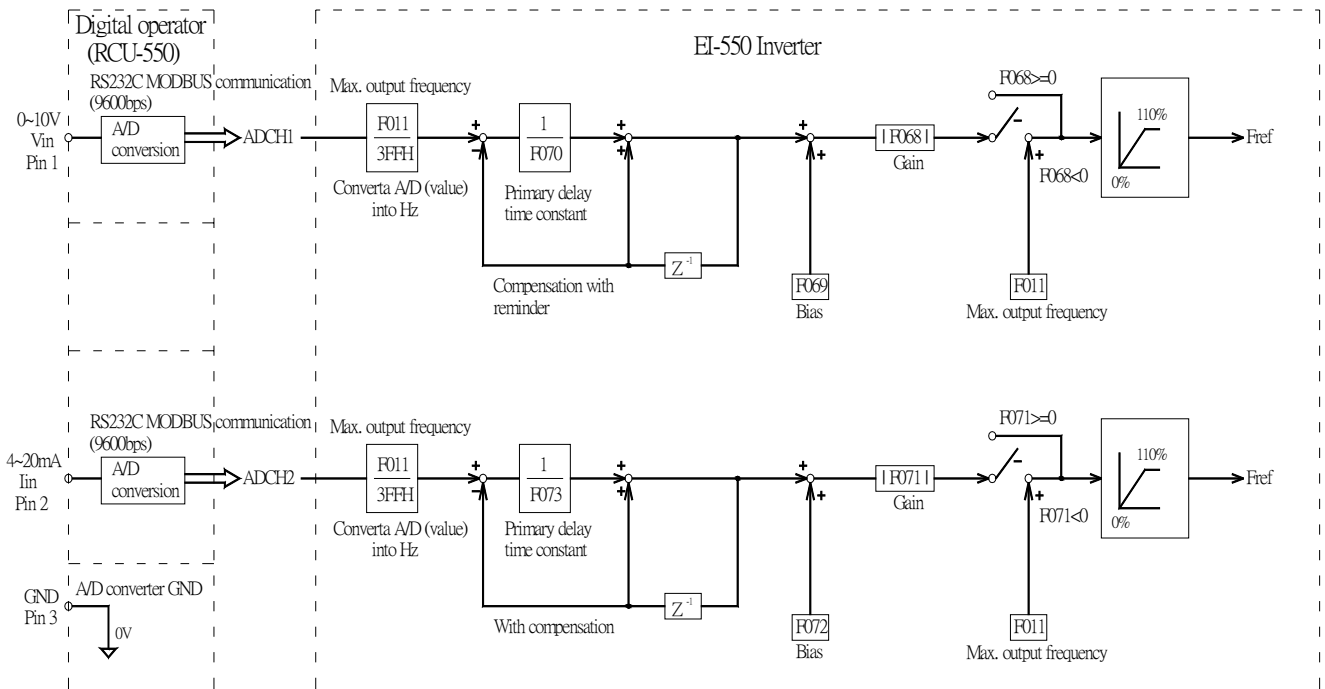

F074: PULSE TRAIN GAIN
F075: PULSE TRAIN BIAS
F076: PULSE TRAIN FILTER

F077: OPERATOR ANALOG INPUT FUNCTION
F078: OPERATOR ANALOG INPUT SIGNAL SELECTION
F079: OPERATOR ANALOG INPUT FREQUENCY BIAS

○ **Using Multi-function Analog Input of Digital Operator RCU-550 (F077, F078, F079)**

The input analog signal (0 to 10V or 4mA to 20mA) of the digital operator RCU-550 can be used as an auxiliary function for the main speed frequency reference input to the control circuit terminals (FR or PS).

****Note:** When using the signal of digital operator RCU-550 as a multi-function analog input, never use it for the target value or the feedback value of PID control.

****Note:** RCU-550 analog voltage input terminal=KV terminal, analog current input terminal=KI terminal, analog input common for KV and KI=KC.

RCU-550 multi-function input selection

F077 Setting	Function	Description
0	Disabled	Digital operator RCU-550 multi-function input is disabled (Initial setting)
1	Auxiliary frequency reference (FREE2)	When frequency reference 2 is selected in multi-step speed reference, the analog signal input for current or voltage of RCU-550 becomes frequency reference. The F025 setting becomes invalid. **Set frequency reference gain to F068 or F071 frequency reference bias to F069 or F072
2	Frequency reference gain (FGAIN)	Set the FGAIN to constant F060 or F074 and the FBIAS to constant F061 to F075 for the main speed frequency reference. Then, multiply the resulting frequency reference by the FGAIN
3	Frequency reference bias (FBIAS)	Set the FGAIN to constant F060 or F074 and the FBIAS to constant F061 or F075 for the main speed frequency reference. Then, add the FBIAS to the resulting frequency reference. The amount of the FBIAS to be added is set to F079.
4	Output voltage bias (VBIAS)	Add the VBIAS to the output voltage after V/F conversion.

(1)Auxiliary frequency reference(F077=1)

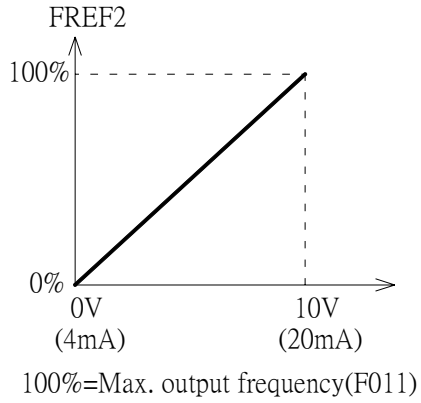

(2)Frequency reference gain(F077=2)

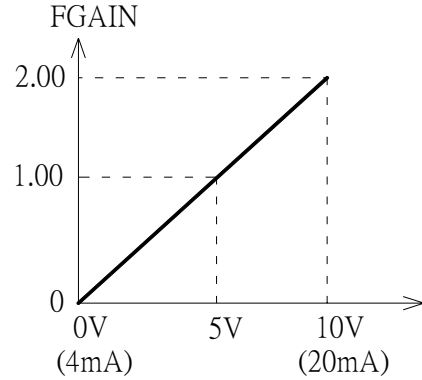

(3)Frequency reference bias(F077=3)

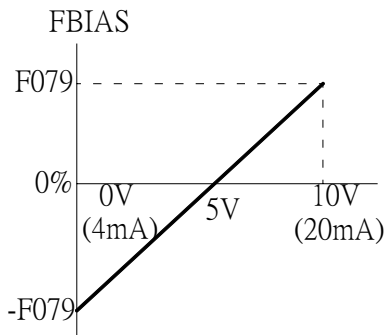

(4)Output voltage bias(F077=4)

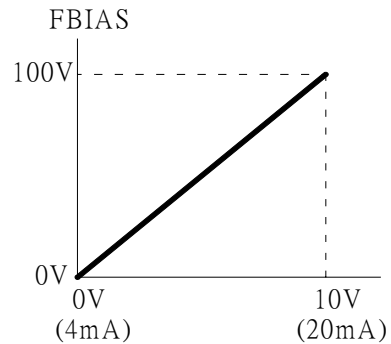

The VBIAS value to be added is doubled for 440V class inverters.

Multi-function analog input signal selection

F078 Setting	0	1
Description	RCU-550 analog voltage input 0~10V (Initial setting)	RCU-550 analog current input 4~20mA

Frequency reference bias setting

F079 Initial setting	Unit	Setting range
10	%	0 ~ 50 { 100%/ Max. output frequency (F011) }

F080: CARRIER FREQUENCY

Set inverter output transistor switching frequency (carrier frequency F080).

F080 Setting	Carrier frequency	Metallic noise from motor	Noise current leakage
7	12 f _{out} (HZ)	Higher ↑↓ Not audible	Smaller ↑↓ Larger
8	24 f _{out} (HZ)		
9	36 f _{out} (HZ)		
1	2.5 (kHz)		
2	5.0 (kHz)		
3	7.5 (kHz)		
4	10.0 (kHz)		

Setting values 7, 8, or 9 multiplies output frequency according to output frequency value.

F080=7

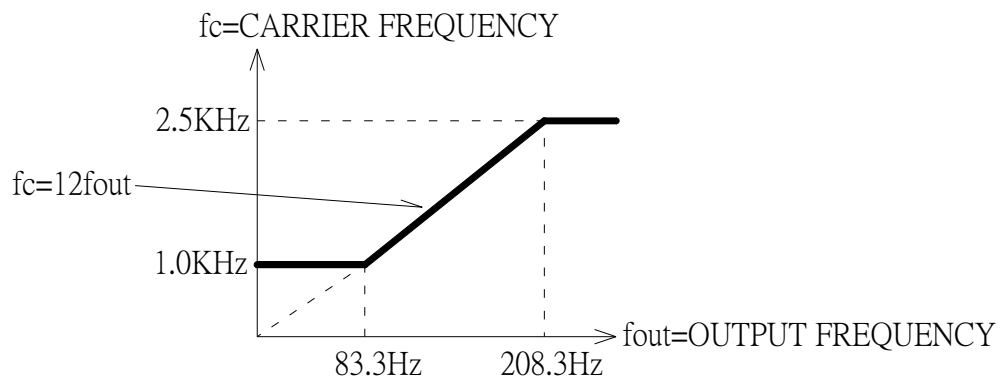

F080=8

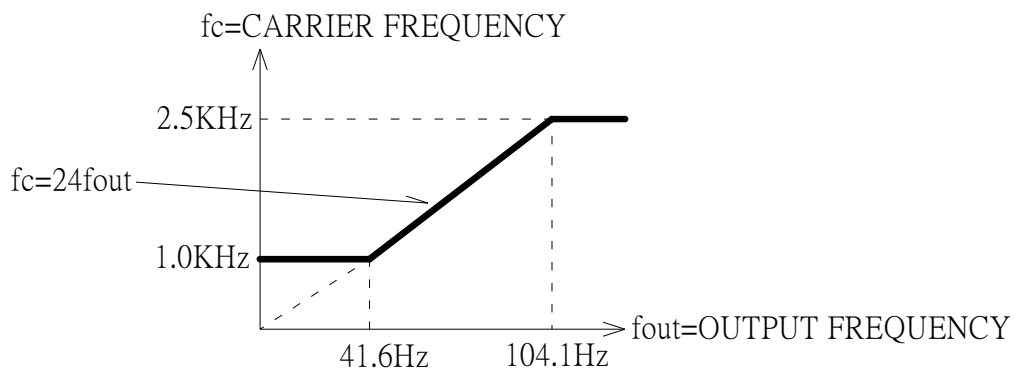

F080=9

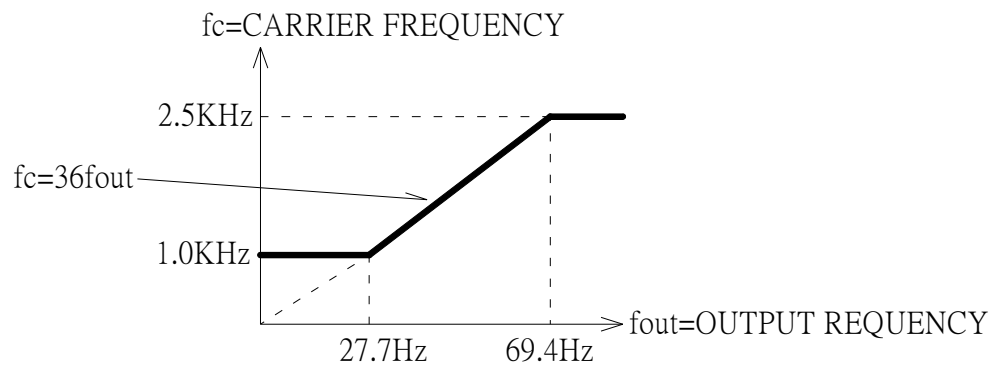

Factory setting varies according to inverter capacity.

Voltage Class (V)	Capacity (HP)	F080 Initial setting		Max. continuous output current (A)	Reduced current at carrier frequency 10kHz
		Setting	Carrier Frequency		
220V 3-phase	1	4	10kHz	5.0A	—
	2	3	7.5kHz	8.0A	7.0A
	3	3	7.5kHz	11.0A	10.0A
	5	3	7.5kHz	17.5A	16.5A
	7 1/2	3	7.5kHz	25A	23A
	10	3	7.5kHz	33A	30A
440V 3-phase	1	3	7.5kHz	3.4A	3.0A
	2	3	7.5kHz	4.8A	4.0A
	3	3	7.5kHz	5.5A	4.8A
	5	3	7.5kHz	8.6A	8.1A
	7 1/2	3	7.5kHz	14.8A	14A
	10	3	7.5kHz	18A	17A

**Note: Reduce continuous output current when changing carrier frequency to 4 (10 kHz) for the 220V class, 2HP or more and 440V class inverters. Refer to the table above for the reduced current.

**Note: If the wiring distance is long, reduce the inverter carrier frequency as described below.

Wiring distance between inverter and motor	Up to 50m	Up to 100m	More than 100m
Carrier frequency (F080 setting)	10kHz or less (F082=1, 2, 3, 4, 7, 8, 9)	5kHz or less (F080=1, 2, 7, 8, 9)	2.5kHz or less (F080=1, 7, 8, 9)

**Note: When using vector control mode (F002=1), set carrier frequency selection (F080) to either 1, 2, 3, 4. Do not set to 7, 8, or 9.

**Note: Carrier frequency is automatically reduced to 2.5kHz when reducing carrier frequency selection at low speed (F175) is set to 1 and output frequency $\leq 5\text{Hz}$; Output current $\geq 110\%$.

**Note: F175 Factory Setting: 0 (Disabled).

F081: POWER LOSS SELECTION

○ Automatic Restart after Momentary Power Loss (F081)

F081 Setting	Description
0 (Initial setting)	Continuous operation after momentary power loss not provided
1*	Continuous operation after power recovery within momentary power loss ridethru time 0.5s
2	Continuous operation after power recovery (Fault output not provided)

* Hold the operation signal to continue the operation after recovery from a momentary power loss.

F082: AUTO RETRY ATTEMPTS

○ Continuing Operation by Automatic Fault Reset (F082)

Set the inverter to restart and reset fault detection after a fault OC(overcurrent), OV(overvoltage) occurs. The number of self-diagnosis and retry attempts can be set at F082 up to 10.

The number of retry attempts are cleared to 0 in the following cases :

- (1) If no other fault occurs within 10 minutes after retry
- (2) When the fault reset signal is ON after the fault is detected
- (3) Power supply is turned OFF

F083: JUMP FREQUENCY 1

F084: JUMP FREQUENCY 2

F085: JUMP FREQUENCY 3

F086: JUMP BANDWIDTH

○ Jump Frequencies (F083 to F086)

This function allows the prohibition or “jumping” of critical frequencies so that the motor can operate without resonance caused by machine systems.

Jump Frequency 1 (F083)

Jump Frequency 2 (F084)

Jump Frequency 3 (F085)

Jump Bandwidth (F086)

OUTPUT FREQUENCY

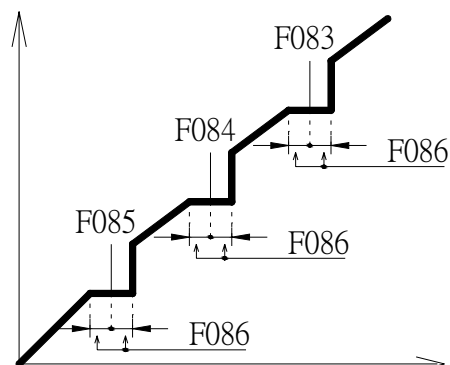

$$F083 \geq F084 \geq F085$$

If this condition is not satisfied the inverter displays "Err" for one second and restores the data to original settings.

F089: DC INJECTION BRAKING CURRENT**F090: DC INJECTION TIME @STOP****F091: DC INJECTION TIME @START**

○ **Applying DC Injection Braking**

DC Injection Braking Current (F089)

Set DC injection braking current in units of 1%. (Inverter rated current=100%)

DC Injection Braking Time at Stop (F090)

Set DC injection braking time at stop in units of 0.1s.

When the setting is 0, DC injection braking is not performed but inverter output is shut OFF (Base Block) at the timing of DC injection braking start.

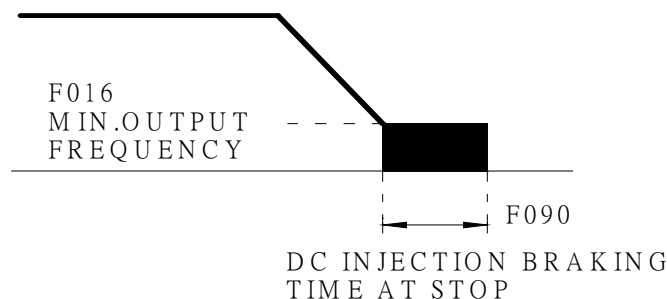

When coasting to a stop is specified in stopping method selection (F005=1), DC injection braking at stop does not operate.

○ **DC Injection Braking at Start (F089, F091)**

Restarts a coasting motor after stopping it. Set the DC injection braking time at start in F091 in units of 0.1 second. Constant F089 is DC injection braking current value. When the setting of F091 is "0", DC injection braking is not performed and acceleration starts from the minimum output frequency. When F089 is set to 0, acceleration starts from the minimum output frequency after the baseblocking for F091 setting time.

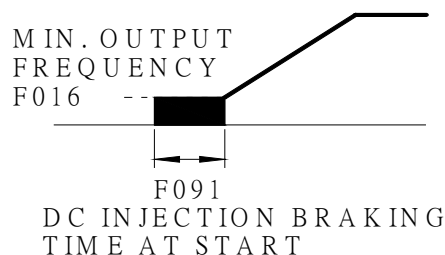

F092: STALL PREVENTION@DECELERATION

Stall Prevention during Deceleration (F092)

To prevent overvoltage during deceleration, the inverter automatically extends the deceleration time according to the value of main circuit DC voltage. When using an optional braking resistor, set F092 to 1.

F092 Setting	Stall prevention during deceleration
0 (Initial setting)	Provided
1	Not Provided (when braking resistor mounted)

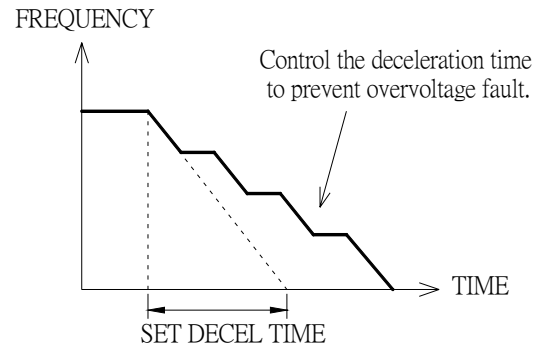

F093: STALL PREVENTION@ACCELERATION F094: STALL PREVENTION LEVEL@RUN

○ Preventing Motor from Stalling (Current Limit)

Automatically adjusts the output frequency and output current according to the load to continue operation without stalling the motor.

Stall Prevention (Current Limit) Level during Acceleration (F093)

Stall prevention (current limit) level during acceleration (F093) sets the stall prevention (current limit) level during acceleration in units of 1%. (Inverter rated current = 100%)

※ Factory setting: 170%. A setting of 200% disables the stall prevention (current limit) during acceleration.

During acceleration, if the output current exceeds the value set for F093, acceleration stops and frequency is maintained. When the output current goes down to the value set for F093, acceleration starts.

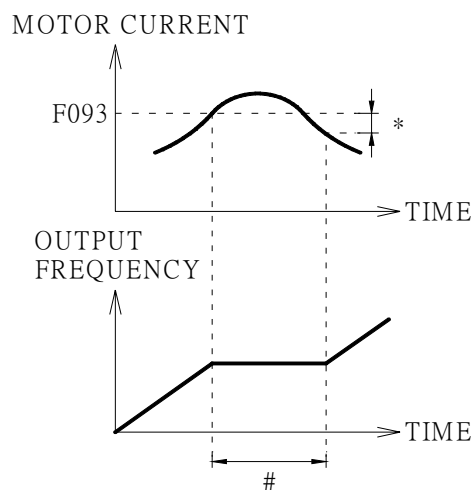

*Stops the acceleration to prevent the motor from stalling.

#Release width (hysteresis) of stall prevention during accel is approx. 5% of inverter rated current.

In the constant output area [output frequency \geq max. voltage output frequency (F013)], following equation automatically decreases the stall prevention (current limit) level during acceleration.

Stall prevention (current limit) level during accel in constant output area

$$= \text{Stall prevention (current limit) level during accel (F093)} \times \frac{\text{Max. voltage output frequency (F013)}}{\text{Output frequency}}$$

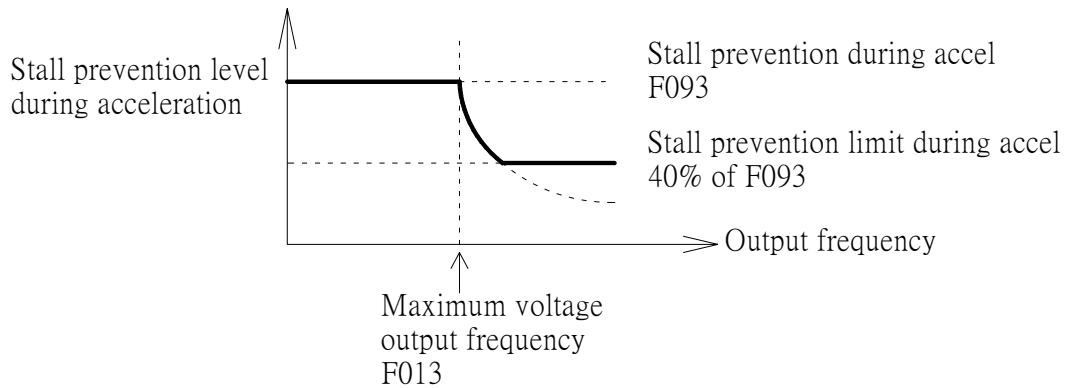

Stall Prevention (Current Limit) Level during Running (F094)

Sets the stall prevention (current limit) level during running in units of 1%. (Inverter rated current = 100%)

※ Factory setting: 160%. A setting of 200% disables the stall prevention (current limit) during running.

If stall prevention action current at agreed speed exceeds the value set for F094 for longer than 100msec, deceleration starts.

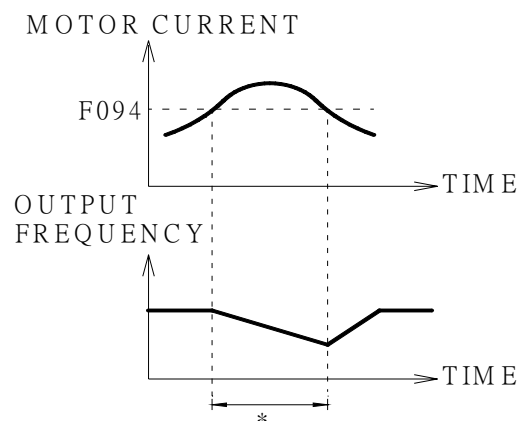

*Decreases frequency to prevent the motor from stalling.

F095: FREQUENCY DETECTION

- **Frequency Detection (F095)**
Frequency detection is effective when either of output terminal function selections F057, F058 or F059 are set to 4 or 5.

- **Frequency Detection 1**
(Output frequency \geq Frequency detection level F095)
(Set either of F057, F058 or F059 to 4)

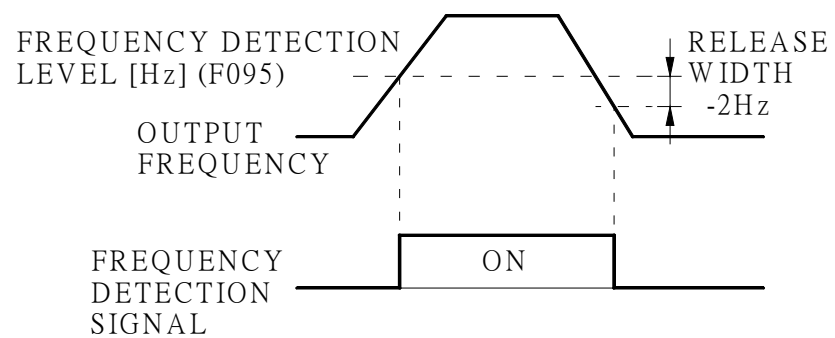

- **Frequency Detection 2**
(Output frequency \leq Frequency detection level F095)
(Set either of F057, F058 or F059 to 5)

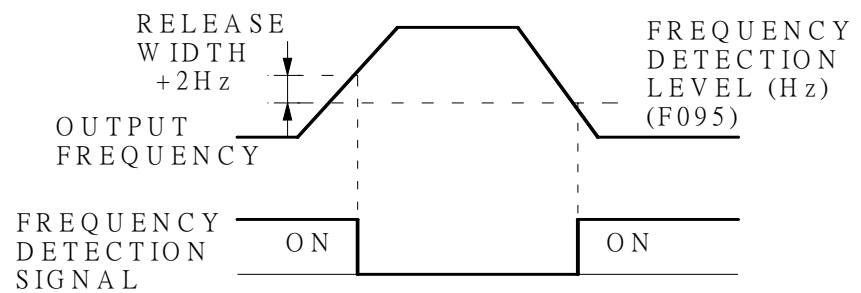

F096: OVERTORQUE DETECTION 1

F096 Setting	Description
0 (Initial setting)	Overtorque detection not provided
1	Detected during constant-speed running, and operation continues after detection.
2	Detected during constant-speed running, and operation stops after detection.
3	Detected during running, and operation continues after detection.
4	Detected during running, and operation stops after detection.

- (1) To detect overtorque at accel/decel, set to 3 or 4.
- (2) To continue the operation after overtorque detection, set to 1 or 3. During detection, the digital operator displays “oL3” alarm.
- (3) To halt the inverter by a fault at overtorque detection, set to 2 or 4. At detection, the digital operator displays “oL3” fault .

F097: OVER/UNDERTORQUE DETECTION 2**Over/Undertorque Selection 2 (F097)**

When vector control mode is selected, over/undertorque detection can be performed either by output current or by output torque.

When V/F control mode is selected, F097 setting becomes invalid, and over/undertorque is detected by output current.

F097 Setting	Description
0	Detected by output torque
1	Detected by output current

F098: OVERTORQUE DETECTION LEVEL**F099: OVERTORQUE DETECTION TIME****Overtorque Detection Level (F098)**

Sets the overtorque detection current level in units of 1%. (Inverter rated current = 100%).

Factory setting: 160%

Overtorque Detection Time (F099)

If the time when motor current exceeds the overtorque detection level (F098) is longer than overtorque detection time (F099), the overtorque detection function operates.

Factory setting : 0.1sec.

○ **Torque Detection**

If an excessive load is applied to the machine, output current increase can be detected to output alarm signals to multi-function output terminals (MA-MB, P1 and P2).

To output an overtorque detection signal, set output terminal function selection F057 to F059 to “overtorque detection” [Setting: 6 (a contact) or 7 (b contact)].

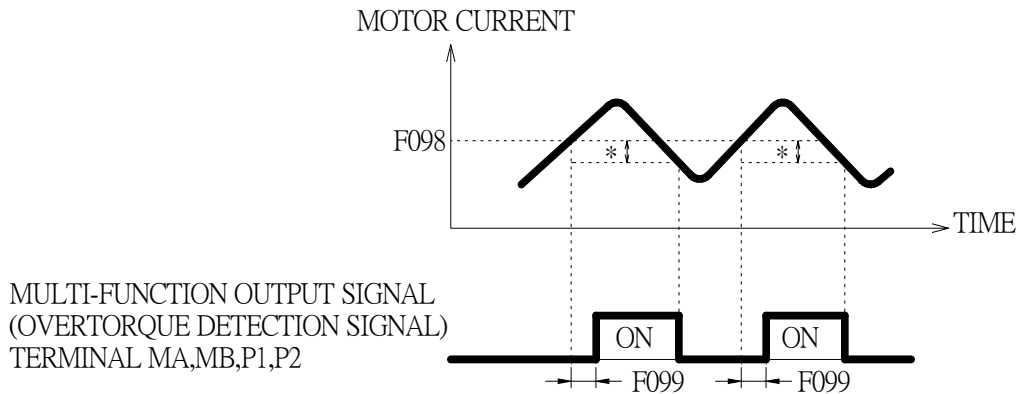

*Overtorque detection release width (hysteresis) is set at approx. 5% of inverter rated current.

F100: HOLD OUTPUT FREQUENCY SAVING

F100 Setting	Description
0	Output frequency is not recorded during HOLD.
1	When HOLD status is continued for 5 seconds or longer, the output frequency during HOLD is recorded and the inverter restarts at the recorded frequency.

Please refer to page 62.

F101: SPEED SEARCH DECELERATION TIME

F102: SPEED SEARCH LEVEL

○ **Operating Coasting Motor without Trip**

To operate coasting motor without trip, use the speed search command or DC injection braking at start.

Speed search command:

Restarts a coasting motor without stopping it. This function enables smooth switching between motor commercial power supply operation and inverter operation.

Set multi-function input selection (F050 to F056) to 14 (search command from maximum output frequency) or 15 (search command from set frequency).

Build a sequence so that FWD (REV) run command is input at the same time as the search command or after the search command. If the run command is input before the search command, the search command becomes disabled.

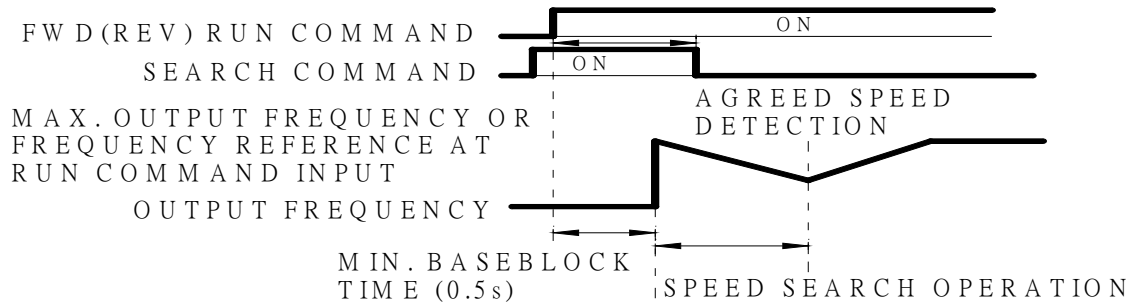

The deceleration time of speed search command can be set F101. If the setting is 0 sec., the inverter will still have 2.0 sec. as speed search time. When inverter output current is larger or equal to speed search current level (F102), speed search command starts.

F103: TORQUE COMPENSTAIION GAIN
F104: TORQUE COMPENSATION TIME

Full-Range Automatic Torque Boost (When V/F Mode Is Selected F002=0)

Motor torque requirement changes according to load conditions. Full-range automatic torque boost adjusts voltage of V/F pattern according to the requirement. EI-550 automatically adjusts the voltage during constant-speed operation as well as acceleration. The required torque is calculated by the inverter and this ensures triples operation and energy-saving effects.

$$\boxed{\text{Output voltage}} \propto \boxed{\text{Torque compensation gain (F103)}} \times \boxed{\text{Required torque}}$$

Operation

Normally, no adjustment is necessary for torque compensation gain (F103 factory setting : 1.0). When the wiring distance between the inverter and the motor is long, or when the motor generates vibration, change the automatic torque boost gain. In these cases, set the V/F pattern (F011 to F017).

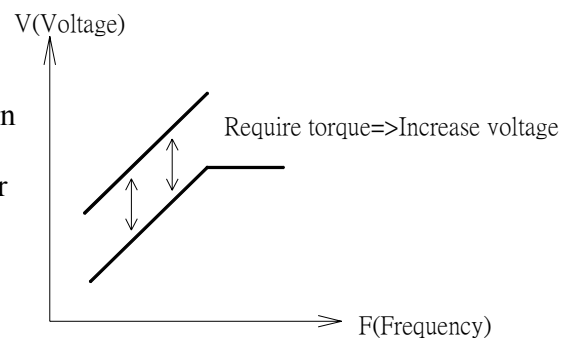

Adjustment of torque compensation time constant (F104) and torque compensation iron loss (F105) are normally not required. However, when the motor generates vibration, increase the setting of F104 and when response is low, reduce the setting of 104.

F105: TORQUE COMPENSATION IRON LOSS

According to different inverter capacity, the initial setting varies. Please refer to page 38.

F106: MOTOR RATED SLIP F107: TERMINAL RESISTANCE F108: LEAKAGE INDUCTANCE

■ Using Vector Control Mode

Setting the control mode selection (F002) can use a vector control mode.

F002 = 0: V/F control mode (factory setting)

1: Vector control mode

○ Precaution for Vector Control Application

Since vector control needs motor constants, the standard motor constants have been set at the factory prior to shipment. Therefore, when an inverter exclusive-use motor is used or when a motor of any other manufacturer is driven the required torque characteristics or speed control characteristics may not be maintained because the constants are not matched. Set the following constants so that they can match the motor constants.

Constant No.	Name	Unit	Setting range	Initial setting
F106	MOTOR RATED SLIP	0.1 HZ	0.0 ~ 20.0 HZ	According to different inverter capacity, the initial setting varies. Please refer to page 38.
F107	LINE TO NEUTRAL (PER PHASE)	0.001 Ω (less than 10 Ω) 0.01 Ω (10 Ω or more)	0.0000 ~ 65.50 Ω	
F036	MOTOR RATED CURRENT	0.1 A	0 ~ 150%	
F110	MOTOR NO-LOAD CURRENT	1%	0 ~ 99%	

** Setting depends on inverter capacity. However, set F107 to be 1/2 2-phase measuring value (in condition of motor Y wire connecting)**

○ Motor Constant Calculation

$$(1) \text{ Motor rated slip (F106)} = \frac{\text{Motor constant speed} - \text{Motor rated speed (r/min)}}{120 / \text{Number of motor pole}} \text{ (HZ)}$$

$$\text{(Ex.) Motor rated slip} = \frac{1800 - 1763 \text{ (rpm)}}{120 / 4} = 1.2 \text{ (HZ)}$$

$$(2) \text{ Line to neutral (per phase)(F107)} = \frac{\text{According to line to line resistance at insulation grade}}{\times} \frac{273 + (25^\circ\text{C} + \text{insulation grade temp.})/2}{273 + \text{insulation grade temp.}}$$

$$\text{(Ex.) } 0.145 \times \frac{273 + (25 + 115) / 2}{273 + 115} = 0.128 \Omega$$

(3) Motor rated current (F036)= Rated current at motor rated frequency

$$\text{(4) Motor no-load current (F110)} = \frac{\text{No-load current at motor rated frequency}}{\text{Rated current at motor rated frequency}} \times 100\%$$

(Ex.) 11.7 (A) /43.0 (A)=27%

Set F106, F107, F039 and F110 according to the motor test report. To connect a reactor between the inverter and the motor, set F108 to the value of F108 (motor leakage inductance) initial value plus externally mounted reactor inductance. Unless a reactor is connected, F108 does not have to be set according to the motor.

Adjustment of torque compensation gain (F103) compensation time constants (F104) is normally not required. Adjust torque compensation time constant under the conditions:

- Increase the setting when the motor generates vibration.
- Reduce the setting when response is low.

To adjust for slip compensation gain (F111), induce load so speed reaches target value. Increase or decrease the value

- When speed is less than target value, increase slip compensation gain.
- When speed is more than target value, reduce slip compensation gain.

Adjustment of slip compensation time constant (F112) is required. Adjust under the following conditions:

- Reduce the setting when response is low.
- Increase the setting when speed is unstable.

○ **V/F Pattern during Vector Control**

Set V/F pattern as follows during vector control. The following examples are for 220V class motors. When using 440V class motors, double the voltage settings (F012, F015, F017).

Standard V/F

[MOTOR SPECIFICATION 60HZ]

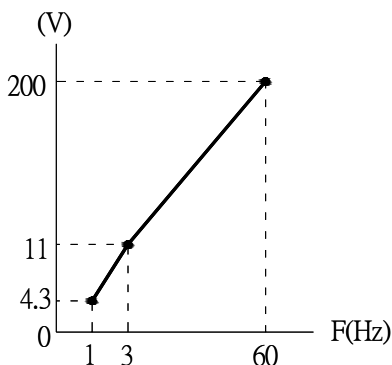

[MOTOR SPECIFICATION 50HZ]

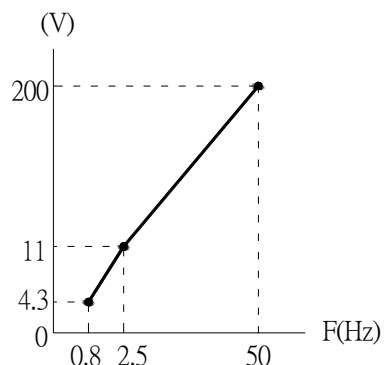

High Starting Torque V/F

[MOTOR SPECIFICATION 60HZ]

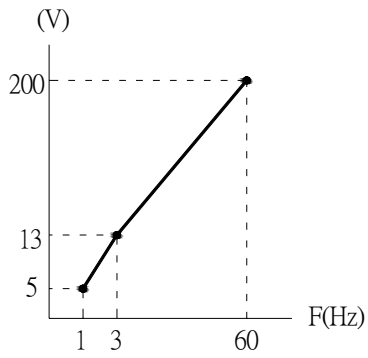

[MOTOR SPECIFICATION 50HZ]

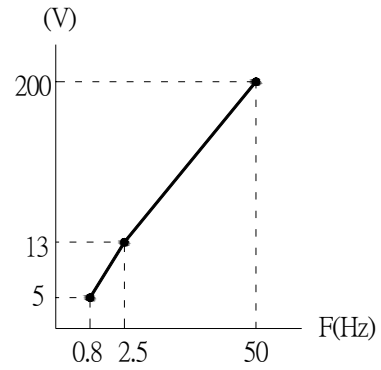

When operating with frequency larger than 60HZ/50HZ, change only max. output frequency (F011).

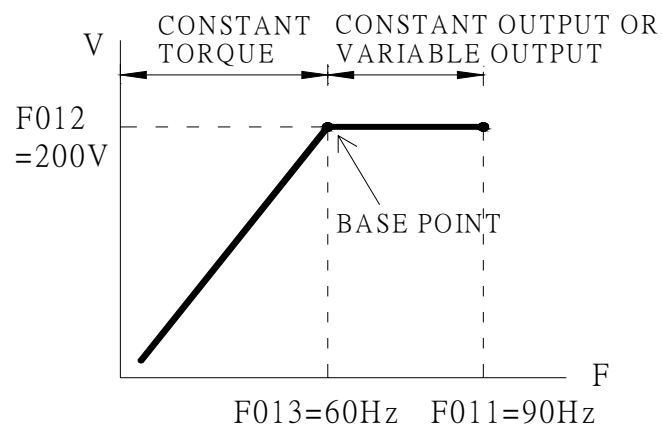

F109: TORQUE COMPENSATION VOLTAGE LIMIT

- **The Setting Range of F109 Torque Compensation Voltage Limit Is 0~250%**
F109 Factory setting =150%

F110: NO-LOAD CURRENT F111: SLIP COMPENSATION GAIN F112: SLIP COMPENSATION TIME F113: SLIP COMPENSATION REGENERATION

■ Decreasing Motor Speed Fluctuation

- **Slip Compensation (When F002 Is Set to 0 in V/F Control Mode)**

As the load becomes larger, motor speed is reduced and motor slip value is increased.

The slip compensating function controls the motor speed at a constant value even if the load varies.

When inverter output current is equal to the motor rated current F036, the compensation frequency is added to the output frequency.

Compensation frequency = Motor rated slip (F106)

$$\times \frac{\text{Output current} - \text{Motor no-load current (F110)}}{\text{Motor rated current (F036)} - \text{Motor no-load current (F110)}}$$

$$\times \text{Slip compensation gain (F111)}$$

Related constants

Constants No.	Name	Unit	Setting range	Initial setting
F036	MOTOR RATED CURRENT	0.1A	0 ~ 150% of inverter rated current	*
F111	SLIP COMPENSATION GAIN	0.1	0.0 ~ 2.5	0.0
F110	MOTOR NO-LOAD CURRENT	1%	0 ~ 99%(100%=Motor rated current)	*
F112	SLIP COMPENSATION TIME	0.1s	0.0 ~ 25.5s	2.0s
F106	MOTOR RATED SLIP	0.1Hz	0.0 ~ 20.0HZ	*

* Differs depending on inverter capacity.

- Notes: 1. Slip compensation is not performed at output frequency < minimum output frequency (F016).
2. Slip compensation is not performed during regeneration.
3. Slip compensation is not performed when motor rated current (F036) is set to 0.0A.

F115: STALL PREVENTION AUTO DECREASE
F116: STALL PREVENTION ACCEL/DECEL

○ **Stall Prevention during Operaton**

Stall Prevention Automatic Dcrease Selection (F115)

F115 Setting	Description
0 (Initial setting)	The stall prevention level becomes the level set for the constant F094 in all frequency areas.
1	The stall prevention level is automatically decreased in the constant output range (Max. frequency > Max. voltage output frequency). The lower limit is 40% of the set value of F094.

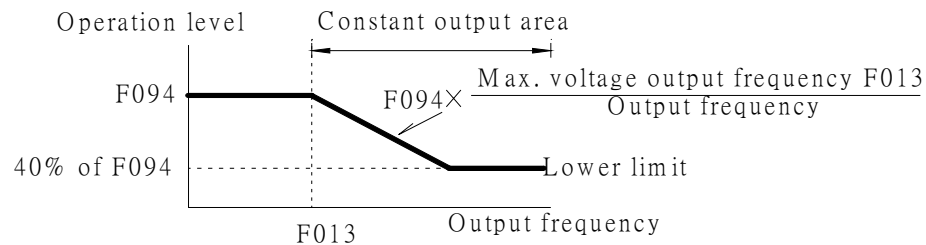

Accel/Decel Time Selection during Stall Prevention (F116)

F116 Setting	Description
0 (Initial setting)	Accel/decel time is set by accel/decel time 1 or 2.
1	Accel/decel time is fixed at accel/decel time 2.

F117: UNDERTORQUE DETECTION

F118: UNDERTORQUE LEVEL

F119: UNDERTORQUE TIME

○ **Undertorque Detection**

An alarm signal can be output to a multi-function output terminal (MA-MB, P1 or P2) when the load on the machine suddenly becomes higher (i.e., when an undertorque occurs). To output an undertorque detection signal, set the output terminal function selection in F057, F058 or F059 to 8 (undertorque detected, a contact) or 9 (undertorque detected, b contact).

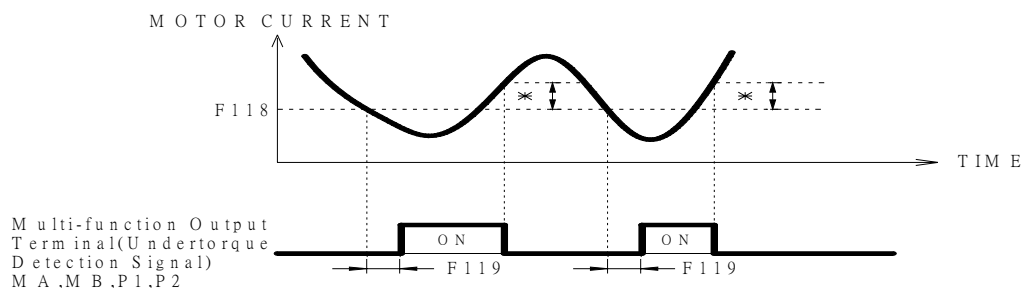

*Undertorque detection release width (hysteresis) is set at approx. 5% of the inverter's rated current.

Undertorque Detection Function Selection (F117)

Setting	Description
0	Undertorque detection not provided.
1	Detected during constant-speed running. Operation continues after detection.
2	Detected during constant-speed running. Operation stops.
3	Detected during running. Operation continues after detection.
4	Detected during running. Operation stops.

1. To detect undertorques during acceleration, set to 3 or 4.
2. To continue operation after undertorque detection, set to 1 or 3. During detection, the operation displays the “UL3” alarm (flashing).
3. To halt the inverter by a fault at undertorque detection, set to 2 or 4. At detection, the operation displays the “UL3” fault (continuously lit).

Undertorque Detection Level (F118)

Set the undertorque detection current level in units of 1% (Inverter rated current=100%). When detected by torque is selected, motor rated torque becomes 100%.

Factory setting=10%

Undertorque Detection Time (F119)

If the time for which the motor current is less than the undertorque detection level (F118) is longer than the undertorque detection time (F119), the undertorque detection function operates.

Factory setting: 0.1s.

F120: FREQUENCY REFERENCE 9
F121: FREQUENCY REFERENCE 10
F122: FREQUENCY REFERENCE 11
F123: FREQUENCY REFERENCE 12
F124: FREQUENCY REFERENCE 13
F125: FREQUENCY REFERENCE 14
F126: FREQUENCY REFERENCE 15
F127: FREQUENCY REFERENCE 16

Please refer to page 52.

F128: PID CONTROL SELECTION

■ Using PID Control Mode

For details of the PID control setting, refer to the block diagram of the inverter's internal PID control.

PID Control Selection (F128)

Setting	Description	PID output characteristics
0	Disabled.	—
1	Enabled: deviation is subject to differential control	Forward
2	Enabled: feedback signal is subject to differential control.	
3	Enabled: frequency reference + PID control and deviation are subject to differential control	
4	Enabled: frequency reference + PID control, and feedback signal are subject to differential control.	
5	Enabled: deviation is subject to differential control.	Reverse
6	Enabled: feedback signal is subject to differential control.	
7	Enabled: frequency reference + PID control, and deviation are subject to differential control.	
8	Enabled: frequency reference + PID control, and feedback signal are subject to differential control.	

Set one of the above values when using PID control, F128. The following table shows how to determine the target value and the feedback value to be input when the PID control is enabled.

	Input	Description
Target value	The currently selected frequency reference	Determined by the frequency reference selection (F004). When the local mode is selected, the target value is determined by frequency reference selection in local mode (F008) When the multi-step speed reference is selected, the currently selected frequency reference becomes the target value.
Feedback value	The frequency reference that is set to the PID feedback value selection (F164)	=0 Control circuit terminal FR (Voltage 0 ~10V) =1 Control circuit terminal FR (Current 4 ~ 20mA) =2 Control circuit terminal FR (Current 0 ~ 20mA) =3 Operator terminal CN2 (Voltage 0 ~ 10V) =4 Operator terminal CN2 (Current 4 ~ 20 mA) =5 Control circuit terminal PS pulse train input

- Notes:
1. When selecting frequency reference from the control circuit terminal FR as the target or feedback value, the switch of S1 on the control circuit board must be selected depending on the input method (current or voltage input).
 2. Never use the frequency reference from the control circuit terminal FR for both the target and feedback values.
 3. When using the analog signal(0 to 10V / 4 to 20mA) which inputs to the CN2 terminal of the digital operator RCU-550 as the target or feedback value of PID control, never use it as a multi-analog input. Constant F077 should be set to 0.

F129: PID FEEDBACK GAIN

PID feedback value adjusting Gain (F129)

Constant No.	Name	Unit	Setting range	Initial setting
F129	PID FEEDBACK GAIN	Multiples	0.00~10.00	1.00

F130: PROPORTION GAIN P

F131: INTEGRAL TIME I

F132: DERIVATIVE TIME D

Proportional gain (P), Integral time (I), Differential time (D) (F130, F131, F132)

Constant No.	Name	Unit	Setting range	Initial setting
F130	PROPORTIONAL GAIN (P)	Multiples	0.0 ~ 25.0	1.0
F131	INTEGRAL TIME (I)	Second	0 ~ 360.0	1.0
F132	DIFFERENTIAL TIME (D)	Second	0.00 ~ 2.50	0.00

Optimize the responsiveness by adjusting it while operating an actual load(mechanical system). Any control (P, I, or D) that is set to 0 will not operate.

F133: PID OFFSET ADJUSTMENT

PID offset adjustment (F133)

Constant No.	Name	Unit	Setting range	Initial setting
F133	PID OFFSET ADJUSTMENT	%	-100 ~100	0

If both the target value and the feedback values are set to 0, adjust F133 to 0.

F134: INTEGRAL (I) UPPER LIMIT

Integral (I) upper limit (F134)

Constant No.	Name	Unit	Setting Range	Initial Setting
F134	INTEGRAL (I) UPPER LIMIT	%	0 ~100	100

The constant prevents the calculated value of the integral control from exceeding the fixed amount. There is normally no need to change the setting. Redcue the setting if there is a risk of load damage, or of the motor going out of step by the inverter's response when the load suddenly changes.

F135: PID DELAY TIME

PID primary delay time constant (F135)

Constant No.	Name	Unit	Setting range	Initial setting
F135	PID DELAY TIME	second	0.0 ~ 100	0.0

Constant F135 is the low-pass filter setting for PID control outputs. If the viscous friction of the mechanical system is high or if the rigidity is low causing the mechanical system to resonate, increase the setting so that it is higher than resonance frequency period.

F136: PID FEEDBACK LOSS DETECTION
F137: PID FEEDBACK LOSS DETECTION LEVEL
F138: PID FEEDBACK LOSS DETECTION TIME

PID feedback loss detection (F136, F137, F138)

Constant No.	Name	Unit	Setting range	Initial setting
F136	PID FEEDBACK LOSS DETECTION	—	0: No detection of PID feedback loss 1: Operation continues after detection of PID feedback loss 2: Operation stops after detection of PID feedback loss	0
F137	PID FEEDBACK LOSS DETECTION LEVEL	%	100% (Max. output frequency)	0
F138	PID FEEDBACK LOSS DETECTION TIME	second	0.0~25.5	1.0

PID Limit: Sets the limit after PID control as a percentage of the maximum output frequency (100% / Max. output frequency)

Prohibition of PID Output: Zero limit occurs when the PID output is negative.

EI-550 PID Control Block Diagram

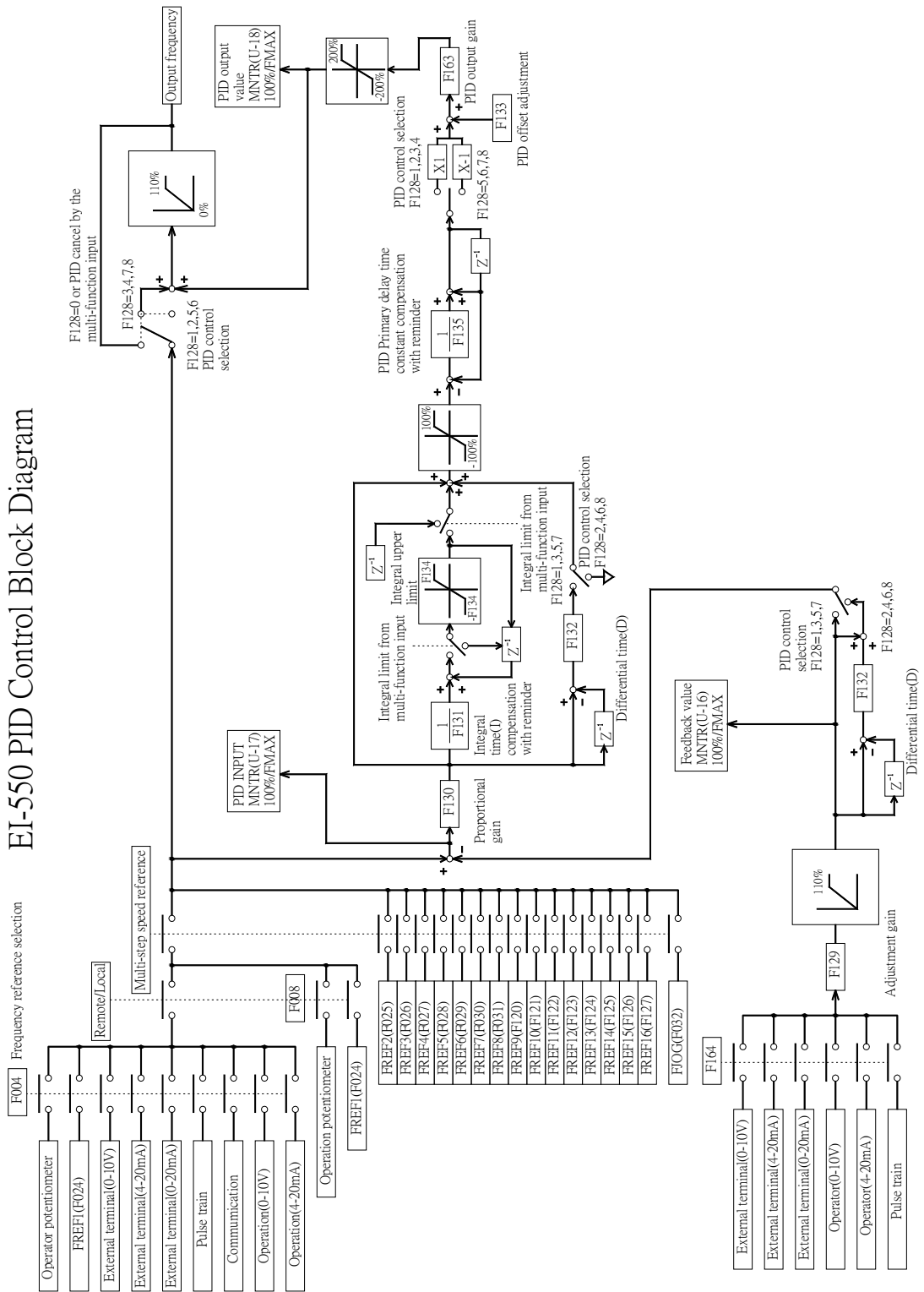

F139: ENERGY SAVE SELECTION

In V/F control mode, setting F139 to 1 enables the energy-saving control function.

F139 Setting value	0	1
Energy-saving control selection	Disabled	Enabled

F140: ENERGY SAVE K2
F158: ENERGY SAVE MOTOR CODE

Calculates the voltage for the best motor efficiency when operating in energy-saving control mode. The calculated voltage becomes the output voltage reference. The factory setting is set to the max. applicable motor capacity of a standard motor.

F140: The greater the energy-saving coefficient K2 is, the greater the output voltage becomes. Change the setting of the energy-saving coefficient K2 by 5% so that the output power becomes the smallest.

F158: When the motor code is set, the energy-saving coefficient K2 which corresponds to the motor code, is set to F140.

F141: ENERGY SAVE LOWER LMT@60HZ
F142: ENERGY SAVE LOWER LMT@6HZ
F159: ENERGY SAVE UPPER LIMIT@60HZ
F160: ENERGY SAVE UPPER LMT@6HZ**Energy-saving Voltage Lower / Upper Limit (F141, F142, F159, F160)**

Sets the upper and lower limits of the output voltage. When the value calculated in the energy-saving control mode is larger than the upper limit (or smaller than the lower limit), the value is output as a voltage reference value. The upper limit is set to prevent over-excitation, and the lower limit is set to prevent stalls when the load is light. The voltage limit is set for machines using 6Hz/60 Hz. For any voltage other than 6Hz/60Hz, set the (value of the) voltage limit according to linear interpolation. The value in 440V class is doubled.

Constant No.	Name	Unit	Setting range	Initial range
F141	ENERGY-SAVING CONTROL VOLTAGE LOWER LIMIT (60HZ)	%	0~120	50
F142	ENERGY-SAVING CONTROL VOLTAGE LOWER LIMIT (6HZ)	%	0~25	12
F159	UPPER VOLTAGE LIMIT FOR ENERGY-SAVING CONTROL (60HZ)	%	0~120	120
F160	UPPER VOLTAGE LIMIT FOR ENERGY-SAVING CONTROL (6HZ)	%	0~25	16

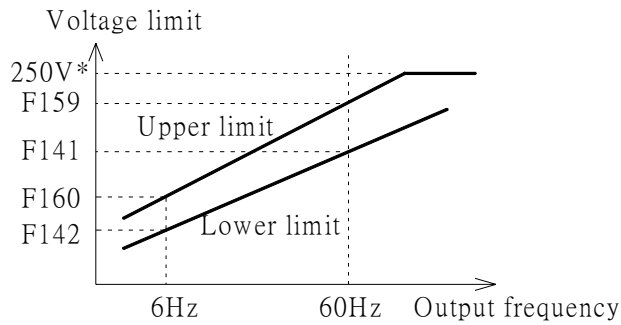

*Doubled for the 440V class inverters.

F143: POWER AVERAGE TIME
F144: SEARCH VOLTAGE LIMIT
F145: SEARCH VOLTAGE STEP @100%
F146: SEARCH VOLTAGE STEP @5%

○ **Energy-saving Search Operation**

In the energy-saving control mode, the max. applicable voltage is calculated using the output power. However, a temperature change or the use of another manufacturer's motor will change the fixed constants, and the max. applicable voltage may not be emitted. In the search operation, change the voltage slightly so that the max. applicable voltage can be obtained.

Search Operation Voltage Limit (F144)

Limits the range where the voltage can be controlled. The search operation is not performed when set to 0.

F144	Setting range	Unit	Initial setting	Description
SEARCH OPERATION VOLTAGE LIMIT	0~100	%	0	100% is voltage for 220V/440V

Search Operation Voltage Step

Constant No.	Name	Unit	Setting range	Initial setting
F145	SEARCH OPERATION VOLTAGE STEP (100%)	%	0.1~10.0	0.5
F146	SEARCH OPERATION VOLTAGE STEP (5%)	%	0.1~10.0	0.2
F143	POWER AVERAGE TIME	×24ms	1~200	1(24ms)

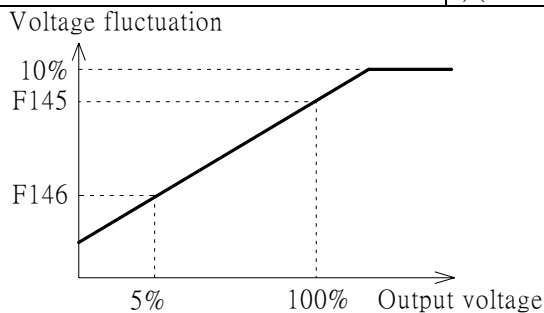

F149: PULSE TRAIN SCALING

Please refer to page 42.

F150: PULSE OUTPUT FREQUENCY

Pulse train signal can be selected by setting F150.

F150 Setting	Description	F150 Setting	Description
0 (Initial Setting)	1440Hz/Max. frequency(F011)	12	12F: Output frequency×12
1	1F: Output frequency×1	24	24F: Output frequency×24
6	6F: Output frequency×6	36	36F: Output frequency×36

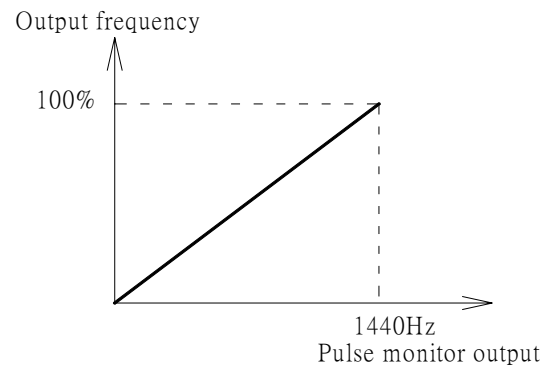
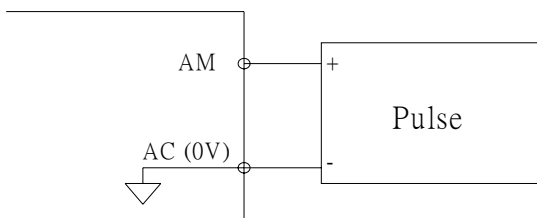

Used as a sourcing output

Output voltage VRL (V)	Load impedance (KΩ)
+5V	1.5KΩ or more
+8V	3.5KΩ or more
+10V	10KΩ or more

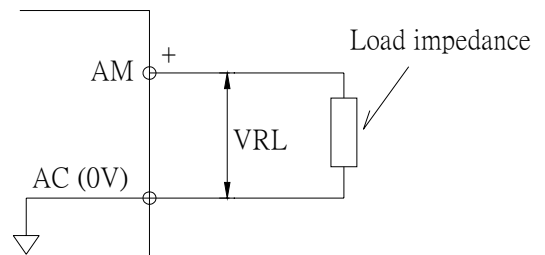

Used as a sinking input

External power supply (V)	+12V DC ±5%
Sinking current (mA)	16 mA or less

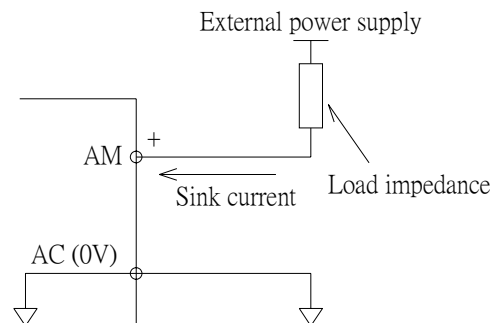

- F151: MODBUS TIMEOUT DETECTION**
- F152: MODBUS FREQUENCY UNIT**
- F153: MODBUS SLAVE ADDRESS**
- F154: MODBUS BAUD RATE**
- F155: MODBUS PARITY**
- F156: MODBUS SEND DELAY**
- F157: RTS CONTROL**

○ **MODBUS Communications**

MODBUS is composed of a single MASTER (PLC) and SLAVES (1 to 32 EI-550 units). Communication between MASTER and SLAVE (serial communication) is controlled according to the MASTER program with the MASTER initiating communication and the SLAVE responding.

The MASTER sends a signal to one SLAVE at a time. Each SLAVE has a preregistered address No., and the MASTER specifies the number and conduct signal communications. The SLAVE receives the communications to carry out designated functions and reply to the MASTER.

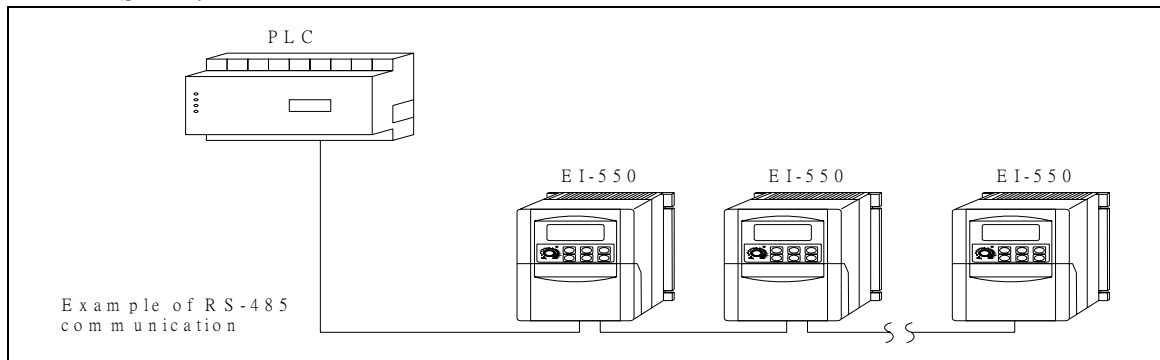

○ **Communications Connection Terminal**

Use the following S+, S-, R+ and R- terminals for MODBUS communications. Change the termination resistor as shown below.

RS-422 communications.....Turn ON S2 ON/OFF

RS-485 communications.....Turn ON S2 ON/OFF switch of only the inverter at termination viewed from the PLC.

Note:

1. Separate the wiring for communication from the main circuit wiring or other power lines.
2. Use shielded cables for communication wiring; connect the shielded sheath to the ground terminal.
3. When communication is performed through RS-485, connect S+ and R+, S- and R- terminals outside the inverter.

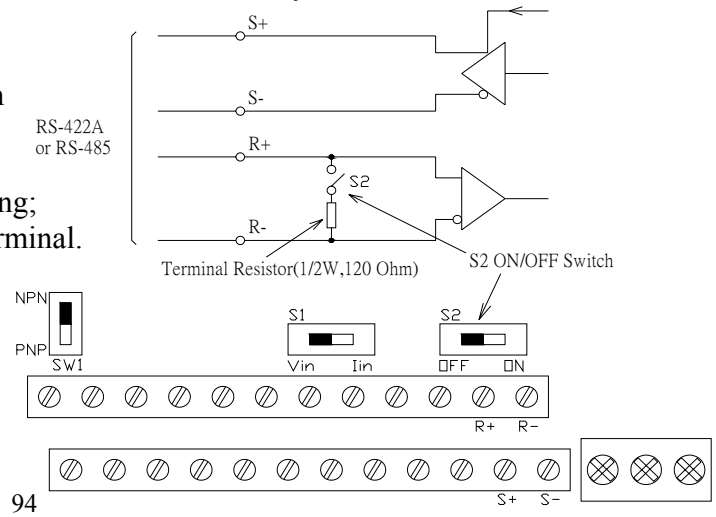

○ **Procedure for Communications with PLC**

1. Connect the communication cable between the PLC and the EI-550 with the power supply turned OFF.
2. Turn the power ON.
3. Set the constants (F151 to F157) required for communication by using the digital operator.
4. Turn the power OFF once to verify that the digital operator displays have been completely erased.
5. Turn the power ON again.
6. Communications with the PLC starts.

○ **Setting Constants Necessary for Communication**

Communication related constants must be set for PLC communication. Constants F152 to F157 cannot be set by communication. Always set them before performing communication.

Constant No.	Name	Description	Initial setting
F003	Run command selection	2 : MODBUS communication control	0
F004	Frequency reference selection	6 : MODBUS communication (Register No. 0002H)	0
F151	Timeover detection selection (Timeover: 2 sec.)	0 : Timeover detection (coast to a stop) 1 : Timeover detection (decelerates to a stop with speed reduction time 1) 2 : Timeover detection(decelerates to a stop with speed reduction time 2) 3 : Timeover detection(continuous operation, warning display) 4 : Timeover detection not provided	0
F152	MODBUS frequency reference and frequency monitor unit	0 : 0.1Hz 1 : 0.01Hz 2 : 30000/100%(30000=Max. output frequency) 3 : 0.1%	0
F153	MODBUS slave address	Setting range: 0 ~ 32 (0 : The slave does not respond to the command from the master when set to 0)	0
F154	MODBUS BPS selection	0 : 2400bps 1 : 4800bps 2 : 9600bps 3 : 19200bps	2
F155	MODBUS parity selection	0 : even parity 1 : odd parity 2 : no parity	0
F156	Transmission waiting time	Setting range : 10ms ~ 65ms Setting unit : 1ms	10ms
F157	RTS control	0 : RTS control 1 : No RTS control(RS-422A : 1 to 1 communication)	0

○ **Message Format**

Please refer to EI-550 INVERTER MODBUS RTU Instruction Manual for details of message format.

○ **Performing Self-test**

EI-550 is provided with a function to perform self-diagnosis for operation check of the serial communication I/F circuit. This function is called self-test. In the self-test, connect the sending terminal with the receiving terminal in the communication section. It assures if the data received by EI-550 is not being changed. It also checks if the data can be received normally.

Carry out the self-test in the following procedure.

1. Turn ON the EI-550 power supply. Set constant F056 to 35 (self-test).
2. Turn OFF the EI-550 power supply.
3. Make the following wiring with the power supply turned OFF.
4. Turn ON the EI-550 power supply.

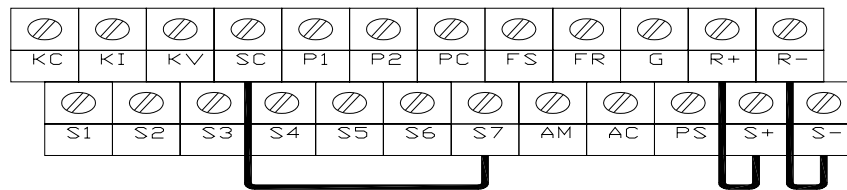

(Note: Select NPN side for SW 1)

Normal operation: Operator displays frequency reference value.

Faulty operation: Operator displays “CE” fault; signal is turned “ON” and inverter ready.
Signal is turned OFF

F158: ENERGY SAVE MOTOR CODE
F159: ENERGY SAVE UPPER LIMIT@60HZ
F160: ENERGY SAVE UPPER LIMIT@6HZ

Please refer F158, F159 and F160 to page 91.

F161: SEARCH POWER HOLD WIDTH

When the power fluctuation is less than F161 setting, the output voltage is held for 3 seconds. Then, the search operation mode is activated. Set the hold width F161 in % of the power which is currently held.

Constant No.	Name	Unit	Setting range	Initial setting
F161	SEARCH OPERATION POWER DETECTION HOLD WIDTH	%	0 ~ 100	10

F162: POWER DETECTION FILTER

Response at load change is improved when this value is small. However, at low frequency, unstable rotation will result.

Constant No.	Name	Unit	Setting range	Initial setting
F162	TIME CONSTANT OF POWER DETECTION FILTER	× 4ms	0 ~ 255	5(20ms)

F163: PID OUTPUT GAIN

Constant No.	Name	Unit	Setting range	Initial setting
F163	PID OUTPUT GAIN	Multiples	0.0 ~ 25.0	1.0

F164: PID FEEDBACK SELECT

Please refer to page 90.

F166: INPUT OPEN-PHASE LOSS LEVEL
F167: INPUT OPEN-PHASE LOSS TIME
F168: OUTPUT OPEN-PHASE LOSS LEVEL
F169: OUTPUT OPEN-PHASE LOSS TIME

■ Input/Output Open-phase Detection

Constant No.	Name	Unit	Setting range	Initial setting
F166	INPUT OPEN-PHASE DETECTION LEVEL	%	0 ~ 100%* ¹ 400.0V/100% (220V Class) 800.0V/100% (440V Class)	0%
F167	INPUT OPEN-PHASE DETECTION TIME	second	0 ~ 255s* ²	0s
F168	OUTPUT OPEN-PHASE DETECTION LEVEL	%	0 ~ 100%* ¹ Inverter's rated output current/100%	0%
F169	OUTPUT OPEN-PHASE DETECTION TIME	second	0.0 ~ 2.0s* ²	0.0s

*1 Not detected when set to 0%.

*2 Not detected when set to 0.0s.

The recommended settings for input open-phase detection are F166=7% and F167=10s.
(Open-phase cannot be detected correctly depending on the load status.)

The recommended settings for output open-phase detection are F168=5% and F169=0.2s.

F173: DC INJECTION PROPORTIONAL GAIN
F174: DC INJECTION INTEGRAL TIME

Constant No.	Name	Unit	Setting range	Initial setting
F173	DC INJECTION PROPORTIONAL GAIN	1=0.001	16 ~ 999	83 (0.083)
F174	DC INJECTION INTEGRAL TIME	1=4ms	1 ~ 250	25 (100ms)

F175: CARRIER@ LOW SPEED

Please refer to page 72.

F176: CONSTANT COPY SELECTION
F177: CONSTANT READ SELECTION

Using Constant Copy Function

○ **Constant Copy Function**

The EI-550 standard digital operator RCU-550 can store constants for one inverter. A backup power supply is not necessary since EEPROM is used.
Constant copy function is possible only for the inverters with same product series, (it is impossible to copy constants between EI-550 ↔ EI-500), same power supply specifications (220V class or 440 class), same motor capacity and same control mode (vector control or V/F control).

The prohibition of the digital operator RCU-550 reading of constants from the inverter can be set at F177=0, factory setting. The constant data cannot be changed when this constant is set.

Constant Copy Function Selection (F176)

Depending on the setting of F176 for constant copy function selection, the following functions are available:

- Read all the constants from the inverter (READ) and store them in EEPROM in the digital operator RCU-550.
- Copy the constants stored in the digital operator to the inverter (COPY).
- Verify that the constants in the digital operator and the constants in the inverter are the same (VERIFY).
- Display the software number, the maximum applicable motor capacity and the voltage class of the inverter that has the constants stored in the digital operator.

Constant No.	Name	Unit	Setting range	Initial setting
F176	CONSTANT COPY FUNCTION SELECTION	—	Rdy: READY rEd: READ CPy: COPY vFy: VERIFY vA: Inverter capacity display Sno: Software No. display	rdy

Prohibiting Constant Read Selection (F177)

Selects this function to prevent accidentally overwriting the constants stored in EEPROM or in the digital operator RCU-550. Reading is not possible when F177 is set to 0. The constant data stored in the digital operator are safe from accidental overwriting. When reading is performed

while F177 is set to 0, “PrE” will blink. Press  or  and return to constant No. display.

Constant No.	Name	Unit	Setting range	Initial setting
F177	CONSTANT READ SELECTION PROHIBIT	1	0: READ prohibited 1: READ allowed	0

○ READ Function (READ)



Reads out the constants in batch from the inverter and stores them in EEPROM inside the digital operator RCU-550. When the read-out is executed, the previously stored constants data in the EEPROM are cleared and replaced with the newly entered constants.

1. F001=4; Enable the setting of F001 to F170 for reading and writing.
2. F177=1; Allow the read-out and write-in of digital operator.
3. F176= “Constants read-out”; store constants from the inverter in EEPROM inside the digital operator.
4. F177=0; Prohibit digital operator read-out.

○ COPY Function (COPY)

Writes the constants stored inside the digital operator in batch to inverter. Write-in is possible only for the inverters with same product series, power supply specifications and control mode (V/F control or vector control). If it is different specification or different control mode, the digital operator will display “CPE”.

When satisfying the above condition, “VAE” will appear when the capacity of inverters

differs. Press  to continue COPY function and press  to stop COPY function.

Following constants are not written if the inverter capacity is different.

Constant No.	Name	Constant No.	Name
F011 ~ F017	V/F SETTING	F108	MOTOR LEAKAGE INDUCTANCE
F036	MOTOR RATED CURRENT	F109	TORQUE COMPENSATION VOLTAGE LIMITER
F080	CARRIER FREQUENCY REFERENCE	F110	MOTOR NO-LOAD CURRENT
F105	TORQUE COMPENSATION IRON LOSS	F140	ENERGY-SAVING COEFFICIENT K2
F106	MOTOR RATED SLIP	F158	MOTOR CODE
F107	LINE TO NEUTRAL (PER PHASE)		

“Write-in” Function Steps:

1. F001=4;
2. F176= “ Constants Write-in”



A setting range check and matching check for the written-in constants are executed after the constants are written from the digital operator to the inverter. If any constant error is found, the written constants are discarded and the constants stored before writing are restored.

○ **VERIFY Function (VERIFY)**

Collates the constants stored in the digital operator RCU-550 with the constants in the inverter. As well as write-in, VERIFY is possible only for the inverters with same product series, power supply specifications and control mode (V/Fcontrol or vector control). When the constants stored in the digital operator correspond to those in the inverter, “End” is displayed. If they do not respond, an unmatched constant No. or a constant value is displayed.

“ VERIFY” Function Steps:

1. F001=4;
2. F176= “VERIFY”;
3. If the constants match, operator will show “ vFy”
4. If the constants do not match, operator will display “ unmatched constant No.”

- a. Press  to display “ constant value in the inverter”
- b. Then press  to display “constant value in the digital operator”
- c. Then press  to continue to display the next “unmatched constant No.”
- d. Finally, display “ vFy” and it is done.

CHAPTER 5 MAINTENANCE AND INSPECTION

■ Periodical Inspection

Periodically inspect the inverter as described in the following table to prevent accidents and to ensure high performance with high-reliability.

Items for Checks		
Location to Check	Check for	Solution
Terminals, unit mounting screws, etc.	Connection hardware is properly seated and securely tightened	Properly seated and tighten hardware.
Heatsink	Built up dust, dirt, and debris	Blow with dry compressed air: $39.2 \sim 58.8 \times 10^4 \text{Pa}$ (4 ~ 6 kg/cm^2) pressure.
Printed circuit board	Accumulation of conductive material or oil mist	Blow with dry compressed air: $39.2 \sim 58.8 \times 10^4 \text{Pa}$ (4 ~ 6 kg/cm^2) pressure. If dust or oil cannot be removed, replace the inverter unit.
Power elements and smoothing capacitor	Abnormal odor or discoloration	Replace the inverter unit.
Cooling fan	Abnormal noise or vibration Cumulative operation time exceeding 20,000 hours	Replace the cooling fan.

■ Part Replacement

Inverter's maintenance periods are noted below. Keep them as reference.

Part Replacement Guides

Part	Standard Replacement Period	Replacement Method
Cooling fan	2 ~ 3 years	Replace with new part.
Smoothing capacitor	5 years	Replace with new part.
Breaker relays	—	Determine need by inspection.
Fuses	10 years	Replace with new part.
Aluminum capacitors on PCBs	5 years	Replace with new board.

Usage conditions are as follows:

- Ambient temperature: Yearly average of 30°C
- Load factor: 80% max.
- Operating rate: 12 hours max. per day

CHAPTER 6 FAULT DIAGNOSIS

■ Protective and Diagnostic Functions

This section describes the alarm and fault displays, the fault conditions, and the corrective actions to be taken if the EI-550 malfunctions.

Inverter alarms are classified into alarm display and fault display.

Alarm display: When a minor fault occurs in the inverter, the Digital Operator flashes the display. In this case, the operation is continued, and restored automatically as soon as the cause is removed. Multi-function output can output the minor fault status to external devices.

Fault display: When a major fault occurs in the inverter, the protective functions operates, and the Digital Operator lights the display and shuts off the output to stop the inverter. The fault can be output as a fault output to the external devices by multi-function output.

To reset the fault, use  key of Digital Operator or cycle the power after taking the second corrective action.

* Selecting “always ON” mode at fan operation selection (F039=1), the power must be cycled to release the alarm display.

Alarm Display and Contents

Alarm Display	Inverter Status	Explanation	Causes and Corrective Actions
Digital Operator			
Uu1 (Blinking)	Warning Fault contacts do not change state.	UV (Main circuit low voltage) Main circuit DC voltage drops below the low-voltage detection level while the inverter output is OFF. 220V:Main circuit DC voltage drops below approx. 200V. (160V for single phase) 440V:Main circuit DC voltage drops below approx. 400V.	Check the following : 1. Power supply voltage 2. Main circuit power supply wiring is connected. 3. Terminal screws are securely tightened.
ou (Blinking)		OV (Main circuit overvoltage) Main circuit DC voltage exceeds the overvoltage detection level while the inverter output is OFF. 220V class : approx. 410V or more 440V class : approx. 820V or more	Check the power supply voltage.

Alarm Display	Inverter Status	Explanation	Causes and Corrective Actions
Digital Operator			
oH (Blinking)	Warning Fault contacts do not change state.	OH (Cooling fin overheat) Intake air temperature rises while the inverter output is OFF.	Check the intake air temperature.
CAL (Blinking)		CAL (MODBUS communications waiting) F003 is 2 or F004 is 6, and power is turned ON.	Check communication devices, and transmission signals.
FbL (Blinking)		FBL (PID feedback loss detection) PID feedback value drops below the detection level F137 and longer than feedback loss detection time F138. When PID feedback loss is detected, the inverter operates according to F136 setting.	Check the mechanical system and correct the cause, or increase the value of F138.
bU5 (Blinking)		Option card communications fault. Communication fault has occurred in a mode that run command and frequency reference are set from the communication option card.	Check the communication devices or communication signals.
oP0 (Blinking)		(Constant setting error when the constant setting is performed through the MODBUS communication)	Check the setting values.
oP1 (Blinking)		Two or more values are set for multifunction input selection. Constants F050~F056	
oP2 (Blinking)		Relationship among V/F constants is not correct. Constants F011~F016	
oP3 (Blinking)		Setting value of motor rated current exceeds 150% of inverter rated current. Constant F036	

Alarm Display	Inverter Status	Explanation	Causes and Corrective Actions
Digital Operator			
oP4 (Blinking)	Warning Fault contacts do not change state.	Upper / lower limit of frequency reference is reversed. Constants F033 to F034	Check the setting values.
oP5 (Blinking)		Incorrect setting value of jump frequency reference. Constants F083 to F085	
oL3 (Blinking)		OL 3 (Overtorque detection) Motor current exceeds the preset value in constant F098.	Reduce the load, and expand the accel / decel time.
SEr (Blinking)		SER (Sequence error) Inverter receives LOCAL / REMOTE select command or communication / control circuit terminal changing signals from the multifunction terminal while the inverter is outputting.	Check the external circuit (sequence).
bb (Blinking)		BB (External baseblock) Baseblock command at multi-function terminal is active, the inverter output is shut OFF (motor coasting). Temporary condition is cleared when input command is removed.	Check the external circuit (sequence).
EF (Blinking)		EF (Simultaneous FWD/REV run commands) When FWD and REV run commands are simultaneously input for over 500ms, the inverter stops according to constant F005.	Check the external circuit (sequence).

Alarm Display	Inverter Status	Explanation	Causes and Corrective Actions
Digital Operator			
STP (Blinking)	Warning Fault contacts do not change state.	STP (Operator function stop) STOP/RESET key is pressed during running by the control circuit terminals FWD / REV command, or by the run command from communications. Inverter stops according to constant F005.	Open FWD/REV command of control circuit terminals .
		STP(Emergency stop) Inverter receives emergency stop alarm signal. Inverter stops according to constant F005.	Check the external circuit (sequence).
FAn (Blinking)		FAN(Cooling fan fault) Cooling fan is locked.	Check the cooling fan and if the cooling fan wiring is not connected.
CE (Blinking)		CE (MODBUS) communications fault	Check the communication devices or communication signals.
UL3 (Blinking)		UL3 (Undertorque detection) In V/ control mode: output current of inverter is lower than undertorque detection level (F118 setting value) In vector mode: Output current or output torque of inverter is lower than the detection level of F097 or F118. The undertorque is detected according to constant F117.	Checking the setting value of F118. Check the operation status and remove the cause.
oH3 (Blinking)	OH3(Inverter overheat) Multifunction input terminal (S1~S7) receives a fault signal, the inverter display overheat alarm.	Check the terminal signal of S1~S7. Check the wiring. Check the overheat signal.	

Fault Display and Contents

Fault Display Digital Operator	Inverter Status	Explanation	Causes and Corrective Actions
oC		OC (Overcurrent) Inverter output current momentarily exceeds approx. 250% of rated current.	Short circuit or grounding at inverter output side. Excessive load GD ² . Extremely rapid accel/ decel time. constants F019 to F022 Special motor used. Starting motor during coasting. Motor of a capacity greater than the inverter rating has been started. Magnetic contactor open/closed at the inverter output side.
ou	Protective Operation Output is shut OFF and motor coasts to a stop.	OV (Main circuit overvoltage) Main circuit DC voltage exceeds the overvoltage detection level because of excessive regenerative energy from the motor. 220V: Stops at main circuit DC voltage below approx. 410V. 440V: Stops at main circuit DC voltage approx. 820V	Insufficient decel time. (constants F020 and F022) Lowering of minus load. Increase decel time. Connect optional braking resistor.
Uu		UV1 (Main circuit low voltage) Main circuit DC voltage drops below the low-voltage detection level while the inverter output is ON. 220V: Stops at main circuit DC voltage below approx. 200V(160V for single-phase) 440V: Stops at main circuit DC voltage approx. 400V	Reduction of input power supply voltage. Open phase of input supply. Occurrence of momentary power loss. Check the power supply voltage, wiring and screws.
Uv2		UV2 (Control power supply fault) Voltage fault of control power supply is detected.	Cycle power. If the fault remains, replace the inverter.

Fault Display	Inverter Status	Explanation	Causes and Corrective Actions
Digital Operator			
oH	Protective Operation	OH (Cooling fin overheat) Temperature rise because of inverter overload operation or intake air temperature rise.	Excessive load. Improper V/F pattern setting. Insufficient accel time if the fault occurs during acceleration. Intake air temperature exceeding 50°C. Cooling fan stops. Check the load size, V/F pattern setting, intake air temperature.
oL1		OL1 (Motor overload) Motor overload protection operates by built-in electronic thermal overload relay.	Check the load size or V/F pattern setting. Set the motor rated current shown on the nameplate by constant F036.
oL2		OL2 (Inverter overload) Inverter overload protection operates by built-in electronic thermal overload relay.	Check the load size or V/F pattern setting. Check the inverter capacity.
oL3		OL3 (Overtorque detection) V/F mode: Inverter output current exceeds the preset value in constant F098. Vector mode: Motor current or torque exceeds the preset value in constants F097 and F098. When overtorque is detected, inverter performs operation according to the constant F096.	Check the driven machine and correct the cause of the fault, or increase the value of constant F098 up to the highest value allowed for the machine.
EF0		EF0: External fault reference through MODBUS communications.	Check the external circuit (sequence).
EF1		EF1: External fault input command from control circuit terminal S1	

Fault Display	Inverter Status	Explanation	Causes and Corrective Actions
Digital Operator			
EF2	Protective Operation	EF2: External fault input command from control circuit terminal S2	Check the external circuit (sequence).
EF3		EF3: External fault input command from control circuit terminal S3	
EF4		EF4: External fault input command from control circuit terminal S4	
EF5		EF5: External fault input command from control circuit terminal S5	
EF6		EF6: External fault input command from control circuit terminal S6	
EF7		EF7: External fault input command from control circuit terminal S7	
F00		Output is shut OFF and motor coasts to a stop.	
F01		CPF-01 Transmission fault occurred for 5 sec. or more when transmission starts with the digital operator.	Cycle power after checking the digital operator is securely mounted. If the fault remains, replace the digital operator or inverter.
F04		CPF-04 EEPROM fault of inverter control circuit is detected.	Record all constant data and initialize the constants. Cycle power. If the fault remains, replace the inverter.
F05		CPF-05 AD converter fault is detected.	Cycle power. If the fault remains, replace the inverter.
F06		CPF-06 Option card connecting fault. A non-corresponding option card is connected.	Check the option card. Cycle the power. If the fault remains, replace the option card.

Fault Display	Inverter Status	Explanation	Causes and Corrective Actions
Digital Operator			
F07	Protective Operation Output is shut OFF and motor coasts to a stop.	CPF-07 Operator control circuit (EEPROM or AD converter) fault.	Cycle power after checking the digital operator is securely mounted. If the fault remains, replace the digital operator or inverter.
F021		Communication option card self diagnostic error.	Option card fault Replace the option card.
F022		Communication option card model code error.	
F023		Communication option card DPRAM error.	
oPr		OPR (Operator connecting fault)	Cycle power. If the fault remains, replace the inverter.
CE		CE (MODBUS communications fault)	Check the communication devices or communication signals.
FbL	Stops according to constant F005	FbL (PID feedback loss detection) PID feedback value drops below the detection level F137 and longer than feedback loss detection time F138. When PID feedback loss is detected , the inverter operates according to F136 setting.	Check the mechanical system and correct the cause, or increase the value of F138.
bU5		Option card communications fault..	Check the communication devices or communication signals.
STP		STP (Emergency stop) Inverter receives emergency stop alarm signal. Inverter stops according to constant F005.	Check the external circuit (sequence).
— (OFF)		Insufficient power supply voltage Control power supply fault Hardware fault	Check power supply voltage, main circuit power, supply wiring, terminal screws, control sequence. If the fault remains, replace the inverter.